

User's manual FLIR Tools/Tools+

6.0

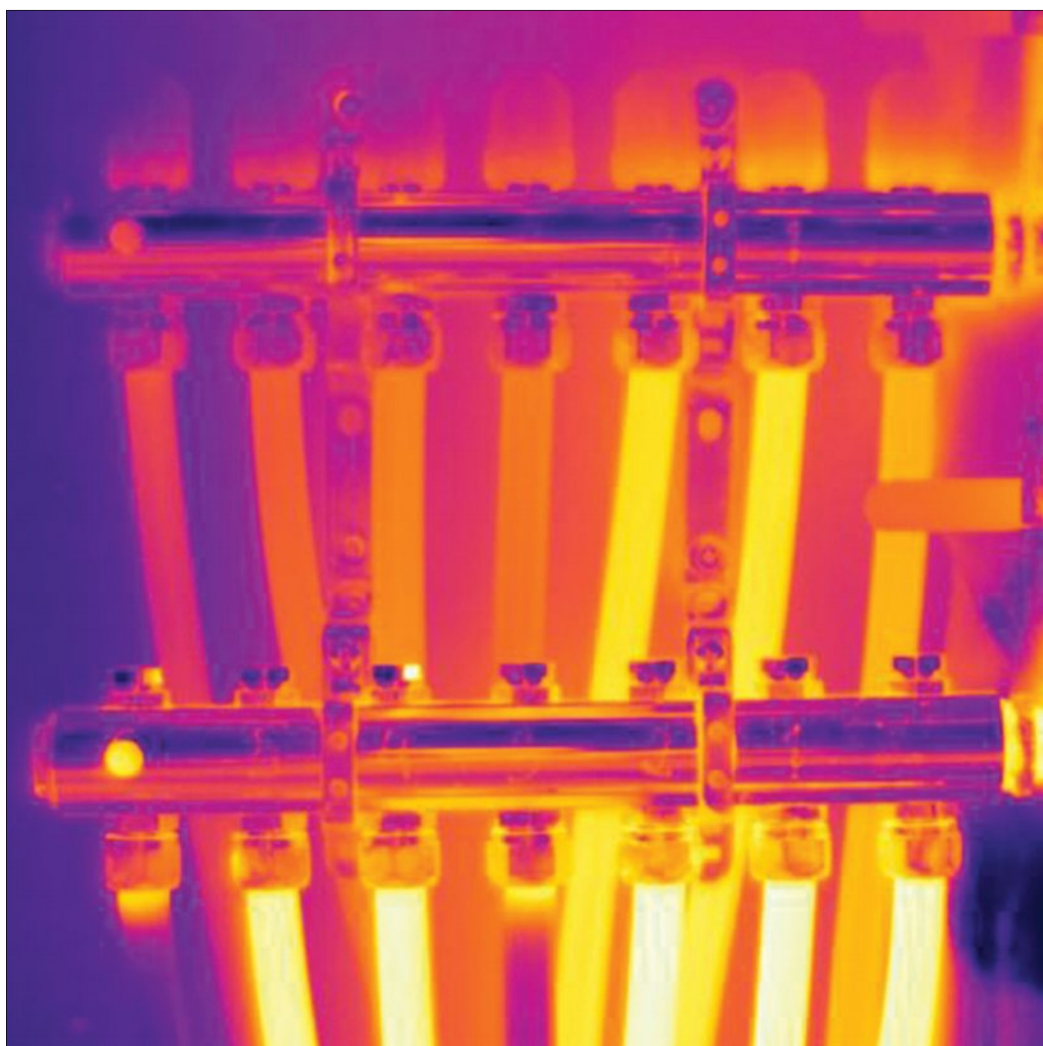



User's manual FLIR Tools/Tools+



Table of contents

1	Legal disclaimer	1
1.1	Legal disclaimer	1
1.2	Usage statistics	1
1.3	Changes to registry	1
1.4	Copyright	1
1.5	Quality assurance	2
2	Notice to user	3
2.1	User-to-user forums	3
2.2	Training	3
2.3	Documentation updates	3
2.4	Software updates	3
2.5	Important note about this manual	3
2.6	Additional license information	3
3	Customer help	4
3.1	General	4
3.2	Submitting a question	4
3.3	Downloads	5
4	Introduction	6
4.1	Comparison between FLIR Tools and FLIR Tools+	6
5	Installation	8
5.1	System requirements.....	8
5.1.1	Operating system	8
5.1.2	Hardware	8
5.2	Installation of FLIR Tools/Tools+	8
5.2.1	Procedure	8
6	Login	10
6.1	General	10
6.2	Login procedure	10
6.3	Logout.....	11
7	Enabling FLIR Tools+	13
8	Managing licenses	14
8.1	Activating your license	14
8.1.1	General.....	14
8.1.2	Figure.....	14
8.1.3	Activating FLIR Tools/Tools+ online	14
8.1.4	Activating FLIR Tools/Tools+ by e-mail	14
8.2	Activating FLIR Tools/Tools+ on a computer with no internet access	15
8.3	Transferring your license.....	16
8.3.1	General.....	16
8.3.2	Figure.....	17
8.3.3	Procedure	17
8.4	Activating additional software modules	17
8.4.1	General.....	17
8.4.2	Figure.....	18
8.4.3	Procedure	18
9	Workflow	19
9.1	General	19
9.2	Figure	19
9.3	Explanation	19
10	Importing images	20
10.1	Procedure	20
10.2	About UltraMax	21

Table of contents

11	Screen elements and toolbar buttons	22
11.1	Window elements: the <i>Library</i> tab	22
11.1.1	Figure	22
11.1.2	Explanation	22
11.2	Window elements: the <i>Instruments</i> tab	22
11.2.1	Figure	23
11.2.2	Explanation	23
11.3	Window elements: the <i>Create imagesheet</i> tab	24
11.3.1	Figure	24
11.3.2	Explanation	24
11.4	Window elements: the <i>Report</i> tab	25
11.4.1	Figure	25
11.4.2	Explanation	25
11.5	Window elements: the image-editing window (for still images)	26
11.5.1	Figure	26
11.5.2	Explanation	26
11.6	Window elements: the image-editing window (for video clips)	27
11.6.1	Figure	27
11.6.2	Explanation	27
11.7	Toolbar buttons (on the <i>Instruments</i> tab)	27
11.8	Toolbar buttons (in the image-editing window)	28
11.9	Toolbar buttons (in the report-editing window)	29
11.10	The <i>Panorama</i> tab	29
11.10.1	Figure	29
11.10.2	Explanation	29
12	Live image streaming of camera images	30
12.1	General	30
12.2	Figure	30
12.3	Procedure	30
13	Managing images and folders	32
13.1	Grouping files	32
13.1.1	General	32
13.1.2	Procedure	32
13.2	Saving a sequence file frame as a radiometric *.jpg file	32
13.2.1	General	32
13.2.2	Procedure	32
13.3	Saving a sequence file frame as an *.avi file	32
13.3.1	General	32
13.3.2	Procedure	32
13.4	Changing the playback speed	32
13.4.1	General	32
13.4.2	Procedure	33
13.5	Cloning images	33
13.5.1	General	33
13.5.2	Procedure	33
13.6	Extracting a digital camera photo from a multispectral image	33
13.6.1	General	33
13.6.2	Procedure: Extracting a photo	33
13.6.3	Procedure: Extracting a photo at its full field of view	33
13.7	Enhancing the resolution of an image	33
13.7.1	General	33
13.7.2	Indication of supported images	33
13.7.3	Procedure	34
13.8	Deleting images	34

Table of contents

	13.8.1 General.....	34
	13.8.2 Procedure	34
13.9	Adding a directory.....	34
	13.9.1 General.....	34
	13.9.2 Procedure	34
13.10	Deleting a directory	35
	13.10.1 General.....	35
	13.10.2 Procedure	35
13.11	Creating a subfolder	35
	13.11.1 General.....	35
	13.11.2 Procedure	35
14	Analyzing images	36
14.1	Laying out a measurement tool	36
	14.1.1 General.....	36
	14.1.2 Procedure	36
14.2	Moving a measurement tool	36
	14.2.1 General.....	36
	14.2.2 Procedure	36
14.3	Resizing a measurement tool	36
	14.3.1 General.....	36
	14.3.2 Procedure	36
14.4	Deleting a measurement tool	37
	14.4.1 General.....	37
	14.4.2 Procedure	37
14.5	Creating local markers for a measurement tool	37
	14.5.1 General.....	37
	14.5.2 Procedure	37
14.6	Setting local parameters for a measurement tool.....	38
	14.6.1 General.....	38
	14.6.2 Procedure	38
14.7	Working with isotherms	38
	14.7.1 General.....	38
	14.7.2 Setting up general isotherms (<i>Above, Below</i>).....	38
	14.7.3 Setting up general isotherms (Interval)	38
	14.7.4 Setting up a humidity isotherm	39
	14.7.5 Setting up an insulation isotherm	39
	14.7.6 Setting up a custom isotherm.....	40
14.8	Changing the temperature levels	41
	14.8.1 General.....	41
	14.8.2 Why change temperature levels?	41
	14.8.3 Changing the top level.....	41
	14.8.4 Changing the bottom level.....	42
	14.8.5 Changing both the top and bottom levels at the same time.....	42
14.9	Auto-adjusting an image.....	42
	14.9.1 General.....	42
	14.9.2 Procedure	42
14.10	Defining an auto-adjust region	42
	14.10.1 General.....	42
	14.10.2 Procedure	43
14.11	Changing the color distribution.....	43
	14.11.1 General.....	43
	14.11.2 Definitions	43
	14.11.3 Procedure	43
14.12	Changing the palette	43

Table of contents

14.12.1	General.....	43
14.12.2	Procedure	43
14.13	Changing the image mode.....	44
14.13.1	General.....	44
14.13.2	Types of image modes	44
14.14	Exporting to CSV	45
14.14.1	General.....	45
14.14.2	Procedure	45
14.15	Creating a plot.....	45
14.15.1	General.....	45
14.15.2	Procedure	45
14.16	Calculating areas.....	46
14.16.1	General.....	46
14.17	Calculating lengths.....	47
14.17.1	General.....	47
15	Working with annotations.....	48
15.1	About image descriptions	48
15.1.1	What is an image description?	48
15.2	About text annotations	48
15.2.1	What is a text annotation?	48
15.2.2	Definition of label and value	48
15.2.3	Example markup structure.....	49
15.2.4	Creating a text annotation for an image	49
15.2.5	Creating a text annotation template	49
16	Creating panoramas	51
16.1	General	51
16.2	Figure	51
16.3	Procedure	51
17	Creating reports.....	52
17.1	General	52
17.2	Setting a default report template.....	52
17.3	Saving a report in the intermediary *.repx format.....	53
17.4	Creating an Adobe PDF imagesheet	53
17.5	Creating an Adobe PDF report.....	53
17.6	Creating a radiometric Microsoft Word report	54
18	Working in the Microsoft Word environment	57
18.1	Managing objects in the report.....	57
18.1.1	<i>General</i>	57
18.1.2	Inserting a thermal image object	57
18.1.3	Inserting a digital photo object.....	57
18.1.4	Inserting a field object	58
18.1.5	Inserting a table object	59
18.1.6	Inserting a report properties object.....	65
18.1.7	Resizing objects.....	66
18.1.8	Replacing an image	67
18.1.9	Deleting objects	67
18.2	Editing an image.....	68
18.3	Working with formulas.....	68
18.3.1	General.....	68
18.3.2	Creating a simple formula	68
18.3.3	Creating a conditional formula.....	71
18.4	Document properties	74
18.4.1	General.....	74
18.4.2	Types of document properties	74

Table of contents

18.4.3	Creating and editing Microsoft Word document properties	74
18.5	Creating a report.....	74
18.6	Exporting a report	75
18.7	Creating a report template	75
18.8	Changing the settings	75
18.9	Help menu	76
19	Analyzing and editing images using the FLIR Report Studio Image Editor.....	77
19.1	General	77
19.2	Starting the Image Editor	77
19.2.1	Starting the Image Editor from the FLIR Word Add-in	77
19.2.2	Starting the Image Editor from the FLIR Report Studio wizard.....	77
19.3	Image Editor screen elements	78
19.3.1	Figure.....	78
19.3.2	Explanation.....	78
19.4	Basic image editing functions	79
19.4.1	Rotating the image	79
19.4.2	Cropping the image	79
19.5	Working with measurement tools.....	79
19.5.1	General.....	79
19.5.2	Adding a measurement tool.....	80
19.5.3	Moving and resizing a measurement tool.....	80
19.5.4	Creating local markers for a measurement tool	80
19.5.5	Calculating areas	80
19.5.6	Setting up a difference calculation.....	81
19.5.7	Deleting a measurement tool	82
19.6	Adjusting the infrared image.....	82
19.6.1	General.....	82
19.6.2	Example 1	82
19.6.3	Example 2	83
19.6.4	Changing the temperature levels	83
19.6.5	Auto-adjusting the image	84
19.6.6	Defining an auto-adjust region.....	84
19.7	Changing the color distribution.....	85
19.7.1	General.....	85
19.7.2	Definitions	85
19.7.3	Procedure	85
19.8	Changing the color palette	86
19.8.1	General.....	86
19.8.2	Procedure	87
19.9	Changing the image modes	88
19.9.1	General.....	88
19.9.2	Types of image modes	88
19.9.3	Procedure	89
19.10	Working with color alarms and isotherms	89
19.10.1	General.....	89
19.10.2	Image examples	90
19.10.3	Setting up above and below alarms	91
19.10.4	Setting up an interval alarm	91
19.10.5	Setting up a humidity alarm	92
19.10.6	Setting up an insulation alarm	92
19.10.7	Setting up a custom alarm.....	93
19.11	Changing the local parameters for a measurement tool	93
19.11.1	General.....	93

Table of contents

	19.11.2 Procedure	94
19.12	Working with annotations.....	94
	19.12.1 General.....	94
	19.12.2 About image descriptions.....	94
	19.12.3 About text annotations.....	95
20	Creating report templates.....	96
20.1	General	96
	20.1.1 Few or many report templates?	96
	20.1.2 Typical structure.....	96
	20.1.3 A note about working in the Microsoft Word environment.....	96
20.2	Creating a custom infrared report template	96
	20.2.1 Customizing a basic report template.....	97
	20.2.2 Modifying an existing template	97
	20.2.3 Adding multiple <i>DATA</i> sections.....	98
	20.2.4 Selecting a template category	99
21	Creating reports using the FLIR Report Studio wizard.....	101
21.1	General	101
21.2	Types of reports.....	101
21.3	Procedure	101
21.4	Saving a session	104
21.5	Changing the settings	105
22	Updating the camera and PC software	107
22.1	Updating the PC software	107
	22.1.1 General.....	107
	22.1.2 Procedure	107
22.2	Updating the camera firmware	107
	22.2.1 General.....	107
	22.2.2 Procedure	107
23	Changing settings	108
23.1	Settings relating to <i>Options</i> FLIR Tools/Tools+.....	108
	23.1.1 The <i>Options</i> dialog (for program-wide options)	108
	23.1.2 The <i>Options</i> dialog (for plot-specific options).....	110
23.2	Settings relating to FLIR Kx3 and FLIR Kx5 series cameras	111
	23.2.1 General.....	111
	23.2.2 The <i>General settings</i> tab.....	112
	23.2.3 The <i>User interface</i> tab	112
	23.2.4 Explanation of the different camera modes	114
23.3	Settings relating to FLIR Kx series cameras	116
	23.3.1 General.....	116
	23.3.2 The <i>General settings</i> tab.....	117
	23.3.3 The <i>User interface</i> tab	118
	23.3.4 Explanation of the different camera modes	119
24	Supported file formats	123
24.1	General	123
24.2	Radiometric file formats.....	123
24.3	Non-radiometric file formats	123
25	About FLIR Systems	124
25.1	More than just an infrared camera	125
25.2	Sharing our knowledge	125
25.3	Supporting our customers.....	126
26	Definitions and laws	127
27	Thermographic measurement techniques	129
27.1	Introduction	129

Table of contents

27.2	Emissivity.....	129
27.2.1	Finding the emissivity of a sample.....	129
27.3	Reflected apparent temperature.....	133
27.4	Distance	133
27.5	Relative humidity	133
27.6	Other parameters.....	133
28	History of infrared technology.....	134
29	Theory of thermography.....	137
29.1	Introduction	137
29.2	The electromagnetic spectrum.....	137
29.3	Blackbody radiation.....	137
29.3.1	Planck's law	138
29.3.2	Wien's displacement law.....	139
29.3.3	Stefan-Boltzmann's law	140
29.3.4	Non-blackbody emitters.....	141
29.4	Infrared semi-transparent materials.....	143
30	The measurement formula.....	144
31	Emissivity tables	148
31.1	References.....	148
31.2	Tables	148

1.1 Legal disclaimer

All products manufactured by FLIR Systems are warranted against defective materials and workmanship for a period of one (1) year from the delivery date of the original purchase, provided such products have been under normal storage, use and service, and in accordance with FLIR Systems instruction.

Products which are not manufactured by FLIR Systems but included in systems delivered by FLIR Systems to the original purchaser, carry the warranty, if any, of the particular supplier only. FLIR Systems has no responsibility whatsoever for such products.

The warranty extends only to the original purchaser and is not transferable. It is not applicable to any product which has been subjected to misuse, neglect, accident or abnormal conditions of operation. Expendable parts are excluded from the warranty.

In the case of a defect in a product covered by this warranty the product must not be further used in order to prevent additional damage. The purchaser shall promptly report any defect to FLIR Systems or this warranty will not apply.

FLIR Systems will, at its option, repair or replace any such defective product free of charge if, upon inspection, it proves to be defective in material or workmanship and provided that it is returned to FLIR Systems within the said one-year period.

FLIR Systems has no other obligation or liability for defects than those set forth above.

No other warranty is expressed or implied. FLIR Systems specifically disclaims the implied warranties of merchantability and fitness for a particular purpose.

FLIR Systems shall not be liable for any direct, indirect, special, incidental or consequential loss or damage, whether based on contract, tort or any other legal theory.

This warranty shall be governed by Swedish law.

Any dispute, controversy or claim arising out of or in connection with this warranty, shall be finally settled by arbitration in accordance with the Rules of the Arbitration Institute of the Stockholm Chamber of Commerce. The place of arbitration shall be Stockholm. The language to be used in the arbitral proceedings shall be English.

1.2 Usage statistics

FLIR Systems reserves the right to gather anonymous usage statistics to help maintain and improve the quality of our software and services.

1.3 Changes to registry

The registry entry HKEY_LOCAL_MACHINE\SYSTEM\CurrentControlSet\Control\Lsa\LmCompatibilityLevel will be automatically changed to level 2 if the FLIR Camera Monitor service detects a FLIR camera connected to the computer with a USB cable. The modification will only be executed if the camera device implements a remote network service that supports network logons.

1.4 Copyright

© 2016, FLIR Systems, Inc. All rights reserved worldwide. No parts of the software including source code may be reproduced, transmitted, transcribed or translated into any language or computer language in any form or by any means, electronic, magnetic, optical, manual or otherwise, without the prior written permission of FLIR Systems.

The documentation must not, in whole or part, be copied, photocopied, reproduced, translated or transmitted to any electronic medium or machine readable form without prior consent, in writing, from FLIR Systems.

Names and marks appearing on the products herein are either registered trademarks or trademarks of FLIR Systems and/or its subsidiaries. All other trademarks, trade names or company names referenced herein are used for identification only and are the property of their respective owners.

1.5 Quality assurance

The Quality Management System under which these products are developed and manufactured has been certified in accordance with the ISO 9001 standard.

FLIR Systems is committed to a policy of continuous development; therefore we reserve the right to make changes and improvements on any of the products without prior notice.

2.1 User-to-user forums

Exchange ideas, problems, and infrared solutions with fellow thermographers around the world in our user-to-user forums. To go to the forums, visit:

<http://forum.infraredtraining.com/>

2.2 Training

To read about infrared training, visit:

- <http://www.infraredtraining.com>
- <http://www.irtraining.com>
- <http://www.irtraining.eu>

2.3 Documentation updates

Our manuals are updated several times per year, and we also issue product-critical notifications of changes on a regular basis.

To access the latest manuals, translations of manuals, and notifications, go to the Download tab at:

<http://support.flir.com>

It only takes a few minutes to register online. In the download area you will also find the latest releases of manuals for our other products, as well as manuals for our historical and obsolete products.

2.4 Software updates

FLIR Systems regularly issues software updates and you can update the software using this update service. Depending on your software, this update service is located at one or both of the following locations:

- *Start > FLIR Systems > [Software] > Check for updates.*
- *Help > Check for updates.*

2.5 Important note about this manual

FLIR Systems issues generic manuals that cover several software variants within a software suite.

This means that this manual may contain descriptions and explanations that do not apply to your software variant.

2.6 Additional license information

For each purchased software license, the software may be installed, activated, and used on two devices, e.g., one laptop computer for on-site data acquisition, and one desktop computer for analysis in the office.

FLIR Customer Support Center

Home | Answers | Ask a Question | Product Registration | Downloads | My Stuff | Service

FLIR Customer support

Get the most out of your FLIR products

Get Support for Your FLIR Products

Welcome to the FLIR Customer Support Center. This portal will help you as a FLIR customer to get the most out of your FLIR products. The portal gives you access to:

- The FLIR Knowledgebase
- Ask our support team (requires registration)
- Software and documentation (requires registration)
- FLIR service contacts

Find Answers
We store all resolved problems in our solution database. Search by product, category, keywords, or phrases.

Search by Keyword

[Search All Answers](#)

[See All Popular Answers](#)

To find a datasheet for a current product, click on a picture.
To find a datasheet for a legacy product, click [here](#).

FLIR Ex



FLIR Exx



FLIR Kxx



FLIR T4xx



FLIR T6xx



FLIR G3xx



ThermaCAM™
GasFindIR



FLIR GF3xx



FLIR AX



FLIR Ax5



FLIR A3xx



[More...](#)

Product catalog
Please right-click the links below and select Save Target As... to save the file.



US Letter (28 Mb)
A4 (27.4 Mb)

Important legal disclaimer, dangers, warnings, and cautions

Accessories



3.1 General

For customer help, visit:

<http://support.flir.com>

3.2 Submitting a question

To submit a question to the customer help team, you must be a registered user. It only takes a few minutes to register online. If you only want to search the knowledgebase for existing questions and answers, you do not need to be a registered user.

When you want to submit a question, make sure that you have the following information to hand:

- The camera model
- The camera serial number
- The communication protocol, or method, between the camera and your device (for example, SD card reader, HDMI, Ethernet, USB, or FireWire)
- Device type (PC/Mac/iPhone/iPad/Android device, etc.)
- Version of any programs from FLIR Systems

- Full name, publication number, and revision number of the manual

3.3 Downloads

On the customer help site you can also download the following, when applicable for the product:

- Firmware updates for your infrared camera.
- Program updates for your PC/Mac software.
- Freeware and evaluation versions of PC/Mac software.
- User documentation for current, obsolete, and historical products.
- Mechanical drawings (in *.dxf and *.pdf format).
- Cad data models (in *.stp format).
- Application stories.
- Technical datasheets.
- Product catalogs.

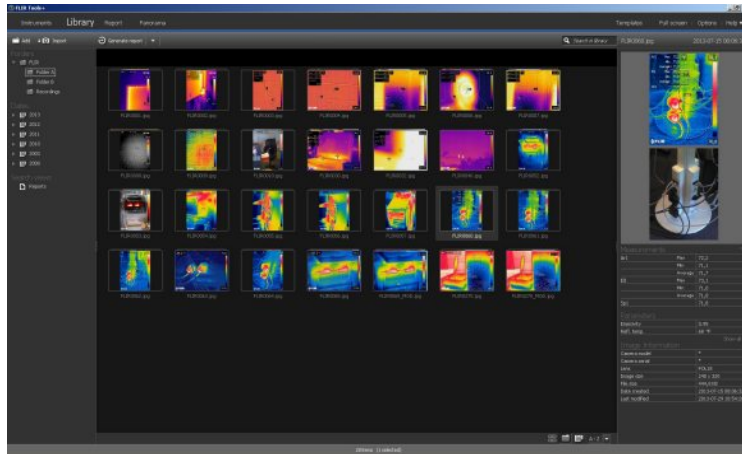

FLIR Tools/Tools+ is a software suite specifically designed to provide an easy way to update your camera and create inspection reports.

Examples of what you can do in FLIR Tools/Tools+ include the following:

- Import images from your camera to your computer.
- Apply filters when searching for images.
- Lay out, move, and resize measurement tools on any infrared image.
- Group and ungroup files.
- Create panoramas by stitching several smaller images into a larger one.
- Create PDF imagesheets of any images of your choice.
- Add headers, footers, and logos to imagesheets.
- Create PDF/Microsoft Word reports for images of your choice.
- Add headers, footers, and logos to reports.
- Update your camera with the latest firmware.

4.1 Comparison between FLIR Tools and FLIR Tools+

This table explains the difference between FLIR Tools and FLIR Tools+.

Feature/function	FLIR Tools	FLIR Tools+
Import images using USB.	X	X
Create infrared/digital photo image groups manually.	X	X
Measure temperatures using spots, areas, lines, and isotherms.	X	X
Measure a temperature difference.	X	X
Adjust object parameters.	X	X
View a live image.	X	X
Save infrared *.jpg files from a live image.	X	X
Record a video sequence (*.seq).		X
Record a video sequence (*.csq).		X
Replay a recorded sequence.	X	X
Export a recorded sequence to *.avi.	X	X
Create a temporal plot.	X	X
Export plot data to Microsoft Excel.	X	X
Export an image to *.csv format.	X	X

Feature/function	FLIR Tools	FLIR Tools+
Create a panorama image.		X
Create a PDF report.	X	X
Create a non-radiometric Microsoft Word report		X
Create a radiometric Microsoft Word report		X
Create text annotation templates for the camera.	X	X
Add/edit text annotations and image descriptions.	X	X
Listen to voice comments on infrared images.	X	X

Note

A new FLIR Word Add-in was introduced in FLIR Tools/Tools+ version 6.0. The FLIR Word Add-in adds a number of commands that are specific to the area of infrared imaging and reporting in the Microsoft Word environment. For legacy FLIR Word Add-in information, refer to the manual for FLIR Tools/Tools+ version 5.12 (publication number: T810199).

5.1 System requirements

5.1.1 Operating system

FLIR Tools/Tools+ supports USB 2.0 and 3.0 communication for the following PC operating systems:

- Microsoft Windows 7, 32 bit.
- Microsoft Windows 7, 64 bit.
- Microsoft Windows 8, 32 bit.
- Microsoft Windows 8, 64 bit.
- Microsoft Windows 10, 32 bit.
- Microsoft Windows 10, 64 bit.

5.1.2 Hardware

- Personal computer with a dual-core 2 GHz processor.
- 4 GB of RAM (minimum—8 GB recommended).
- 128 GB hard disk, with at least 15 GB of available hard disk space.
- DVD-ROM drive.
- Support for DirectX 9 graphics with:
 - WDDM driver
 - 128 MB of graphics memory (minimum)
 - Pixel Shader 2.0 in hardware
 - 32 bits per pixel.
- SVGA (1024 × 768) monitor (or higher resolution).
- Internet access (fees may apply).
- Audio output.
- Keyboard and mouse, or a compatible pointing device.

5.2 Installation of FLIR Tools/Tools+

Note

- If you have FLIR Tools/Tools+ with the legacy FLIR Word Add-in (version 5.12 or lower) installed, you must first uninstall this version of FLIR Tools/Tools+.
- Before you install FLIR Tools/Tools+, close all programs.

5.2.1 Procedure

Follow this procedure:

1. Double-click the installation file *FLIR Tools.exe*. This starts the installation wizard.

2. Select the *I agree to the license terms and conditions* and the *FLIR Report Studio* check boxes. Click *Install*. This starts the setup of FLIR Tools/Tools+.



3. When the setup is completed, click *Close*.

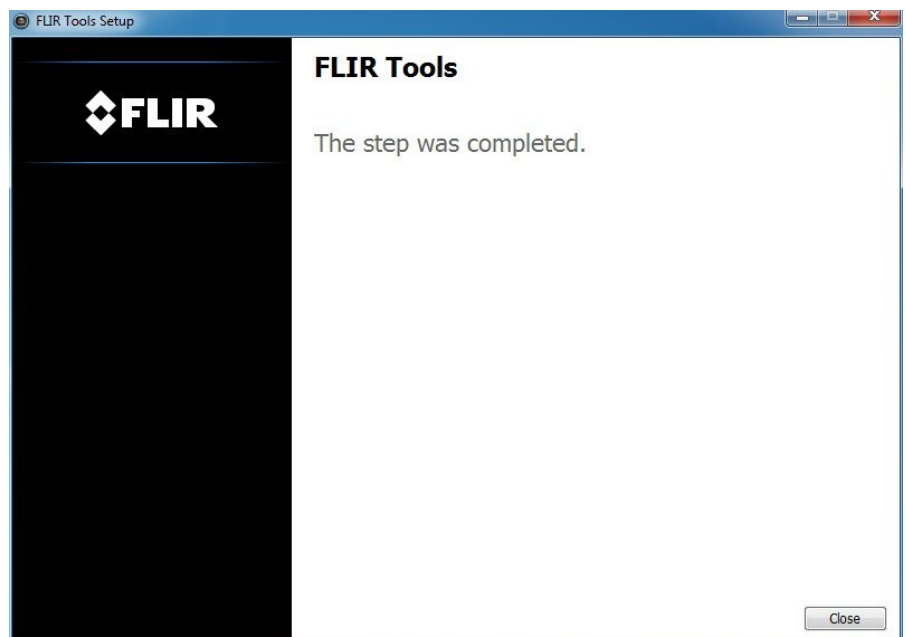

4. The installation is now complete. If you are asked to restart your computer, do so.

Follow this procedure:

1. Insert the FLIR Tools/Tools+ installation CD/DVD into the CD/DVD drive. The installation should start automatically.
2. In the *Autoplay* dialog box, click *Run setup.exe (Published by FLIR Systems)*.
3. In the *User Account Control* dialog box, confirm that you want to install FLIR Tools/Tools+.
4. In the *Ready to Install the Program* dialog box, click *Install*.
5. Click *Finish*. The installation is now complete. If you are asked to restart your computer, do so.

6.1 General

The first time you start FLIR Tools/Tools+, you must log in with a FLIR Customer Support account. If you already have an existing FLIR Customer Support account, you can use the same login credentials.

Note

- When you log in, your computer must have internet access.
- Unless you log out, you do not need to log in again to use FLIR Tools/Tools+.

6.2 Login procedure

Follow this procedure:

1. Start FLIR Tools/Tools+.
2. The *FLIR Login and Registration* window is displayed:

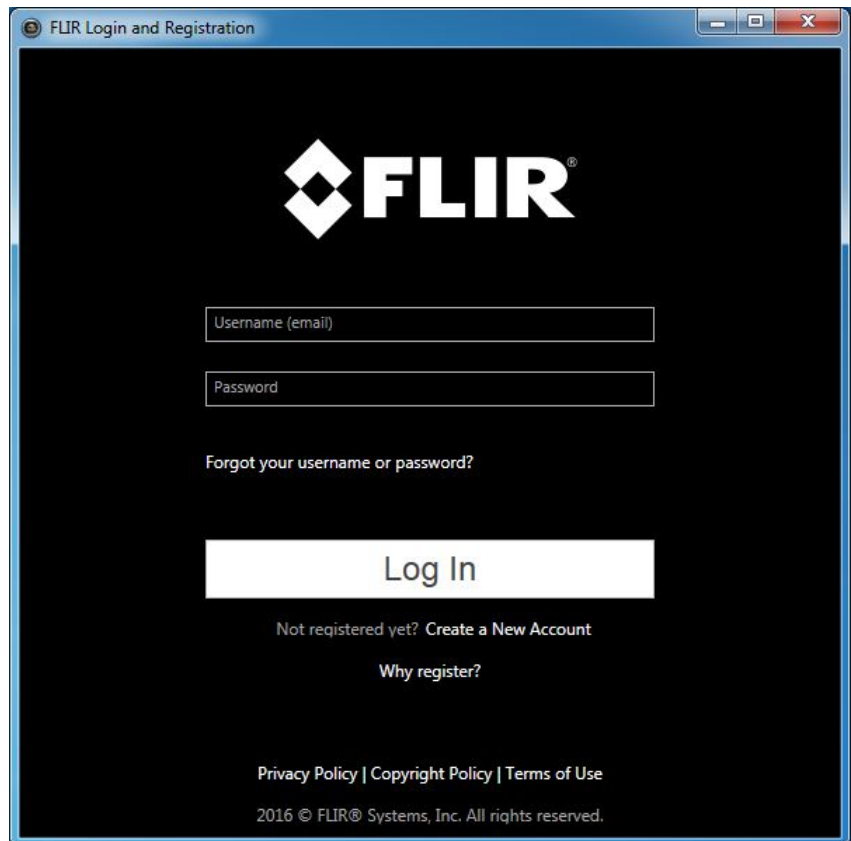

3. To log in with your existing FLIR Customer Support account, do the following:
 - 3.1. In the *FLIR Login and Registration* window, enter your username and password.
 - 3.2. Click *Log In*. Depending on the internet connection, it may take a few seconds for FLIR Tools/Tools+ to start.

4. To create a new FLIR Customer Support account, do the following:

- 4.1. In the *FLIR Login and Registration* window, click *Create a New Account*. This opens the *FLIR Customer Support Center* page in a web browser.
- 4.2. Enter the required information and click *Create Account*.

FLIR Customer Support Center

Home | Answers | Ask a Question | Product Registration | Downloads | My Stuff | Service

Create Account

* Denotes a required field.

—New Account—

Username (email) *

Password *

Must be at least 6 characters

Verify Password *

—Contact Information—

First Name *

Last Name *

Email Address *

Telephone

Company *

Address

City

State

Postal Code

Country *

—When You are Done...—

[Create Account](#)

- 4.3. In the *FLIR Login and Registration* window, enter your username and password.
- 4.4. Click *Log In*. Depending on the internet connection, it may take a few seconds for FLIR Tools/Tools+ to start.

6.3 Logout

Normally, there is no need to log out. If you log out, you need to log in again to start FLIR Tools/Tools+.

Follow this procedure:

1. In the upper menu bar, to the far right, click your username.

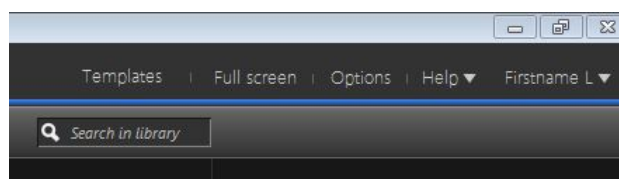

2. Click *Log Out*.

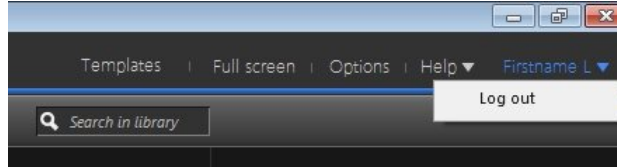

3. In the dialog box, do one of the following:

- To log out and exit FLIR Tools/Tools+, click *Yes*. This will close the application, and all of your unsaved work will be lost.
- To cancel and return to the application, click *Cancel*.

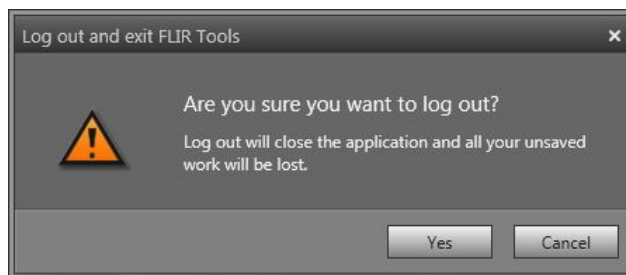

FLIR Tools+ adds a number of features to FLIR Tools, such as recording and play-back of radiometric video files, time–temperature plotting, Microsoft Word reporting, grouping of files, stitching of images into panoramas, and more.

To enable FLIR Tools+, follow this procedure:

1. On the *Help* menu, click *License options*.
2. For FLIR Tools+, click *Apply*.
3. Restart the program.

A 30-day evaluation version of FLIR Tools+ has now begun. If you want to use the program after 30 days, you need to purchase it.

For more information, see section 8.4 *Activating additional software modules*, page 17.

8.1 Activating your license

8.1.1 General

The first time you start FLIR Tools/Tools+ you will be able to choose one of the following options:

- Activate FLIR Tools/Tools+ online.
- Activate FLIR Tools/Tools+ by e-mail.
- Purchase FLIR Tools/Tools+ and receive a serial number for activation.
- Use FLIR Tools/Tools+ for free during an evaluation period.

8.1.2 Figure

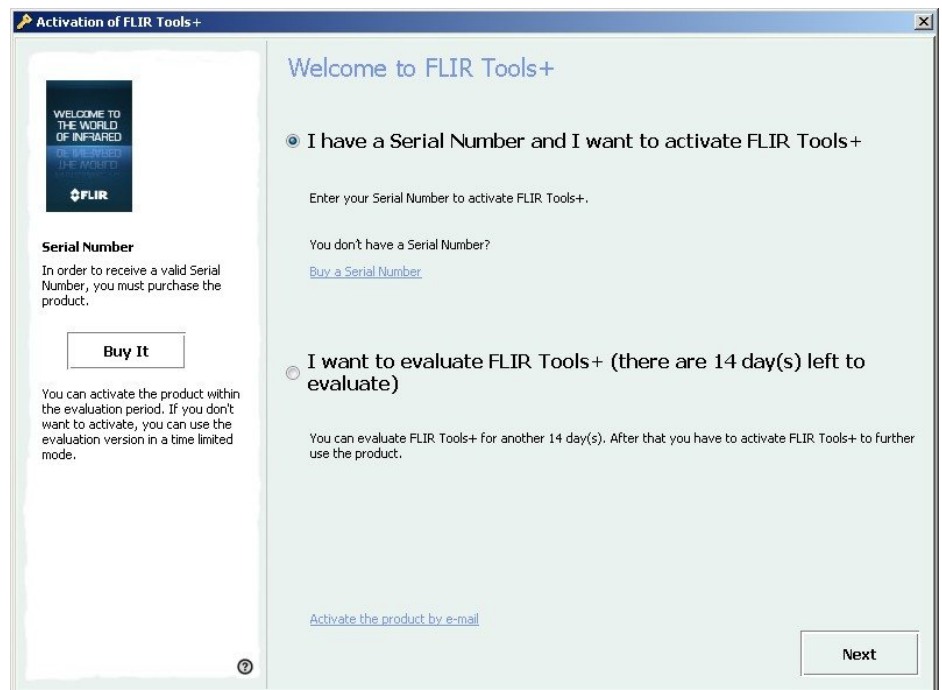

Figure 8.1 Activation dialog box.

8.1.3 Activating FLIR Tools/Tools+ online

Note Your computer needs to have internet access during this procedure.

Follow this procedure:

1. Start FLIR Tools/Tools+.
2. In the web activation dialog box, select *I have a Serial Number and I want to activate FLIR Tools/Tools+*.
3. Click *Next*.
4. Enter your serial number, name, company and e-mail address. The name should be that of the license holder.
5. Click *Next*.
6. Click *Activate now*. This will start the web activation process.
7. When the message *Online activation was successful* is displayed, click *Close*.
You have now successfully activated FLIR Tools/Tools+.

8.1.4 Activating FLIR Tools/Tools+ by e-mail

Note Your computer needs to have internet access during this procedure.

Follow this procedure:

1. Start FLIR Tools/Tools+.
2. In the web activation dialog box, click *Activate the product by e-mail*.
3. Enter your serial number, name, company and e-mail address. The name should be that of the license holder.
4. Click *Request Unlock Key by E-mail*.
5. Your default e-mail client now opens, and an unsent e-mail with the license information is displayed.

Note Send this e-mail without altering the content.

The main purpose of the e-mail is to send the license information to the activation center.

6. Click *Next*. The program will now start and you can continue working while waiting for the unlock key. You should receive an e-mail with the unlock key within 2 days.
7. When the e-mail with the unlock key arrives, start the program and enter the unlock key in the text box. See the figure below.

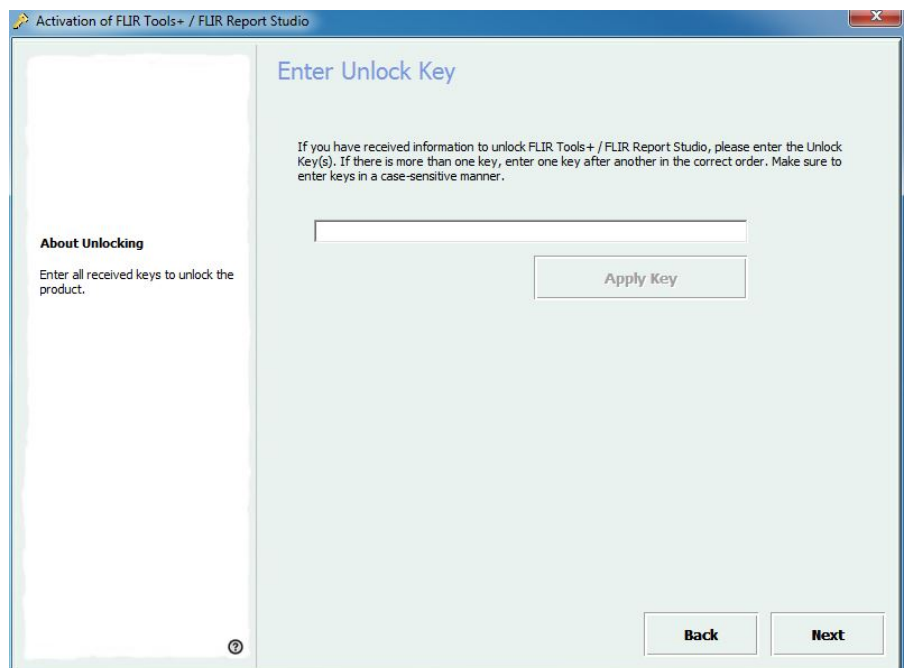

Figure 8.2 Unlock key dialog box.

8.2 Activating FLIR Tools/Tools+ on a computer with no internet access

If your computer does not have internet access, you can request the unlock key by e-mail from another computer.

Follow this procedure:

1. Start FLIR Tools/Tools+.
2. In the web activation dialog box, click *Activate the product by e-mail*.
3. Enter your serial number, name, company and e-mail address. The name should be that of the license holder.
4. Click *Request Unlock Key by E-mail*.
5. Your default e-mail client now opens, and an unsent e-mail with the license information is displayed.

Note If there is no e-mail client on the computer, you will be prompted to configure an e-mail client.

6. Copy the e-mail, without altering the content, to e.g. an USB stick and send the e-mail to *activate@flir.se* from another computer.
The main purpose of the e-mail is to send the license information to the activation center.
7. Click *Next*. The program will now start and you can continue working while waiting for the unlock key. You should receive an e-mail with the unlock key within 2 days.
8. When the e-mail with the unlock key arrives, start the program and enter the unlock key in the text box. See the figure below.

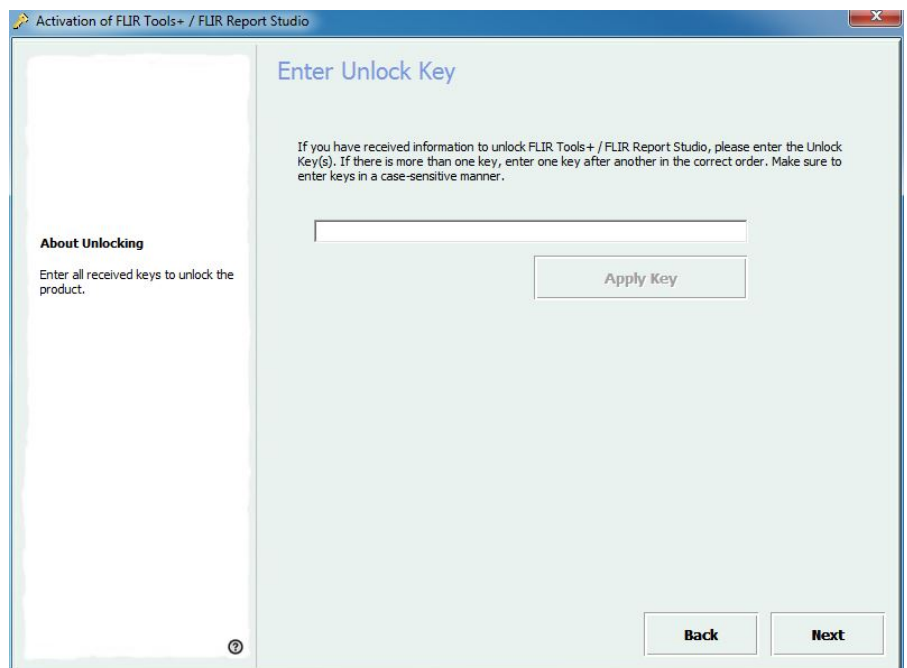

Figure 8.3 Unlock key dialog box.

8.3 Transferring your license

8.3.1 General

You can transfer a license from one computer to another computer, as long as you do not exceed the number of purchased licenses.

This lets you use the software on, for example, a desktop PC and a laptop computer.

8.3.2 Figure

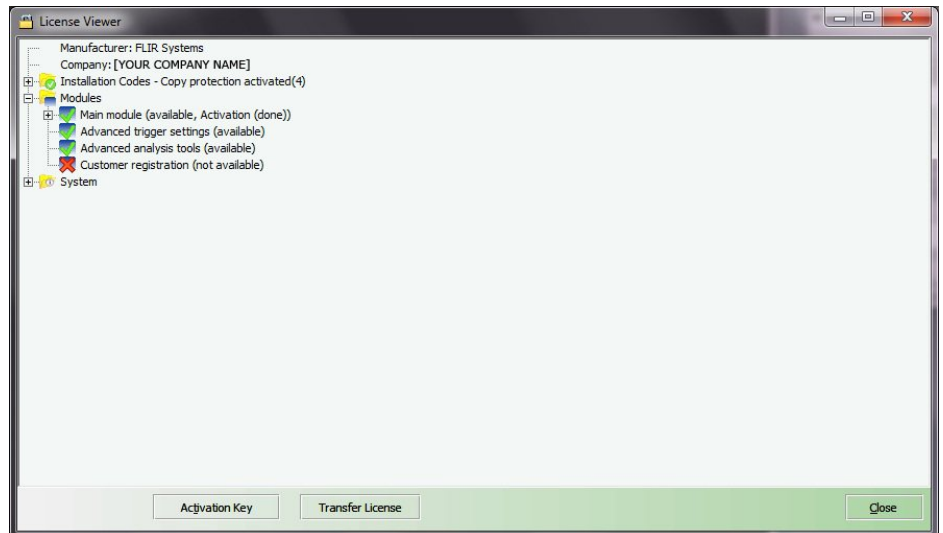

Figure 8.4 License viewer (example image only).

8.3.3 Procedure

Note Your computer needs to have internet access during this procedure.

Follow this procedure:

1. Start FLIR Tools/Tools+.
2. On the *Help* menu, select *Show license information*. This will display the license viewer shown above.
3. In the license viewer, click *Transfer license*. This will display a deactivation dialog box.
4. In the deactivation dialog box, click *Deactivate*.
5. On the computer to which you want to transfer the license, start FLIR Tools/Tools+. As soon as the computer has internet access, the license will be automatically adopted.

Note The adoption of licenses is based on a “first-come, first-serve” concept. This means that the *first* computer that gets internet access automatically adopts the transferred license.

8.4 Activating additional software modules

8.4.1 General

For some software, you can purchase additional modules from FLIR Systems. Before you can use the module, you need to activate it.

8.4.2 Figure



Figure 8.5 License viewer, showing available software modules (example image only).

8.4.3 Procedure

Note Your computer needs to have internet access during this procedure.

Follow this procedure:

1. Download and install the software module. Software modules are typically delivered as printed scratchcards with a download link.
 2. Start FLIR Tools/Tools+.
 3. On the *Help* menu, select *Show license information*. This will display the license viewer shown above.
 4. Select the module that you have purchased.
 5. Click *Activation Key*.
 6. On the scratchcard, scratch the field to see the activation key.
 7. Enter the key into the *Activation Key* text box.
 8. Click OK.
- The software module has now been activated.

9.1 General

When you carry out an infrared inspection you follow a typical workflow. This section gives an example of an infrared inspection workflow.

9.2 Figure



9.3 Explanation

1. Use your camera to take your infrared images and/or digital photos.
2. Connect your camera to a PC using a USB connector.
3. Import the images from the camera into FLIR Tools/Tools+.
4. Do one of the following:
 - Create a PDF imagesheet in FLIR Tools.
 - Create a PDF report in FLIR Tools.
 - Create a non-radiometric Microsoft Word report in FLIR Tools+.
 - Create a radiometric Microsoft Word report in FLIR Tools+.
5. Send the report to your client as an attachment to an e-mail.

10.1 Procedure

Follow this procedure:

1. Install FLIR Tools/Tools+ on your computer.
2. Start FLIR Tools/Tools+.
3. Turn on the camera.
4. Connect the camera to the computer, using a USB cable. This displays a dialog box.

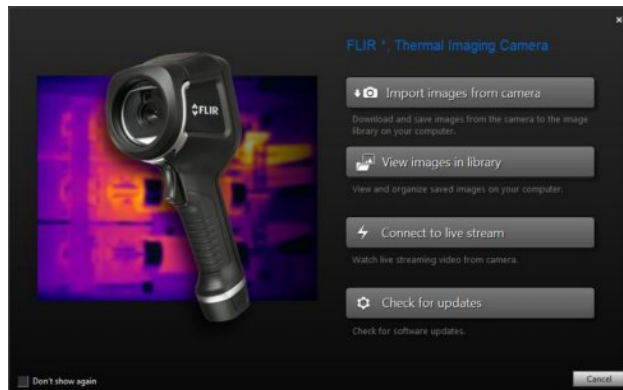

Figure 10.1 Import guide (example).

Note For some older camera models, you need to set the USB mode to *mass storage device* (MSD) or *mass storage device—UVC* (MSD-UVC).

5. Click *Import images from camera*. This displays a dialog box where you can see the images in the camera. For cameras with more than one folder, you can select the folders in the left pane.
6. In the right pane, select one or more of the check boxes:
 - *Hide already imported items*.
 - *Delete items from device after import*.
 - *Enhance image resolution* (UltraMax, see below).
 - *Backup original images before enhancement*.
7. Applicable to cameras with more than one folder. Do one of the following:
 - To import all images in all folders, click *Import all folders* at the bottom left.
 - To import all images in multiple folders, use the **Ctrl** key + click to select the folders. Then click *Import folders* at the bottom right.
 - To import all images in one folder, select the folder and then click *Import folder* at the bottom right.
 - To import selected images in one folder, select the folder and use the **Ctrl** key + click to select the images. Then click *Import items* at the bottom right.
8. Applicable to cameras with one folder. Do one of the following:
 - To import all images, click *Import all* at the bottom left.
 - To import selected images, use the **Ctrl** key + click to select the images. Then click *Import items* at the bottom right.
9. The *Select destination* dialog box is displayed. Select the destination folder or create a new subfolder.
10. Click *Import*. This starts the import of the images.

Note

- When the images are imported, all file associations will be kept. For example, if a digital photo is grouped together with an infrared image in the camera, this association will be retained in FLIR Tools/Tools+. The same applies for text annotations, voice annotations, sketches, etc.
- When images are imported from a camera with more than one folder, the camera folder structure will be retained in the destination folder on the computer.

10.2 About UltraMax

UltraMax is an image enhancement feature that will increase the image resolution and lower the noise, making small objects easier to see and measure. An UltraMax image is twice as wide and high as an ordinary image.



When an UltraMax image is captured by the camera, several ordinary images are saved in the same file. Capturing all the images can take up to 1 second. To fully utilize UltraMax, the images need to be slightly different, which can be accomplished by a slight movement of the camera. You should hold the camera firmly in your hands (do not put it on a tripod), which will make these images vary just a little during the capture. Correct focus, a high-contrast scene, and a non-moving target are other conditions that help to achieve a good-quality UltraMax image.

11.1 Window elements: the *Library* tab

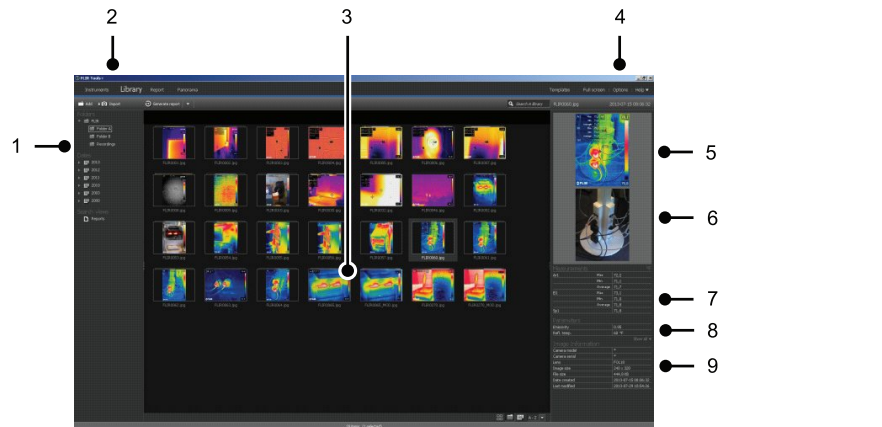
11.1.1 Figure



11.1.2 Explanation

1. Folder pane.
 2. Program tabs:
 - *Instruments* (e.g., meters or infrared cameras).
 - *Library*.
 - *Report*.
 - *Panorama*.
 3. Thumbnail view of selected folders.
 4. Menu bar:
 - *Templates*.
 - *Full screen*.
 - *Options*.
 - *Help*.
 5. Thumbnail view of the infrared image.
 6. Thumbnail view of the digital photo (if available).
 7. Measurement pane.
- Note** A  icon in the result table indicates that the measurement result is above or below the calibrated temperature range of the infrared camera and is therefore incorrect. This phenomenon is called *overflow* or *underflow*.
- A  icon in the result table indicates that the measurement result is too close to the calibrated temperature range of the infrared camera and is therefore unreliable.
8. Parameters pane.
 9. Image information pane

11.2 Window elements: the *Instruments* tab

Note The *Instruments* tab will only become available when a camera in UVC mode or a METERLiNK device is connected to the computer.

11.2.1 Figure

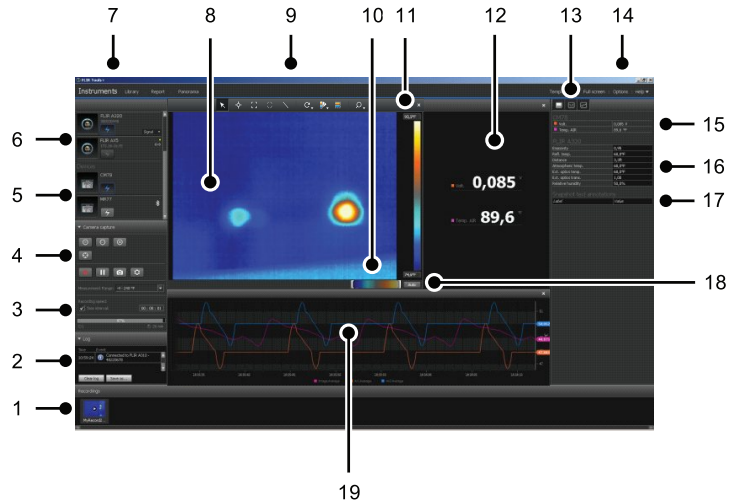

11.2.2 Explanation

1. Recordings pane.
2. Log area.
3. Recording speed, time interval controls, and temperature range.

Note For FLIR Ax5 series cameras, the *High* selection in the *Temperature range* drop-down menu refers to *high gain*, i.e., a low temperature range, and vice versa.

4. Camera-related controls:
 - Focusing the camera.
 - Calibrating the camera.
 - Recording a sequence, pausing a sequence, and resuming a sequence.
 - Saving a single snapshot as a *.jpg file.
 - Selecting the measurement range.
- In the *Options* dialog box (opens by clicking the  button):
 - Setting the file name prefix.
 - Setting the storage location for sequence files (*.seq, *.csq).
 - Setting the maximum amount of disk usage.
5. Button to connect to a Bluetooth-enabled device (e.g., a meter)
6. Button to connect a camera.
7. Program tabs.
8. Image window.
9. Toolbar buttons.
10. Sliders to adjust the bottom and top temperature levels in the scale (in effect, changing the histogram).
11. Temperature scale.
12. Measurements window (results from the connected device, e.g., a meter)
13. Toolbar buttons:
 - Show/hide thermal camera view.
 - Show/hide measurements view.
 - Show/hide plot view.

14. Menu bar:

- *Templates.*
- *Full screen.*
- *Options.*
- *Help.*

15. Measurements and parameters pane (devices).

16. Measurements and parameters pane (thermal cameras).

Note A  icon in the result table indicates that the measurement result is above or below the calibrated temperature range of the infrared camera and is therefore incorrect. This phenomenon is called *overflow* or *underflow*.

A  icon in the result table indicates that the measurement result is too close to the calibrated temperature range of the infrared camera and is therefore unreliable.

17. Annotations pane.

18. Auto-adjust button.

19. Plot window.

For more information, see section 14.15 *Creating a plot*, page 45 and 23.1.2 *The Options dialog (for plot-specific options)*, page 110.

11.3 Window elements: the *Create imagesheet* tab

11.3.1 Figure

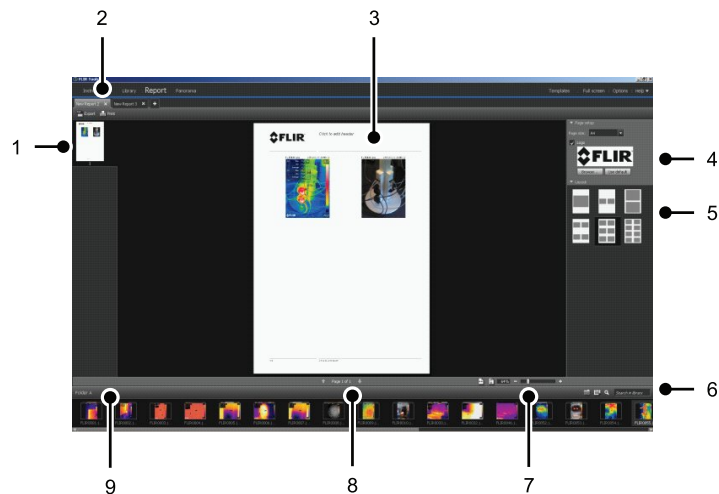

11.3.2 Explanation

1. Thumbnail view of the current page.
2. Tabs to go to the different imagesheets that are currently open.
3. Detail view of the current imagesheet page.
4. Page setup, where a company logo and the paper size can be selected.
5. Page layout setup.
6. Text box to search and filter the images.
7. Zoom controls.
8. Page controls.
9. Images in the currently selected folder.

11.4 Window elements: the *Report* tab

11.4.1 Figure

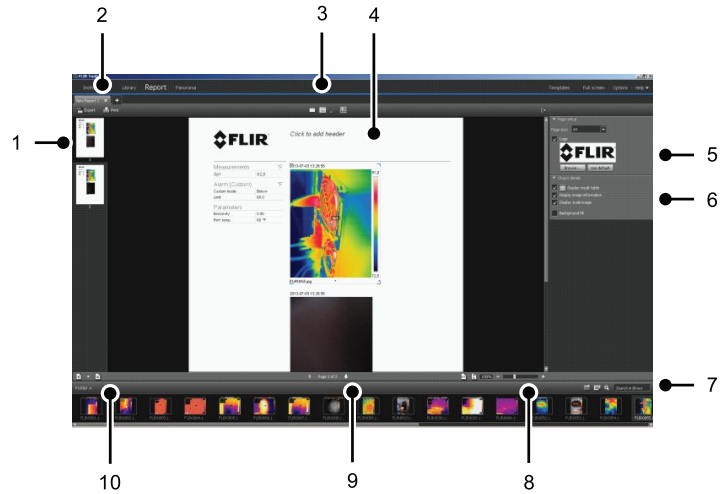

11.4.2 Explanation

1. Thumbnail view of the current report page.
2. Tabs to go to the different reports that are currently open.
3. Toolbar buttons.
4. Detail view of the current report page.
5. Page setup, where logos and paper size can be selected.
6. Area for image object details and voice comments.
7. Text box to search and filter the images.
8. Zoom controls.
9. Page controls.
10. Images in the currently selected folder.

11.5 Window elements: the image-editing window (for still images)

11.5.1 Figure

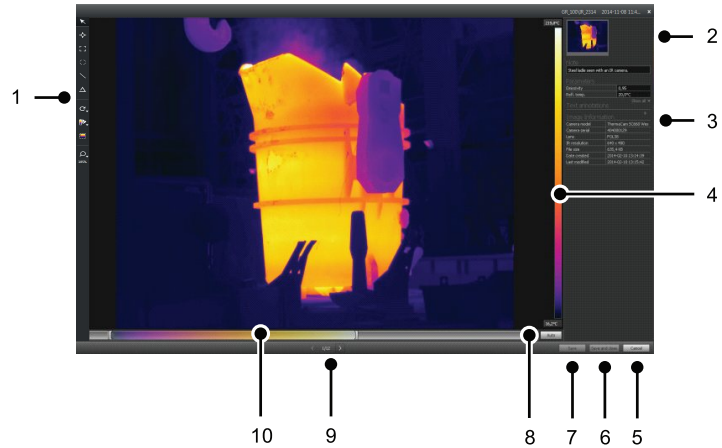

11.5.2 Explanation

1. Measurement toolbar.
2. Thumbnail view of the infrared image (and digital photo, if available).
3. Additional panes:
 - *Notes.*
 - *Measurements.*
 - *Parameters.*
 - *Text annotations.*
 - *Image information.*
4. Temperature scale.
5. Cancel button.
6. Save and close button.
7. Save button.
8. Auto-adjust button, to adjust the image for the best brightness and contrast.
9. Previous/Next buttons.
10. Temperature span and level control.

11.6 Window elements: the image-editing window (for video clips)

11.6.1 Figure

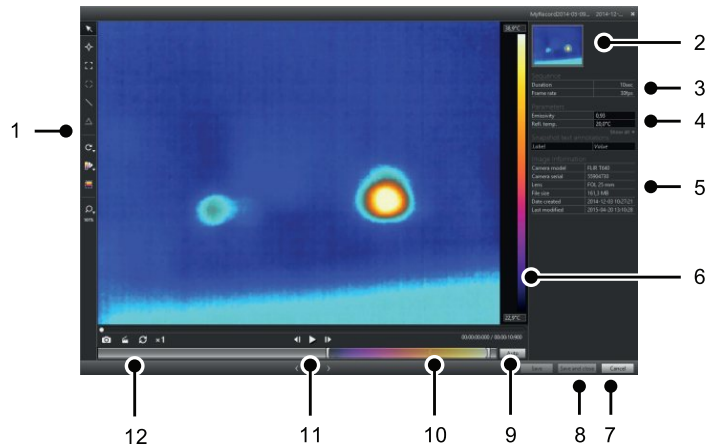





11.6.2 Explanation





1. Measurement toolbar.
2. Thumbnail view of the video clip.
3. Information about the sequence file.
4. Measurement and parameters pane.
5. Image information pane.
6. Temperature scale.
7. Cancel button.
8. Save and close button.
9. Auto-adjust button, to adjust the image for the best brightness and contrast.
10. Temperature span and level control.
11. Play/pause and forward/backward buttons.
12. Buttons to save a snapshot as a *.jpg file, to export the video clip as an *.avi file, and to change the playback speed (-60x to +60x).

Note Exporting a video clip as an *.avi file requires that FFDSHOW has been installed on the computer. FFDSHOW can be downloaded from <http://www.free-codecs.com>.

11.7 Toolbar buttons (on the *Instruments* tab)

Note The *Instruments* tab will only become available when a camera in UVC mode or a METERLiNK device is connected to the computer.

	Selection tool.
	Spotmeter tool.
	Area tool.
	Line tool.
	Circle and ellipsis tool.





	Rotate right/left tool.
	Color palette tool.
	Auto-adjust region tool.
	Zoom tool.

11.8 Toolbar buttons (in the image-editing window)

	Selection tool.
	Spotmeter tool.
	Area tool.
	Circle and ellipsis tool.
	Line tool.
	Difference tool.
	Rotate right/left tool.
	Color palette tool.
	Thermal MSX tool.
	Thermal tool.
	Thermal fusion tool.
	Thermal blending tool.
	Picture-in-picture tool.
	Digital photo tool.
	Tool to change picture-in-picture.
	Tool to change thermal/photo balance.

	Auto-adjust region tool.
	Zoom tool.

11.9 Toolbar buttons (in the report-editing window)

	Text annotation tool.
	Textbox tool.
	Arrow marker tool.
	Snap objects to grid.

11.10 The *Panorama* tab

11.10.1 Figure

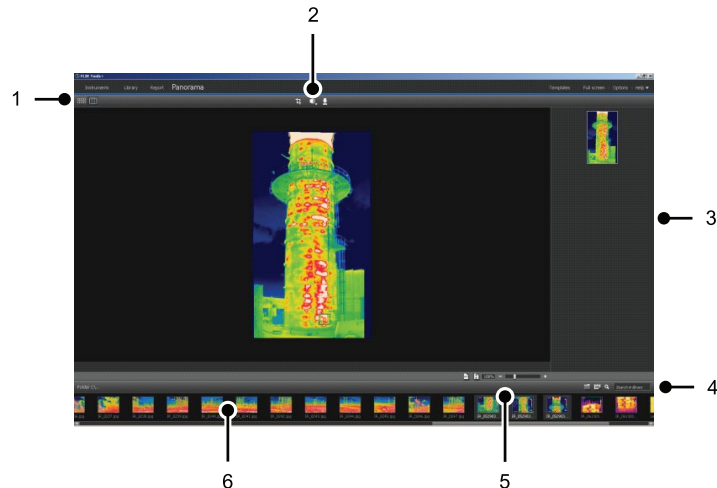

11.10.2 Explanation

- Buttons to switch between source file view and panorama view.
- Buttons to crop the panorama image, to correct the perspective, and to save the panorama image.
- Pane where all panorama images created from the selected images are displayed.
- Buttons to change the folder, select images by date, and search images.
- Buttons to zoom into and out of the panorama image.
- Pane displaying the source files in the currently selected folder.

Live image streaming of camera images

12.1 General

You can connect an infrared camera to FLIR Tools/Tools+ and display its live image stream on the *Instruments* tab. When the camera is connected, you can lay out measurement tools, change parameters, create plots, etc.

12.2 Figure

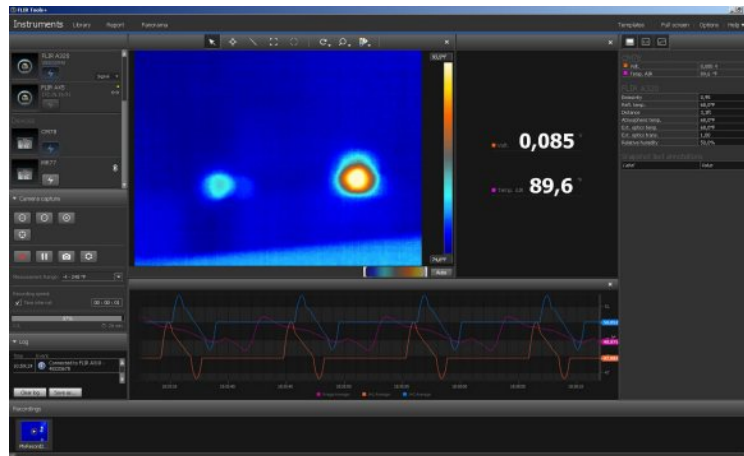

Figure 12.1 The *Instruments* tab.

12.3 Procedure

Note The tasks in Step 5 below only apply to cameras with radiometric streaming.

Follow this procedure:

1. Start FLIR Tools/Tools+.
2. Turn on the infrared camera.
3. Connect the camera to the computer, using a USB cable. This displays an import guide.

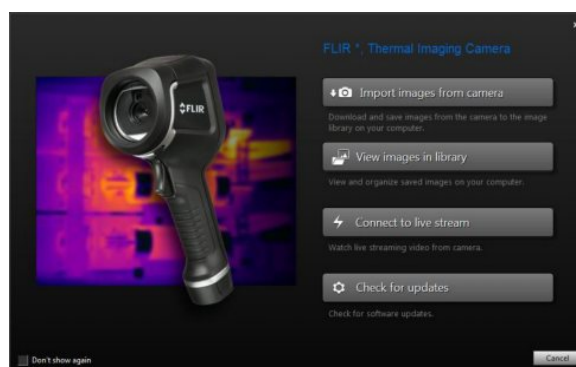











Figure 12.2 Import guide (example).

Note For some older camera models, you need to set the USB mode to *mass storage device* (MSD) or *mass storage device—UVC* (MSD-UVC).

4. Click *Connect to livestream*. This displays the live image stream from the camera on the *Instruments* tab.

5. On the *Instruments* tab, do one or more of the following:

- To adjust camera focus, click the  button (near focus), the  button (auto-focus), or the  button (far focus).
- To calibrate the camera, click the  button.
- To start a recording, click the  button.
- To stop a recording, click the  button.
- To freeze the live image stream, click the  toolbar button.
- To save a single snapshot as a *.jpg file, click the  button.
- To change a number of recording settings, click the  button. This displays a dialog box.
- To display the live image stream of another camera on the network, click the  button for that camera.
- To lay out a measurement tool, click the tool and then click on the image.
- To change parameters, click the value field of a parameter, type a new value, and press Enter.
- To create a plot, right-click the image and then select the type of plot you want.
For more information, see section 14.15 *Creating a plot*, page 45 and 23.1.2 *The Options dialog (for plot-specific options)*, page 110.

Note The *Instruments* tab will only become available when a camera in UVC mode or a METERLiNK device is connected to the computer.

13.1 Grouping files

13.1.1 General

You can group files together, e.g., one infrared image and one digital photo, or one infrared image and a plot. When two files are grouped, a link is created and the images act as a pair through the reporting process.

13.1.2 Procedure

Follow this procedure:

1. Go to the *Library* tab.
2. In the image window, select two files.
3. Right-click the images and click *Group*.

13.2 Saving a sequence file frame as a radiometric *.jpg file

13.2.1 General

You can save a sequence file frame as a radiometric *.jpg image.

13.2.2 Procedure

Follow this procedure:

1. Go to the *Library* tab.
2. Double-click a sequence file (file suffix *.seq, *.csq).
3. Go to the point of interest in the sequence file, using the playback controls.
4. Click the  toolbar button. This will open a *Save as* dialog box where you can navigate to the location where you want to save the file.

13.3 Saving a sequence file frame as an *.avi file

13.3.1 General

You can save a sequence file frame as an *.avi file.

Note Exporting a video clip as an *.avi file requires that FFDSHow has been installed on the computer. FFDSHow can be downloaded from <http://www.free-codecs.com>.

13.3.2 Procedure

Follow this procedure:

1. Go to the *Library* tab.
2. Double-click a sequence file (file suffix *.seq, *.csq).
3. Click the  toolbar button. This will open a *Save as* dialog box where you can navigate to the location where you want to save the file.

13.4 Changing the playback speed

13.4.1 General

You can change the playback speed of video clips between -60x and +60x.

13.4.2 Procedure

Follow this procedure:

1. Go to the *Library* tab.
2. Double-click a sequence file (file suffix *.seq, *.csq).
3. Click the  toolbar button and select a playback speed by dragging the slider.

13.5 Cloning images

13.5.1 General

You can create copies of one or more images. This is called *cloning*.

13.5.2 Procedure

Follow this procedure:

1. Go to the *Library* tab.
2. Select the image or images that you want to clone.
3. On the right-click menu, click *Clone*.

13.6 Extracting a digital camera photo from a multispectral image

13.6.1 General

For cameras supporting multispectral images, all image modes are included inside a single image file—MSX, thermal, thermal fusion, thermal blending, picture-in-picture, and the digital camera photo.

You can extract a digital camera photo from this multispectral image. The field of view of the extracted photo will match the field of view of the thermal image. Additionally, you can extract a photo at its full field of view.

13.6.2 Procedure: Extracting a photo

Follow this procedure:

1. Go to the *Library* tab.
2. Select the image for which you want to extract the digital camera photo.
3. On the right-click menu, click *Extract photo*.

13.6.3 Procedure: Extracting a photo at its full field of view

Follow this procedure:

1. Go to the *Library* tab.
2. Select the image for which you want to extract the digital camera photo.
3. On the right-click menu, click *Extract full photo*.

13.7 Enhancing the resolution of an image

13.7.1 General

Some cameras from FLIR Systems support enhancing the resolution of images by using a feature called UltraMax.

13.7.2 Indication of supported images

Supported images are indicated by a special icon on the *Library* tab. See the bottom right corner in the figure below.



13.7.3 Procedure

Follow this procedure:

1. Go to the *Library* tab.
2. Right-click an image that has the icon shown above.
3. Select one of the following:
 - *Enhance image resolution (UltraMax)*.
 - *Enhance image resolution (UltraMax) and backup original images*.

13.8 Deleting images

13.8.1 General

You can delete one image or a group of images.

13.8.2 Procedure

Follow this procedure:

1. Go to the *Library* tab.
2. In the image window, select the image or images that you want to delete.
3. Do one of the following:
 - Press the DELETE key and confirm that you want to delete the image or images.
 - Right-click the image or images, select *Delete*, and confirm that you want to delete the image or images.

Note

- When you delete an image or a group of images, you can restore them from the computer's Recycle Bin.
- You can also remove images by deleting the path under *Options > Library*. Removing the path does not delete the images.

13.9 Adding a directory

13.9.1 General

You can add a directory to the library.

13.9.2 Procedure

Follow this procedure:

1. Go to the *Library* tab.
2. At the top of the left pane, click *Add to library*. This will open a *Browse for folder* dialog box where you can navigate to the directory that you want to add.

Note Only subdirectories can be deleted. Root directories can only be removed by deleting the path under *Options > Library*. Removing the path does not delete the images.

13.10 Deleting a directory

13.10.1 General

You can delete a directory from the library.

13.10.2 Procedure

Follow this procedure:

1. Go to the *Library* tab.
2. Right-click a directory and select *Delete directory*.

Note Only subdirectories can be deleted. Root directories can only be removed by deleting the path under *Options > Library*. Removing the path does not delete the images.

13.11 Creating a subfolder

13.11.1 General

You can create a subfolder to an existing directory in the library.

13.11.2 Procedure

Follow this procedure:

1. Go to the *Library* tab.
2. Right-click a directory and select *Create subfolder*.

14.1 Laying out a measurement tool

14.1.1 General

You can lay out one or more measurement tools on an image, e.g., a spotmeter, an area, a circle, or a line.

Note A  icon in the result table indicates that the measurement result is above or below the calibrated temperature range of the infrared camera and is therefore incorrect. This phenomenon is called *overflow* or *underflow*.

A  icon in the result table indicates that the measurement result is too close to the calibrated temperature range of the infrared camera and is therefore unreliable.

14.1.2 Procedure

Follow this procedure:

1. On the *Library* tab, double-click an image.
2. On the image toolbar, select a measurement tool.
3. To lay out the measurement tool on the image, click the location where the measurement tool is to be placed.

Note You can also do this by double-clicking an image on a report page and then following the procedure above. In this case, only the image in the report will be changed, not the image in the library.

14.2 Moving a measurement tool

14.2.1 General

Measurement tools that you have laid out on an image can be moved around, using the selection tool.

14.2.2 Procedure

Follow this procedure:

1. On the *Library* tab, double-click an image.
2. On the image toolbar, select .
3. On the image, select the measurement tool and drag it to a new position.

Note Measurement tools can also be moved on report pages. In this case, only the image in the report will be changed, not the image in the library.

14.3 Resizing a measurement tool

14.3.1 General

Measurement tools that you have laid out on an image, e.g., an area, can be resized using the selection tool.

14.3.2 Procedure

Follow this procedure:

1. On the *Library* tab, double-click an image.
2. On the image toolbar, select .

3. On the image, select the measurement area and use the selection tool to drag the handles that are displayed around the frame of the area:

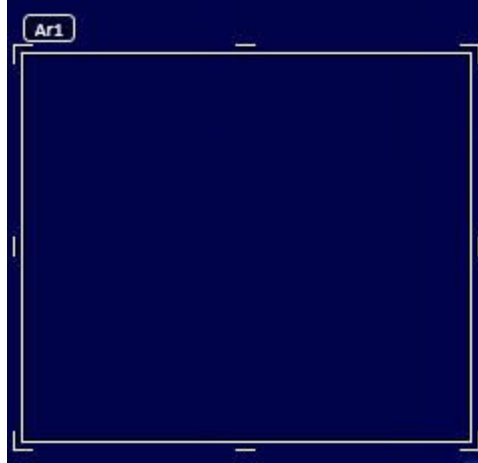

Note Measurement tools can also be resized on report pages. In this case, only the image in the report will be changed, not the image in the library.

14.4 Deleting a measurement tool

14.4.1 General

You can delete any measurement tools that you have laid out on an image.

14.4.2 Procedure

Follow this procedure:

1. On the *Library* tab, double-click an image.
2. On the image toolbar, select .
3. On the image, select the measurement tool and press DELETE.

14.5 Creating local markers for a measurement tool

14.5.1 General

When images are imported from the camera to FLIR Tools, the program will respect any existing markers for a measurement tool in the image. However, sometimes you may want to add a marker when analyzing the image in FLIR Tools: you do this by using *local markers*.

14.5.2 Procedure

Follow this procedure:

1. On the *Library* tab, double-click an image for which, for example, a measurement area has already been laid out in the camera.
2. Right-click the area and select *Local min/max/avg markers*.
3. Select or clear the markers that you want to add or remove.
4. Click *OK*.

14.6 Setting local parameters for a measurement tool

14.6.1 General

In some situations you may want to change a measurement parameter for one measurement tool only. The reason for this could be that the measurement tool is in front of a significantly more reflective surface than other surfaces in the image, or over an object that is further away than the rest of the objects in the image, and so on.

For more information about object parameters, see section 27 *Thermographic measurement techniques*, page 129.

14.6.2 Procedure

Follow this procedure:

1. On the *Library* tab, double-click an image.
2. Lay out a measurement tool, e.g., an area.
3. Right-click the area and select *Use local parameters*.
4. In the dialog box, select *Use local parameters*.
5. Enter a value for one or more parameters.
6. Click *OK*.

Note Local parameters in an image are indicated by a white information icon in the *Measurements* pane.

14.7 Working with isotherms

14.7.1 General

The isotherm command applies a contrasting color to all pixels with a temperature above, below, or between one or more set temperature levels.

Using isotherms is a good method to easily discover anomalies in an infrared image.

14.7.2 Setting up general isotherms (*Above, Below*)

14.7.2.1 General

An isotherm of the type *Above* and *Below* will colorize areas with a temperature *above* or *below* a set temperature.

14.7.2.2 Procedure

Follow this procedure:

1. On the *Library* tab, double-click an image.
2. On the image toolbar, click , and select one of the following:
 - *Above*.
 - *Below*.
3. In the right pane, take note of the parameter *Limit*. Areas in the image with a temperature *above* or *below* this temperature will be colorized with the isotherm color. You can change this limit, and also change the isotherm color on the *Color* menu.

14.7.3 Setting up general isotherms (*Interval*)

14.7.3.1 General

An isotherm of the type *Interval* will colorize areas with a temperature *between* two set temperatures.

14.7.3.2 Procedure

Follow this procedure:

1. On the *Library* tab, double-click an image.
2. On the image toolbar, click , and select *Interval*.
3. In the right pane, take note of the parameters *Upper limit* and *Lower limit*. Areas in the image with a temperature between these two temperatures will be colorized with the isotherm color. You can change these limits, and also change the isotherm color on the *Color* menu.

14.7.4 Setting up a humidity isotherm

14.7.4.1 General

The humidity isotherm can detect areas where there is a risk of mold growing, or where there is a risk of the humidity falling out as liquid water (i.e., the dew point).

14.7.4.2 Procedure

Follow this procedure:

1. On the *Library* tab, double-click an image.
2. On the image toolbar, click , and select *Humidity*. Depending on your object, certain areas will now be colorized with an isotherm color.
3. In the right pane, take note of the parameter *Calculated limit*. This is the temperature at which there is a risk of humidity. If the parameter *Relative humidity limit* is set to 100%, this is also the *dew point*, i.e., the temperature at which the humidity falls out as liquid water.

Note The parameter *Calculated limit* takes the following three parameters into account:

- Relative humidity.
- Relative humidity limit.
- Atmospheric temperature.

14.7.5 Setting up an insulation isotherm

14.7.5.1 General

The insulation isotherm can detect areas where there may be an insulation deficiency in the building. It will trigger when the insulation level falls below a preset value of the energy leakage through the building structure—the so-called *thermal index*.

Different building codes recommend different values for the thermal index, but typical values are 0.6–0.8 for new buildings. Refer to your national building code for recommendations.

14.7.5.2 Procedure

Follow this procedure:

1. On the *Library* tab, double-click an image.
2. On the image toolbar, click , and select *Insulation*. Depending on your object, certain areas will now be colorized with an isotherm color.
3. In the right pane, take note of the parameter *Calculated insulation*. This is the temperature where the insulation level falls below a preset value of the energy leakage through the building structure.

Note The parameter *Calculated insulation* takes the following three parameters into account:

- Indoor temperature.
- Outdoor temperature.
- Thermal index.

14.7.6 Setting up a custom isotherm

14.7.6.1 General

A custom isotherm is an isotherm of any of the following types:

- *Above*.
- *Below*.
- *Interval*.
- *Humidity*.
- *Insulation*.

For these custom isotherms, you can specify a number of different parameters manually, compared with using the standard isotherms:

- *Background*.
- *Colors* (semi-transparent or solid colors).
- *Inverted color* (for the *Interval* isotherm only).

14.7.6.2 Procedure

Follow this procedure:

1. On the *Library* tab, double-click an image.
2. On the image toolbar, click , and select *Custom*.
3. In the right pane, specify the following parameters:
 - For *Above* and *Below*:
 - *Background*.
 - *Limit*.
 - *Color*.
 - For *Interval*:
 - *Background*.
 - *Upper limit*.
 - *Lower limit*.
 - *Color*.
 - *Inverted interval*.
 - For *Humidity*:
 - *Background*.
 - *Color*.
 - *Relative humidity*.
 - *Relative humidity limit*.
 - *Atmospheric temperature*.
 - For *Insulation*:
 - *Background*.
 - *Color*.
 - *Indoor temperature*.
 - *Outdoor temperature*.
 - *Thermal index*.

14.8 Changing the temperature levels

14.8.1 General

At the bottom of the infrared image you will see two sliders. By dragging these sliders to the left or to the right you can change the top and bottom levels in the temperature scale.

14.8.2 Why change temperature levels?

The reason to change the temperature levels manually is that it makes it easier to analyze a temperature anomaly.

14.8.2.1 Example 1

Here are two infrared images of a building. In the left image, which is auto-adjusted, the large temperature span between the clear sky and the heated building makes a correct analysis difficult. You can analyze the building in more detail if you change the temperature scale to values close to the temperature of the building.

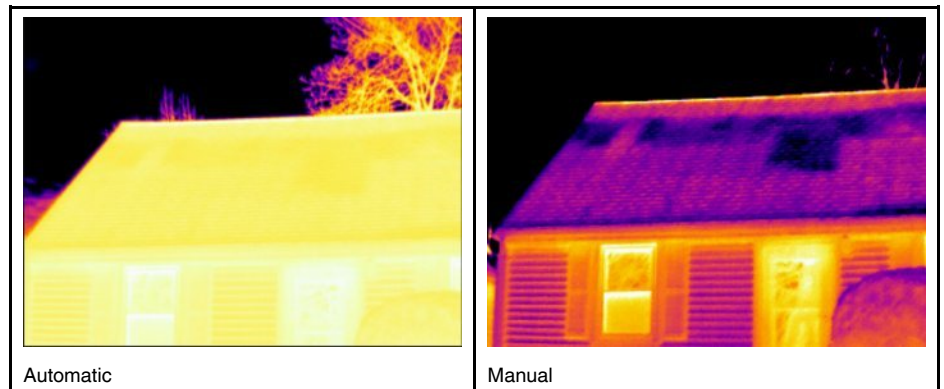

14.8.2.2 Example 2

Here are two infrared images of an isolator in a power line. To make it easier to analyze the temperature variations in the isolator, the temperature scale in the right image has been changed to values close to the temperature of the isolator.

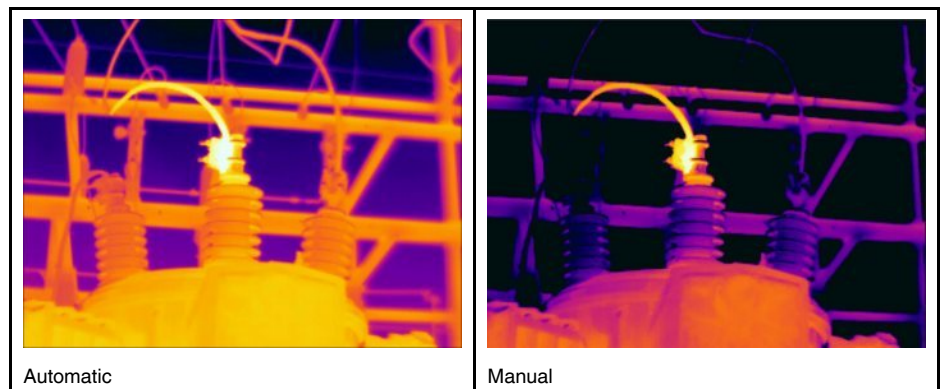

14.8.3 Changing the top level

Follow this procedure:

1. Drag the right slider right or left to change the top level in the temperature scale.

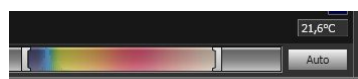

14.8.4 Changing the bottom level

Follow this procedure:

1. Drag the left slider right or left to change the bottom level in the temperature scale.



14.8.5 Changing both the top and bottom levels at the same time

Follow this procedure:

1. SHIFT-drag the left or right slider right or left to change both the top and the bottom levels in the temperature scale at the same time.



Note

- You can adjust the temperature levels by using the mousewheel.
- You can adjust the temperature span by holding down the CTRL key while using the mousewheel.
- You can double-click the temperature levels scale to auto-adjust the image.
- You can change the temperature levels by double-clicking an image on a report page and then dragging the sliders. In this case, only the image in the report will be changed, not the image in the library.

14.9 Auto-adjusting an image

14.9.1 General

You can auto-adjust an image or a group of images. When you auto-adjust an image you adjust it for the best image brightness and contrast. This means that the color information is distributed over the existing temperatures of the image.

14.9.2 Procedure

Follow this procedure:

1. To auto-adjust an image, do one of the following:
 - Double-click the temperature scale.



- Click the *Auto* button.

Note You can also do this by double-clicking an image on a report page and then following the procedure above. In this case, only the image in the report will be changed, not the image in the library.

14.10 Defining an auto-adjust region

14.10.1 General

When you click the temperature scale or the *Auto* button in the image window, the whole image is auto-adjusted. This means that the color information is distributed over the temperatures in the image.

However, in some situations the still image or the video image may contain very hot or cold areas outside your area of interest. In such cases you will want to exclude those areas and use the color information only for the temperatures in your area of interest. You can do so by defining an auto-adjust region.

14.10.2 Procedure

Follow this procedure:

1. On the *Library* tab, double-click an image.
2. In the image window, click the  button on the top toolbar. This will display a tool with which you can create a region. The region can be moved and resized to suit your area of interest, but will not be saved in the image.

14.11 Changing the color distribution

14.11.1 General

You can change the distribution of colors in an image. A different color distribution can make it easier to analyze the image more thoroughly.

14.11.2 Definitions

You can choose from three different color distributions:

- *Histogram equalization*: This is an image-displaying method that distributes the color information over the existing temperatures of the image. This method of distributing the information can be particularly successful when the image contains few peaks at very high temperature values.
- *Signal linear*: This is an image-displaying method where the color information in the image is distributed linearly to the signal values of the pixels.
- *Temperature linear*: This is an image-displaying method where the color information in the image is distributed linearly to the temperature values of the pixels.

14.11.3 Procedure

Follow this procedure:

1. Go to the *Library* tab.
2. Double-click the image for which you want to change the color distribution.
3. On the right-click menu, click *Color distribution* and select *Histogram equalization*, *Signal linear*, or *Temperature linear*.

14.12 Changing the palette

14.12.1 General

You can change the palette that the camera uses to display the different temperatures within an image. A different palette can make it easier to analyze the image.

14.12.2 Procedure

Follow this procedure:

1. On the *Library* tab, double-click an image.
2. In the image window, click the  button on the top toolbar. This will display a drop-down menu.
3. On the menu, click the palette that you want to use.





Note You can also do this by double-clicking an image on a report page and then following the procedure above. In this case, only the image in the report will be changed, not the image in the library.

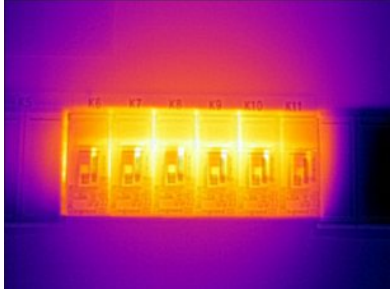

14.13 Changing the image mode

14.13.1 General

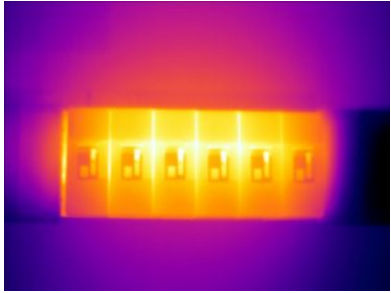
For some images you can change the image mode. You do this on the toolbar in the image-editing window.

14.13.2 Types of image modes

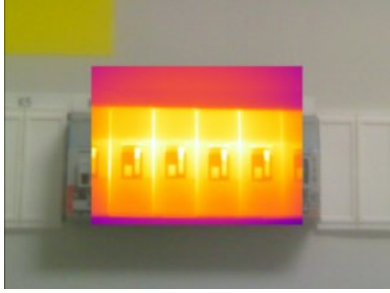
Button	Image mode	Image example
	<i>Thermal MSX</i> (Multi Spectral Dynamic Imaging): This mode displays an infrared image where the edges of the objects are enhanced. Note that the label for each fuse is clearly legible.	
	<i>Thermal</i> : This mode displays a fully infrared image.	
	<i>Thermal fusion</i> : This mode displays a digital photo where some parts are displayed in infrared, depending on the temperature limits.	

Button	Image mode	Image example
	<i>Picture-in-picture</i> : This mode displays an infrared image frame on top of a digital photo.	
	<i>Digital camera</i> : This mode displays a fully digital photo.	

14.14 Exporting to CSV

14.14.1 General

You can export the content of an image as a matrix of comma-separated values for further analysis in external software. The file format is *.csv, and the file can be opened in Microsoft Excel.

14.14.2 Procedure

Follow this procedure:

1. On the *Library* tab, double-click an image.
2. Right-click the image and select *Export to CSV*. This displays a dialog box.
3. In the dialog box, do one of the following:
 - To export the image, select *Image* in the drop-down menu. Additionally, select whether to include object parameters and text annotations.
 - To export the measurements, select *Measurements* in the drop-down menu. Additionally, select whether to include object parameters, text annotations, and the values of measurement tools.

14.15 Creating a plot

14.15.1 General

When FLIR Tools/Tools+ is connected to a camera that supports radiometric streaming, you can create a plot. A plot displays how the results of one or several measurement tools vary over time.

14.15.2 Procedure

Follow this procedure:

1. Start FLIR Tools/Tools+.
2. Turn on the infrared camera.

- Connect the camera to the computer, using a USB cable. This displays an import guide.

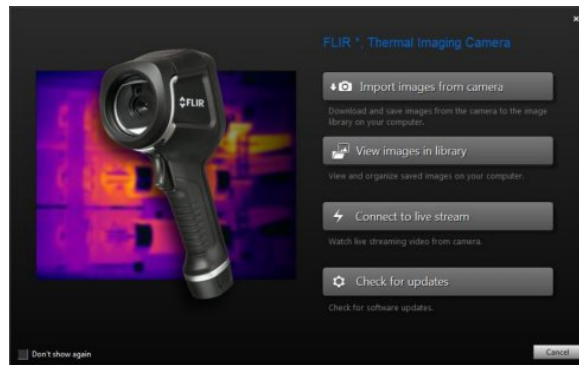







Figure 14.1 Import guide (example).

Note For some older camera models, you need to set the USB mode to *mass storage device* (MSD) or *mass storage device—UVC* (MSD-UVC).

- Click *Connect to livestream*. This displays the live image stream from the camera on the *Instruments* tab.
- On the *Instruments* tab, right-click the image and then select the type of plot you want. You can choose between the following types:

- *Points*: This displays the plot as a series of points. 
- *Line*: This displays the plot as a line. 
- *Area*: This displays the plot as a colored area. 
- *Digital Line*: This displays the plot as a digital line, i.e., a line with no interpolation between the data points. 
- *Digital Area*: This displays the plot as a colored digital area, i.e., an area below a line with no interpolation between the data points. 
- *Impulse*: This displays the plot as a series of vertical impulses, with a circular end-point. 

- Right-click the image again and select *Options* if you want to change certain aspects of the plot.

For more information, see section 23.1.2 *The Options dialog (for plot-specific options)*, page 110.

14.16 Calculating areas

14.16.1 General

The distance included in the image parameter data can be used as the basis for area calculations. A typical application is to estimate the size of a damp stain on a wall.

To calculate the area of a surface, you need to add a box or circle measurement tool to the image. FLIR Tools/Tools+ calculates the area of the surface enclosed by the box or circle tool. The calculation is an estimate of the surface area, based on the distance value.

14.16.1.1 Procedure

Follow this procedure:

1. Add a box or circle measurement tool, see section 14.1 *Laying out a measurement tool*, page 36.
2. Adjust the size of the box or circle tool to the size of the object, see section 14.3 *Resizing a measurement tool*, page 36.
3. Right-click the tool and select *Local min/max/avg markers*. In the dialog box, select the *Area* check box. This displays the calculated area, based on the distance value, in the *Measurements* pane.
4. To change the distance value, click the value field in the *Parameters* pane, type a new value, and press Enter. The recalculated area, based on the new distance value, is displayed in the *Measurements* pane.

14.17 Calculating lengths

14.17.1 General

The distance included in the image parameter data can be used as the basis for length calculations.

To calculate the length, you need to add a line measurement tool to the image. FLIR Tools/Tools+ calculates an estimate of the line length, based on the distance value.

14.17.1.1 Procedure

Follow this procedure:

1. Add a line measurement tool, see section 14.1 *Laying out a measurement tool*, page 36.
2. Adjust the size of the line tool to the size of the object, see section 14.3 *Resizing a measurement tool*, page 36.
3. Right-click the tool and select *Local min/max/avg markers*. In the dialog box, select the *Length* check box. This displays the calculated length, based on the distance value, in the *Measurements* pane.
4. To change the distance value, click the value field in the *Parameters* pane, type a new value, and press Enter. The recalculated area, based on the new distance value, is displayed in the *Measurements* pane.

15.1 About image descriptions

15.1.1 What is an image description?

An image description is a brief free-form textual description that is stored in an infrared image file. It uses a standard tag in the *.jpg file format and can be retrieved by other software.

15.1.1.1 Procedure

Follow this procedure:

1. On the *Library* tab, double-click an image.
2. In the right pane, type the image description in the field under *Image description*.

Note You can edit existing image descriptions on the final report pages, but you cannot create new image descriptions there.

15.2 About text annotations

15.2.1 What is a text annotation?

A *text annotation* is textual information about something in an image and is constructed of a group of information pairs—*label* and *value*. The reason for using text annotations is to make reporting and post-processing more efficient by providing essential information about the image, e.g., conditions, photos, and information about where an image is taken.

A text annotation is a proprietary annotation format from FLIR Systems, and the information cannot be retrieved by other vendors' software. The concept relies heavily on *interaction by the user*. In the camera, the user can select one of several values for each label. The user can also enter numerical values, and make the text annotation capture measurement values from the screen.

15.2.2 Definition of label and value

The concept of *text annotation* is based on two important definitions—*label* and *value*. The following examples explain the difference between the two definitions.

Company	Company A Company B Company C
Building	Workshop 1 Workshop 2 Workshop 3
Section	Room 1 Room 2 Room 3
Equipment	Tool 1 Tool 2 Tool 3
Recommendation	Recommendation 1 Recommendation 2 Recommendation 3

Note

- In some cameras and software, *text annotation* is called *text comment* or *table*.
- In some cameras and software, *label* is called *field*.

15.2.3 Example markup structure

The file format for a text annotation is *.tcf. This code sample is an example markup structure of such a file and shows how the markup looks in Notepad. The words between pointed brackets are labels, and the words without pointed brackets are values.

```
<Company>
Company A
Company B
Company C
<Building>
Workshop 1
Workshop 2
Workshop 3
<Section>
Room 1
Room 2
Room 3
<Equipment>
Machine 1
Machine 2
Machine 3
<Recommendation>
Recommendation 1
Recommendation 2
Recommendation 3
```

15.2.4 Creating a text annotation for an image**15.2.4.1 General**

In FLIR Tools/Tools+, you can create a text annotation for an image. You do this in the image-editing window.

15.2.4.2 Procedure

Follow this procedure:

1. On the *Library* tab, double-click an image.
2. Under *Text annotations* in the right pane, click the  button (the '+' sign). This adds text annotation rows.
3. Enter the desired labels and values. See the image below for examples.



Text annotations	
Company	Flir Systems
Building	Production
<i>Label</i>	<i>Value</i>

4. Click *Save and close*.

15.2.5 Creating a text annotation template**15.2.5.1 General**

In FLIR Tools/Tools+, you can create text annotation templates on the *Templates* tab. These templates can either be transferred to the camera or used as a template during post-analysis in the program.

15.2.5.2 Procedure

Follow this procedure:

1. Click the *Templates* tab.
2. Click the *Add new text annotations template* toolbar button.
3. Create a name for the template.
4. Enter the desired fields and values. See the image below for examples.



The image shows a screenshot of a software interface titled "Example file". Below the title is a table with two columns: "Fields" and "Values". The table contains three rows of data. The first row has "Company" in the "Fields" column and "FLIR Systems" in the "Values" column. The second row has "Building" in the "Fields" column and "Warehouse" in the "Values" column. The third row is empty. A blue border highlights the "Warehouse" cell in the second row.

Fields	Values
Company	FLIR Systems
Building	Warehouse

5. Save the template.
6. Do one of the following:
 - To use the template in the camera, connect a camera to FLIR Tools/Tools+ and transfer the template to the camera.
 - To use the template during post-analysis in FLIR Tools/Tools+, double-click an image, and then click *Import from template* under *Text annotations* in the right pane.

16.1 General

In FLIR Tools+ you can create panoramas by stitching together several smaller images into a larger one. FLIR Tools+ analyzes each image to detect pixel patterns that match pixel patterns in other images.

You can then crop the panorama and carry out various perspective corrections.



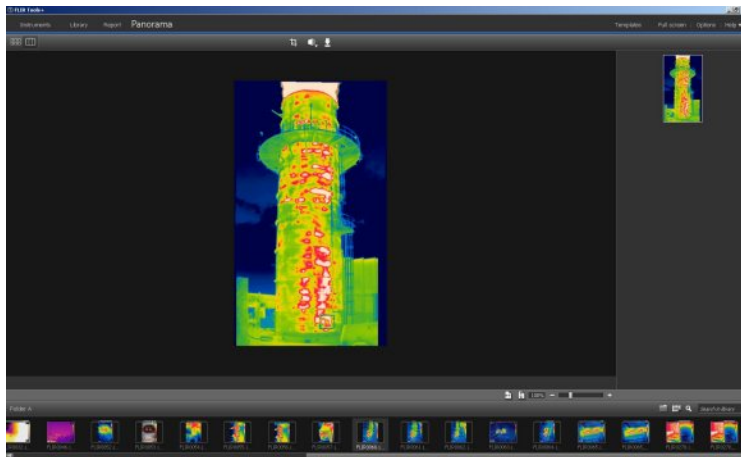

16.2 Figure

This figure shows the panorama workspace.



16.3 Procedure

Follow this procedure:

1. On the *Library* tab, select the images that you want to use when creating a panorama.
2. Right-click the images and select *Combine into panorama*. This will open the *Panorama* tab.
3. At this stage you can perform a variety of tasks:
 - Click  to crop the panorama.
 - Click  to carry out a perspective correction on the image.
 - Click  to save the panorama as an image file.
 - Click  to view the original source files.
 - Click  to view the final panorama.

For more information, see section 11.10 *The Panorama tab*, page 29.

17.1 General

You can create the following types of reports from the program:

1. **An Adobe PDF imagesheet:** This is a simple report format that contains only infrared and any associated visual images. The report cannot be edited further, and radiometric data is not included. For more information, see 17.4 *Creating an Adobe PDF imagesheet*, page 53.
2. **An Adobe PDF report:** This is a simple report format that contains infrared images, any associated visual images, and result tables. The report cannot be edited further, and radiometric data is not included. For more information, see section 17.5 *Creating an Adobe PDF report*, page 53
3. **A radiometric Microsoft Word report:** This is the most advanced report format, and requires an installation of FLIR Report Studio and an active FLIR Tools+/FLIR Report Studio license. A report in Microsoft Word *.docx file format is generated. Advanced radiometric analysis can be carried out using the FLIR Word Add-in features in Microsoft Word. For more information, see section 17.6 *Creating a radiometric Microsoft Word report*, page 54

Note

- The program ships with a number of report templates. You can also create your own radiometric Microsoft Word report templates, see section 20 *Creating report templates*, page 96.
- You can export a radiometric Microsoft Word report to a flat (non-radiometric) report or to a PDF report from the FLIR Word Add-in. For more information, see section 18.6 *Exporting a report*, page 75.
- You can also create Microsoft Word reports using the FLIR Report Studio wizard. For more information, see section 21 *Creating reports using the FLIR Report Studio wizard*, page 101.
- An Adobe PDF report can be saved in an intermediary format called *.repx. For more information, see section 17.3 *Saving a report in the intermediary *.repx format*, page 53

17.2 Setting a default report template

Prior to working with reports, you need to set a default report template. A maximum of two default report templates can be set. These templates will then be used when clicking *Generate report* on the *Library* tab.

Follow this procedure:

Note The first row of templates apply to FLIR Tools+ only.

1. On the *Library* tab, select any image and then click . This will display the available report templates.

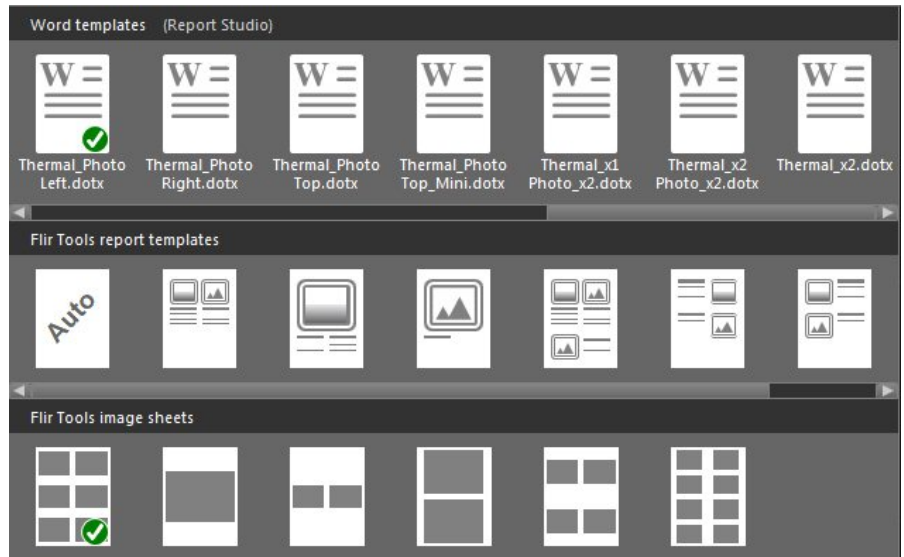

2. Right-click a report template and click *Set as default report template*.

17.3 Saving a report in the intermediary *.repx format

Follow this procedure:

1. On the *Library* tab, select the image or images that you want to include in your report.
2. Right-click the image or images and select *Create report*.
3. Under *Page setup* in the right pane, select the page size and logo that you want to use.
4. On the report, double-click the header and/or footer to add any header/footer text that you want to use.
5. Click *Save* or *Save As* to save the report in FLIR Systems *.repx file format.

17.4 Creating an Adobe PDF imagesheet

Follow this procedure:

1. On the *Library* tab, select the image or images that you want to include in your imagesheet.
2. Right-click the image or images and select *Create imagesheet*.
3. Under *Page setup* on the right pane, select the page size and logo that you want to use.
4. Under *Layout* on the right pane, click the page layout that you want to use.
5. On the imagesheet, double-click the header and/or footer to add any header/footer text that you want to use.
6. Click *Export* to export the imagesheet as a PDF file.

17.5 Creating an Adobe PDF report

Note This procedure assumes that an Adobe PDF report has been set as a default template.

Follow this procedure:

1. On the *Library* tab, select the image or images that you want to include in your report.
2. Right-click the image or images and select *Create report*. This displays the *Report* tab.
3. At this stage, you have the option to do one or more of the following:
 - Drag a group of images, photos, or text annotations into a report.
 - Drag single images, photos, or tables into a report.
 - Reorder the pages in the report.
 - Enter text in a report using textboxes.
 - Create and edit text annotations.
 - Edit image descriptions.
 - Add and edit a header or footer in a report.
 - Move and delete images, photos, text annotations, and tables in a report.
 - Resize images in a report.
 - Update measurements in an infrared image and see updates instantly in the result table.
 - Zoom into and out of a report page.
 - Add arrow markers to the image or any other object in the report.
 - Edit an image from the report by double-clicking the image.
4. In the *Save PDF as* dialog box, select a location and type a filename.
5. Click *OK*.

17.6 Creating a radiometric Microsoft Word report

Note

- This procedure assumes that a Microsoft Word (Report Studio) report has been set as a default template.
- This procedure requires an active FLIR Tools+ license.

Follow this procedure:

1. On the *Library* tab, select the image or images that you want to include in your report.
2. Right-click the image or images and select *Create report*.

3. The *Select a Folder* dialog box is displayed. Select the folder to save the report in, enter a filename, and click *Save*.

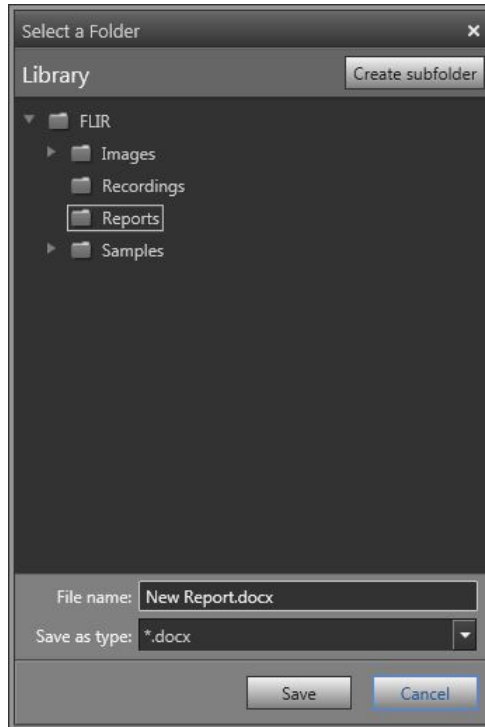

4. The *Report Properties* dialog box is displayed.

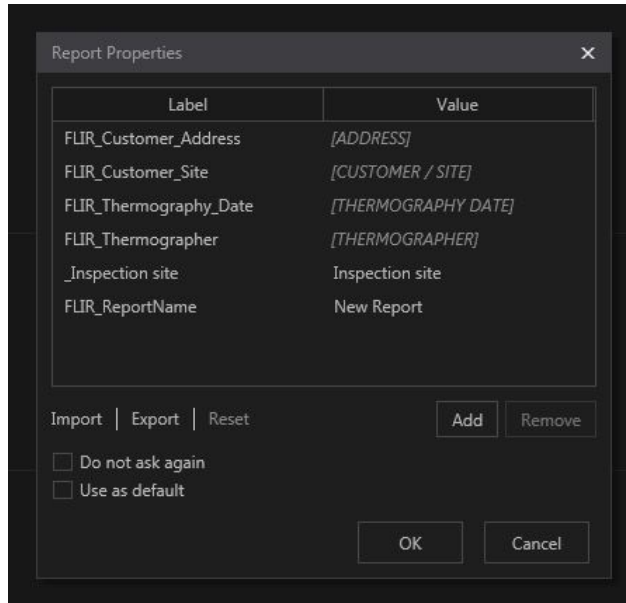

Do one or more of the following:

- Enter the customer information and information about the inspection in the predefined fields.
- Click *Import* to import properties from a previously saved text file.
- Click *Add* to add a new property.
- Select a property and click *Remove* to remove a property.
- Click *Export* to export the current property settings to a text file.

To create the report with the displayed properties, click *OK*.

5. The report opens as a Microsoft Word document. The selected image(s) and the information entered in the *Report Properties* dialog box populate the corresponding placeholders in the report.
6. Once the report is generated, advanced analysis can be carried out using the features in the FLIR Word Add-in. For more information, see sections 18.1 *Managing objects in the report*, page 57 and 19 *Analyzing and editing images using the FLIR Report Studio Image Editor*, page 77.

18.1 Managing objects in the report

18.1.1 General

A report template contains placeholders for objects such as thermal images, digital photos, tables, report properties, etc.

When you create a report based on a report template, these placeholders are automatically populated based on the images you choose to include in the report. You can also insert additional objects and modify their properties after you have launched the report in Microsoft Word, as described in the sections below.

When you create your own report templates, see section 20 *Creating report templates*, page 96, you insert objects and define their properties according to the sections below.

18.1.2 Inserting a thermal image object

A thermal image object is a placeholder that automatically loads a thermal image when a report is created.

Follow this procedure:

1. Place the pointer where you want the thermal image to appear in the report.
2. On the *FLIR* tab, click *Thermal Image*. This displays a thermal image placeholder on the page.



3. If you are modifying a report, you can open a thermal image in the placeholder. See section 18.1.8 *Replacing an image*, page 67.

If you are creating a report template, you can leave the placeholder as is, without opening any image.

18.1.3 Inserting a digital photo object

A digital photo object is a placeholder for the visual image associated with a thermal image.

Follow this procedure:

1. Place the pointer where you want the digital photo to appear in the report.
2. On the *FLIR* tab, click *Digital Photo*.

3. If there is more than one thermal image in the report, the *Choose Reference* dialog box is displayed. Click the thermal image that the digital photo you want to insert is associated with and click *OK*.

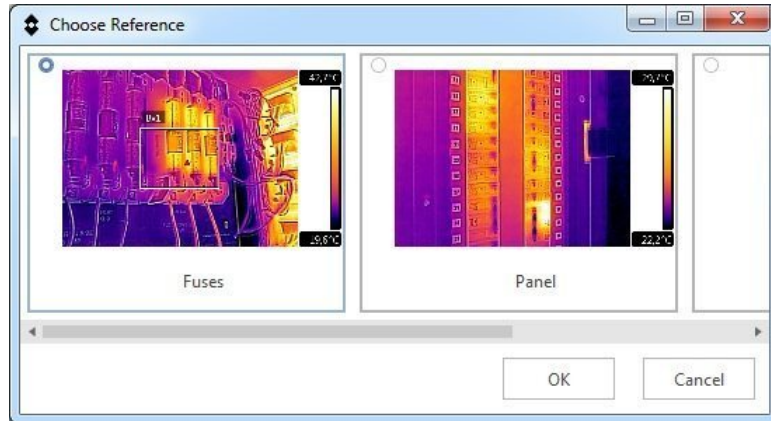

If there is only one thermal image in the report, the associated digital photo will be inserted automatically.

4. A digital photo placeholder is displayed on the page. The placeholder number refers to the associated thermal image.



18.1.4 Inserting a field object

18.1.4.1 General

A field object is a placeholder that automatically displays information associated with a thermal image when a report is created.

A field object consists of a label and a value, e.g., *Bx1 Average 42.3 °C*. You can choose to display only the value in the report, e.g., *42.3 °C*.

18.1.4.2 Procedure

Note This procedure assumes that you have previously inserted at least one thermal image in the report.

Follow this procedure:

1. Place the pointer where you want the field object to appear in the report.

Note Field objects will not work if you insert them in a text box. Only Microsoft Word fields work in text boxes. However, Field objects work in Microsoft Word tables.

2. On the *FLIR* tab, click *Field*.

3. If there is more than one image in the report, the *Choose Reference* dialog box is displayed. Click the image you want to use as the reference when populating the field object, and click *OK*.

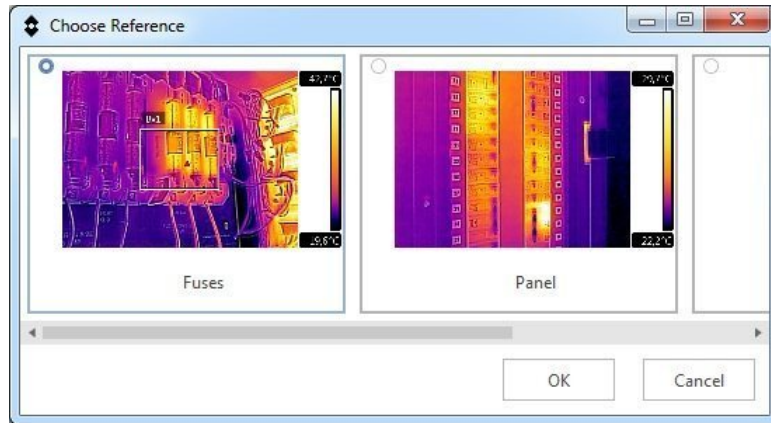

If there is only one image in the report, the field object will automatically be connected to that image.

4. The *Insert Field* dialog box is displayed.

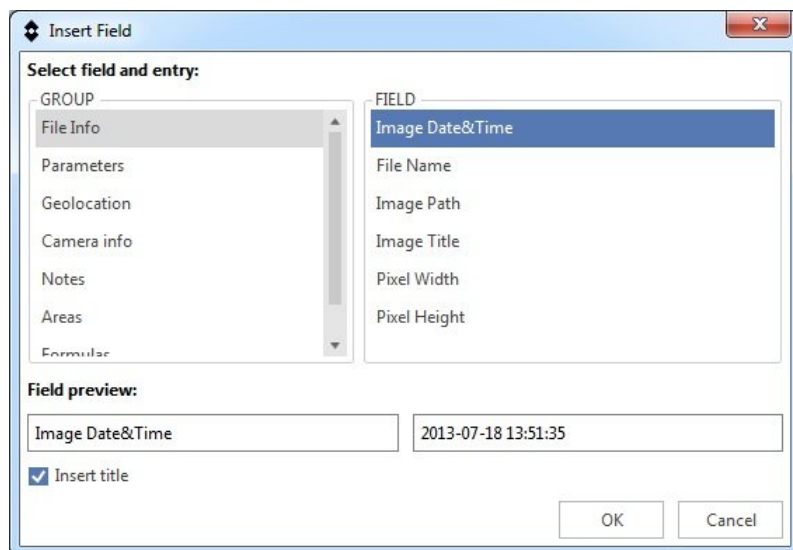

5. Use the *GROUP* and *FIELD* panes to select the content you want the field object to display. A preview of the field object (label and value) is displayed in the dialog box.
6. Do one of the following:
- Select the *Insert title* check box to display the label and the value in the report.
 - Clear the *Insert title* check box to display only the value in the report.
7. Click *OK*.
8. The field object with the content you have selected is displayed in the report.

Note If a field object is connected to a thermal image object and you delete either the field or the image, you will not be able to recreate the connection.

18.1.5 Inserting a table object

18.1.5.1 General

A table object is a placeholder that automatically displays a table with certain information associated with a thermal image when a report is created.

The following table objects are available:

- Measurements.
- Parameters.
- METERLiNK.
- Geolocation.
- Camera Info.
- File Info.
- Text Annotations.
- Notes.
- Formulas.
- Alarms.

In addition to the built-in table objects, you can create your own table objects. For more information, see section 18.1.5.3 *Creating a custom table object*, page 61.

You can also insert a summary table, including information about all thermal images in the report. For more information, see section 18.1.5.4 *Inserting a summary table*, page 64.

Note To insert a table object, you must first insert at least one thermal image.

18.1.5.2 *Inserting a table object*

Note This procedure assumes that you have previously inserted at least one thermal image in the report.

Follow this procedure:

1. Place the pointer where you want the table object to appear in the report.
2. On the *FLIR* tab, click *Table*.
3. If there is more than one image in the report, the *Choose Reference* dialog box is displayed. Click the image you want to use as the reference when populating the table object, and click *OK*.

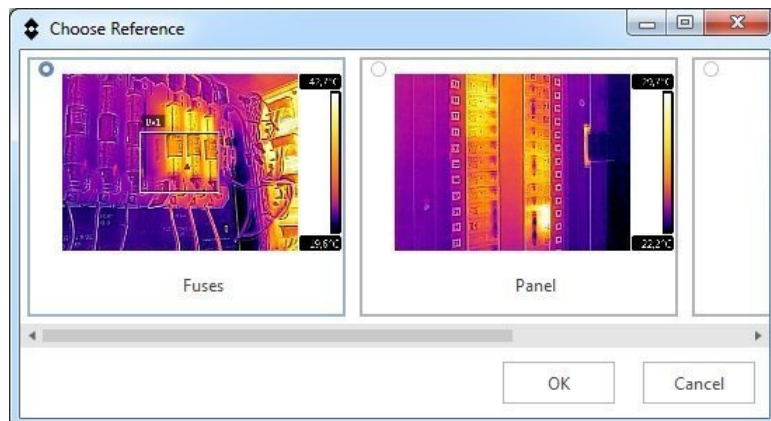

If there is only one image in the report, the table object will automatically be connected to that image.

4. The *Insert Table* dialog box is displayed.

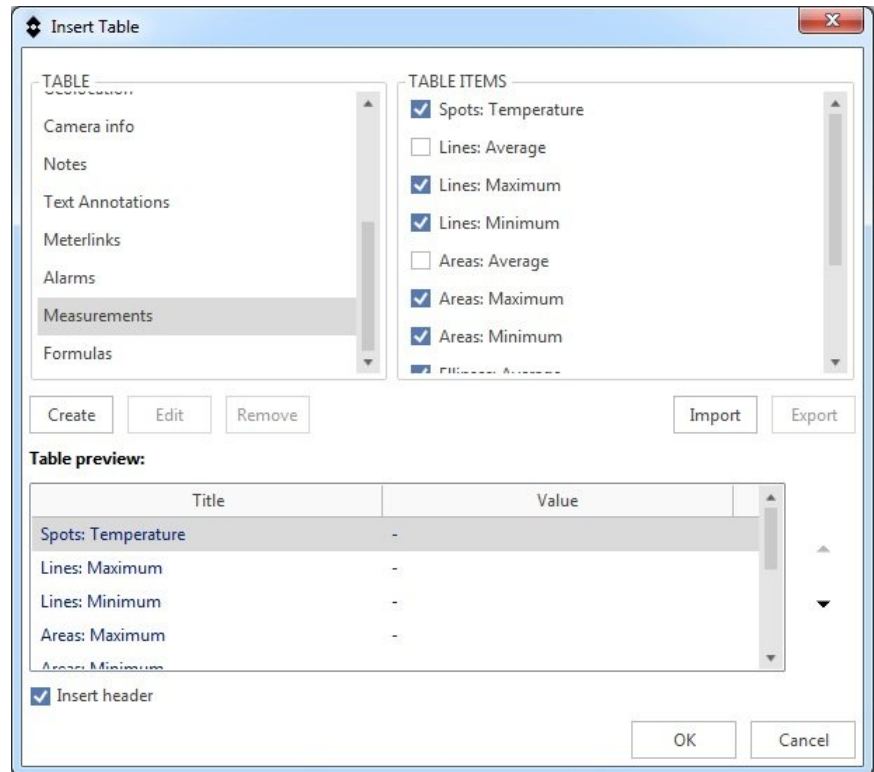

5. Use the *TABLE* and *TABLE ITEMS* panes to select the content you want the table object to display.

Note

- You can only insert table items from the same type of table. To create a table with table items from different tables, you must create a Custom table. For more information, see section 18.1.5.3 *Creating a custom table object*, page 61.
- To insert a formula table object, you must first create a formula. For more information, see section 18.3 *Working with formulas*, page 68.

6. A structural preview of the table is displayed in the dialog box. To change the order of the table items, click a row in the preview and then click the arrow button ▲ or ▼.

7. Do one of the following:

- Select the *Insert header* check box to display the table with a header in the report.
- Clear the *Insert header* check box to display the table without a header in the report.

8. Click *OK*.

9. The table object with the content you have selected is displayed in the report.

Note If a table object is connected to a thermal image object and you delete either the table or the image, you will not be able to recreate the connection.

18.1.5.3 *Creating a custom table object*

If the built-in table objects do not meet your needs, you can create your own table objects.

Note This procedure assumes that you have previously inserted at least one thermal image in the report.

Follow this procedure:

1. Place the pointer where you want the table object to appear in the report.

2. On the *FLIR* tab, click *Table*.
3. If there is more than one image in the report, the *Choose Reference* dialog box is displayed. Click the image you want to use as the reference when populating the table object, and click *OK*.

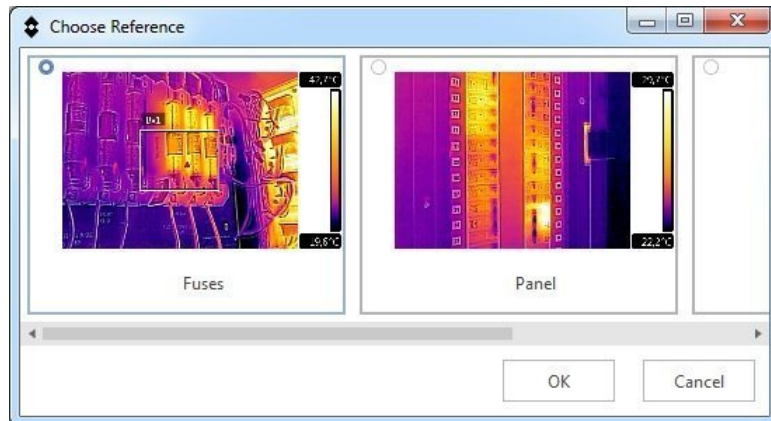

If there is only one image in the report, the table object will automatically be connected to that image.

4. The *Insert Table* dialog box is displayed.

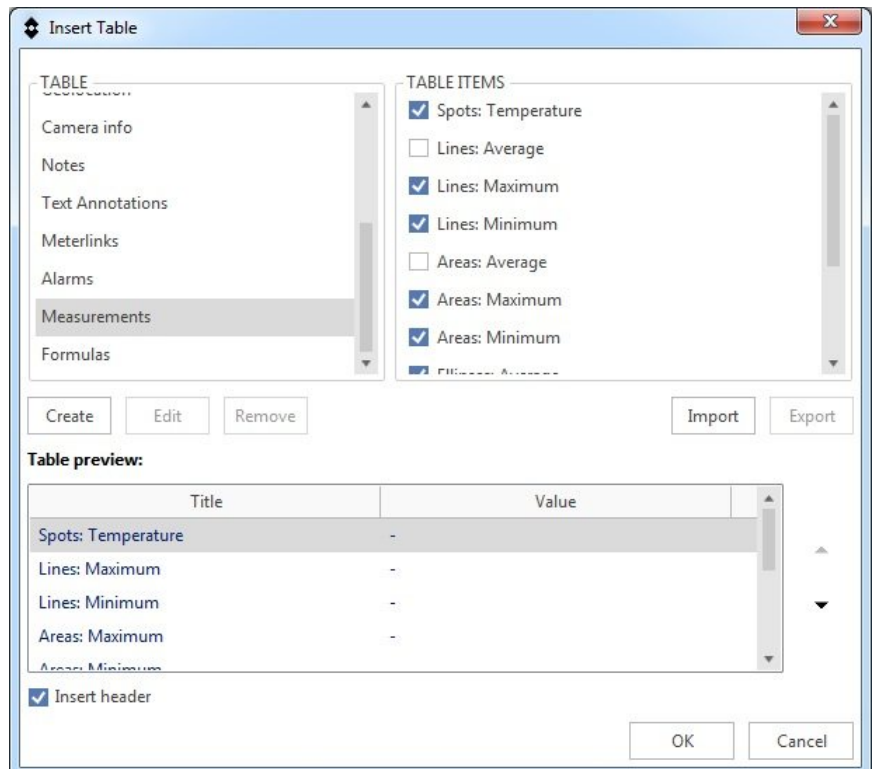

5. Click the *Create* button.

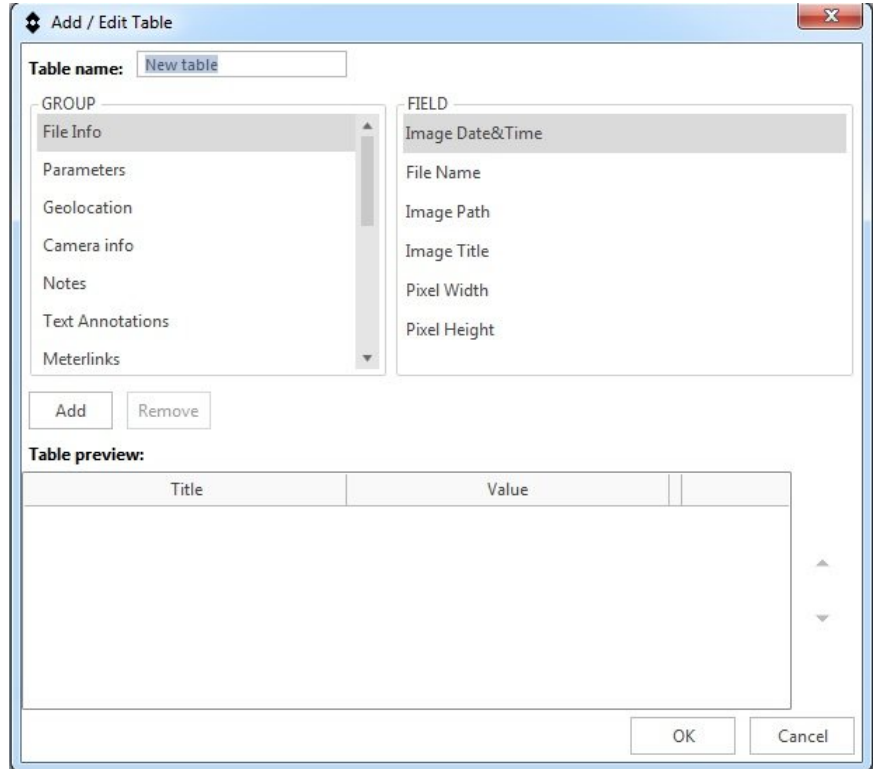

6. The *Add/EditTable* dialog box is displayed.



7. In the *Table name* text box, enter the name of your table.

8. Use the *GROUP* and *FIELD* panes to select the content you want to display. To include an item in the table, do one of the following:

- Click the item in the *FIELD* pane and then click the *Add* button.
- Double-click the item in the *FIELD* pane.
- Hover over the item in the *FIELD* pane and then click the displayed  button.

9. A structural preview of the table is displayed in the dialog box. To change the order of the table items, click a row in the preview and then click the arrow button  or .

10. To remove a table item, do one of the following:

- Click the row in the preview and then click the *Remove* button.
- Hover over the item in the preview and then click the displayed  button.

11. Click *OK*.

12. The *Insert Table* dialog box is displayed. In the *TABLE* pane, your table is displayed under *Custom*.

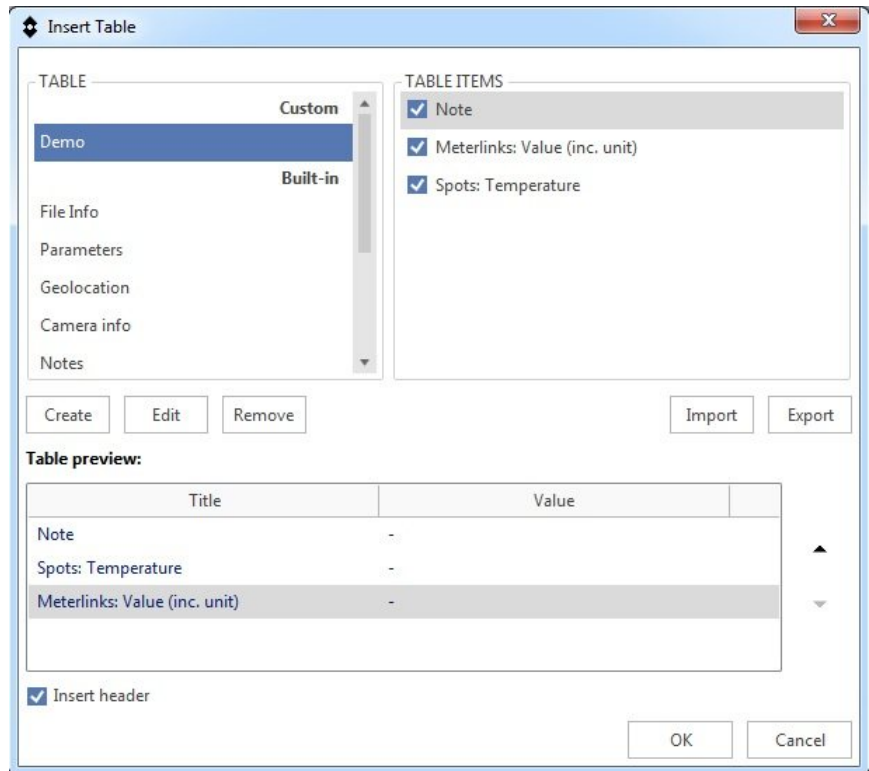

13. In the *Insert Table* dialog box, you can do the following:

- To edit a custom table, click the table in the *TABLE* pane and then click the *Edit* button.
- To delete a custom table, click the table in the *TABLE* pane and then click the *Remove* button.
- To import a custom table, click the *Import* button.
- To export a custom table, click the table in the *TABLE* pane and then click the *Export* button.

14. Do one of the following:

- Select the *Insert header* check box to display the table with a header in the report.
- Clear the *Insert header* check box to display the table without a header in the report.

15. Click *OK*.

16. The table object with the content you have selected is displayed in the report.

18.1.5.4 Inserting a summary table

A summary table object is a placeholder that automatically displays a table with certain information on all of the thermal images in the report.

Note

- In the summary table, you can only include fields that are available in the report as field objects or items in a table object.
- In a report template, a summary table can only be inserted into the *INTRO* or *FINAL* section (not into the *DATA* section).

Follow this procedure:

1. Place the pointer where you want the summary table to appear in the report.
2. On the *FLIR* tab, click the *Table* arrow. This displays a menu.

3. On the menu, click *Summary Table*.
4. The *Choose Summary Fields* dialog box is displayed.

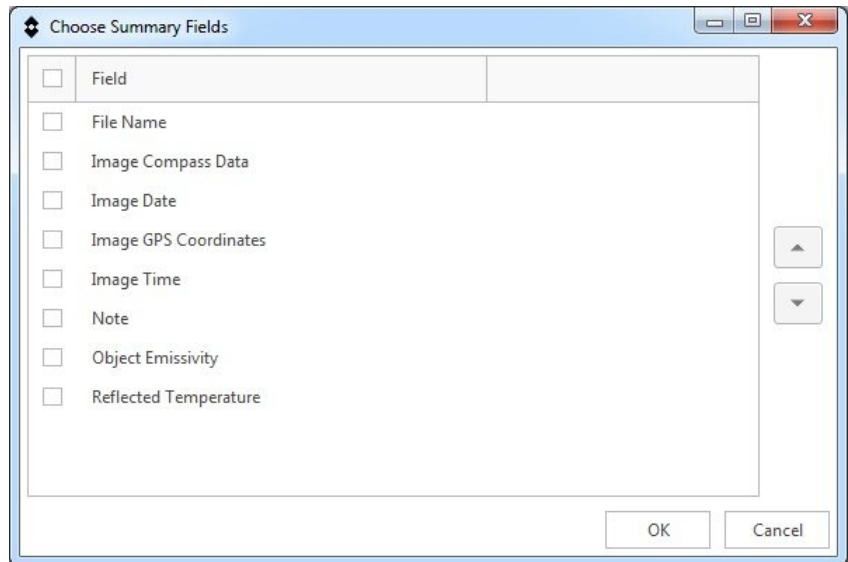

Note The displayed *Fields* are the ones that are available in the report as field objects or items in a table object.

5. Select the labels you want the summary table object to display.
6. Click *OK*.
7. The summary table object with the content you have selected is displayed in the report.

18.1.6 Inserting a report properties object

A report properties object is a placeholder that automatically displays customer information and information about the inspection when a report is created.

Note

- You can create and save a text file with report properties. Saved text files can be imported when creating a new report. For more information, see section 21.3 *Procedure*, page 101, step 10.
- See also section 18.4 *Document properties*, page 74.

Follow this procedure:

1. Place the pointer where you want the report properties object to appear in the report.
2. On the *FLIR* tab, click *Report Properties*.

3. The *Insert Report Properties* dialog box is displayed.

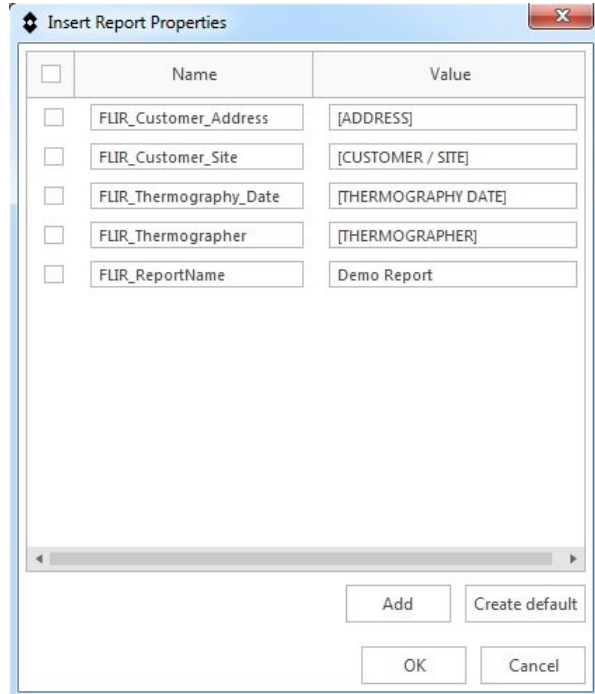

4. In the *Insert Report Properties* dialog box, you can do the following:

- To select the items you want the report properties object to display, use the check boxes.
- To change the item name, enter text in the *Name* text box.
- To change the item value, enter text in the *Value* text box.
- To add a new table item, click the *Add* button. Enter text in the *Name* and *Value* text boxes.
- To add default table items, click the *Create default* button.

5. Click *OK*.

6. A table with the content you have selected is displayed in the report.

7. You can edit the content of the report properties object using ordinary Microsoft Word features.

18.1.7 Resizing objects

18.1.7.1 Resizing an image object

Follow this procedure:

1. Click a thermal image or digital photo object on the report page.
2. Right-click the image object and select *Resize*.
3. To change the size of the image object, drag one of the handles.



18.1.7.2 Resizing a table object

Follow this procedure:

1. Select a table object on the report page.
2. On the *Table Tools* tab, click the *Layout* tab and use the controls to change the size of the table.

18.1.8 Replacing an image

You can replace an image in the report, while keeping all connections to other objects.

Follow this procedure:

1. Right-click an image object and select *Replace Image*.
2. In the *Open* dialog box, locate and open a new image.

18.1.9 Deleting objects

Note If a field or table object is connected to a thermal image object and you delete either of the objects, you will not be able to recreate the connection.

18.1.9.1 Deleting an image object

Follow this procedure:

1. Click an image object on the report page.
2. A label is displayed above the image. Click the label to select the entire image object.



3. Press the Delete key on your keyboard.

Note You can also delete an image object by right-clicking the image object and selecting *Delete Image*.

18.1.9.2 Deleting a field object

Follow this procedure:

1. Click a field object on the report page.
2. A label is displayed above the object. Click the label to select the entire object.



3. Press the Delete key on your keyboard.

18.1.9.3 Deleting a table object

Follow this procedure:

1. Click a table object on the report page.
2. On the Microsoft Word context-sensitive tab *Table Tools*, click the *Layout* tab and then click the *Delete* button. This displays a menu.
3. On the menu, click *Delete Table*.

18.2 Editing an image

You can edit thermal images directly from the report using the FLIR Report Studio Image Editor.

Note This procedure is applicable to editable Microsoft Word reports.

Follow this procedure:

1. To edit an image, do one of the following:
 - Click the image. On the *FLIR* tab, click *Image Editor*.
 - Right-click the image and select *Edit Image*.
 - Double-click the image.
2. This opens the FLIR Report Studio Image Editor. For more information, see section 19 *Analyzing and editing images using the FLIR Report Studio Image Editor*, page 77.

18.3 Working with formulas

18.3.1 General

The FLIR Word Add-in allows you to carry out advanced calculations on various items in the infrared image. A formula can contain all common mathematical operators and functions (+, -, ×, ÷, etc). Also, numerical constants such as π can be used.

Most importantly, references to measurement results, other formulas, and other numerical data can be inserted into formulas.

The formulas you create will be available in the FLIR Word Add-in and can be inserted in field and table objects in future reports.

Note

- A formula can operate only on a single infrared image: it cannot calculate, for example, differences between two infrared images.
- You can use any existing METERLiNK data in the infrared image as a value in a formula, in the same way as you would use an infrared measurement value. METERLiNK data can be stored in the infrared image by using an external FLIR/Extech meter—such as a clamp meter or a moisture meter—together with the infrared camera.

18.3.2 Creating a simple formula

Creating a formula that calculates the temperature difference between two spots

1. In your report, insert a thermal image object, see section 18.1.2 *Inserting a thermal image object*, page 57.
2. Open an image in the Image Editor, see section 18.2 *Editing an image*, page 68.
3. Add two spot tools in the image, see section 19.5.2 *Adding a measurement tool*, page 80.
4. On the *FLIR* tab, click *Formula manager*.

5. The *Formula manager* dialog box is displayed. Click the *Create* button.

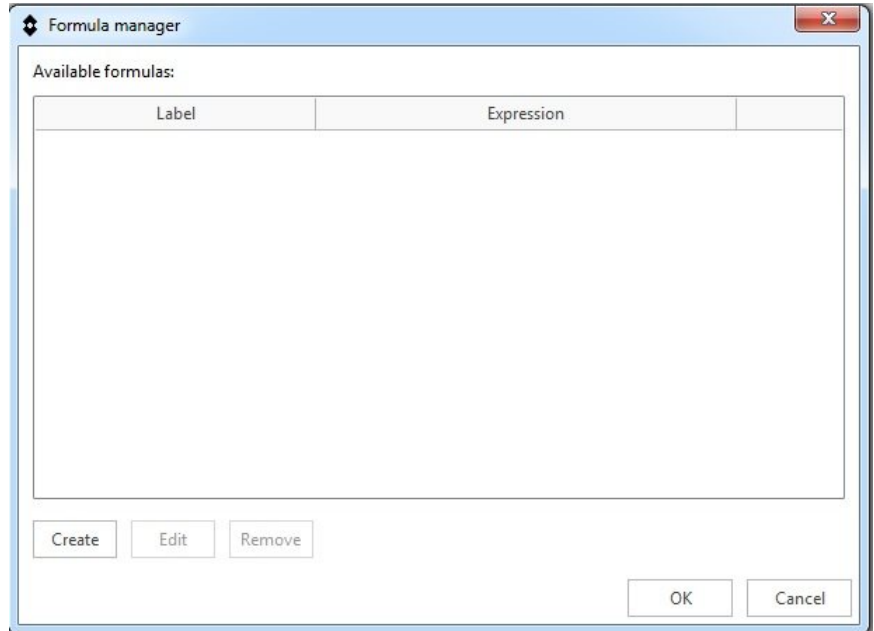

6. The *Create formula* dialog box is displayed. Click the *field* button.

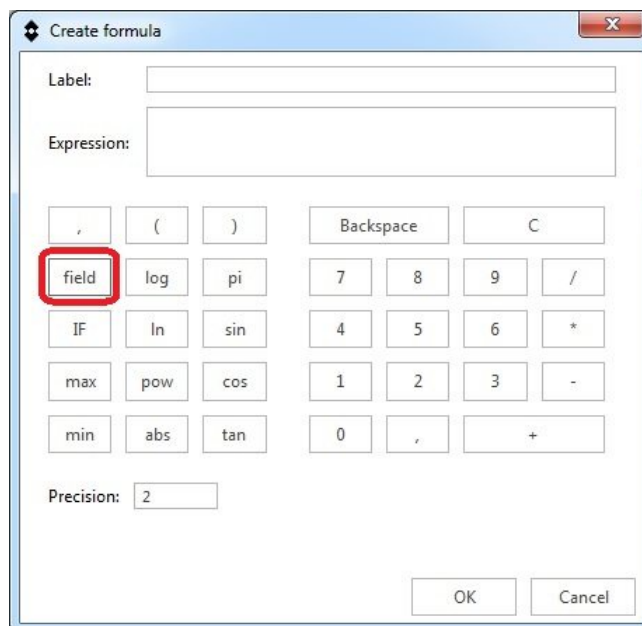

7. The *Select field and entry* dialog box is displayed.

Do the following:

- 7.1. In the *GROUP* pane, click *Spotmeters*.
- 7.2. In the *ENTRY* pane, click *Sp2*.
- 7.3. In the *FIELD* pane, click *Temperature*.
- 7.4. Click *OK*.

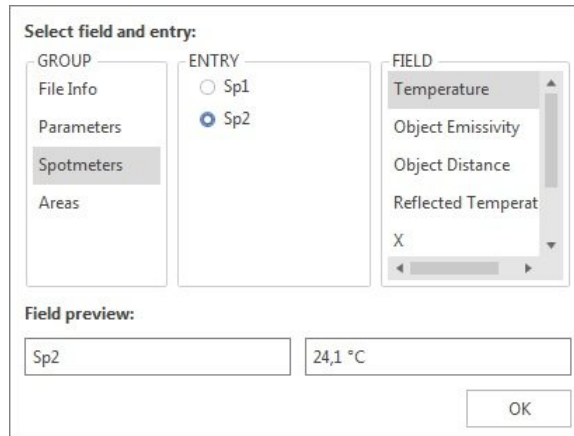

8. In the *Create formula* dialog box, click the minus button to add a subtraction mathematical operator.
9. Click the *field* button. Repeat step 7 for spot *Sp1*.
10. The *Create formula* dialog box now displays the temperature difference formula using FLIR Systems syntax.

In the *Label* text box, enter the text you want to be displayed with the formula result in the report. In the *Precision* box, enter the number of decimal places for the formula result.

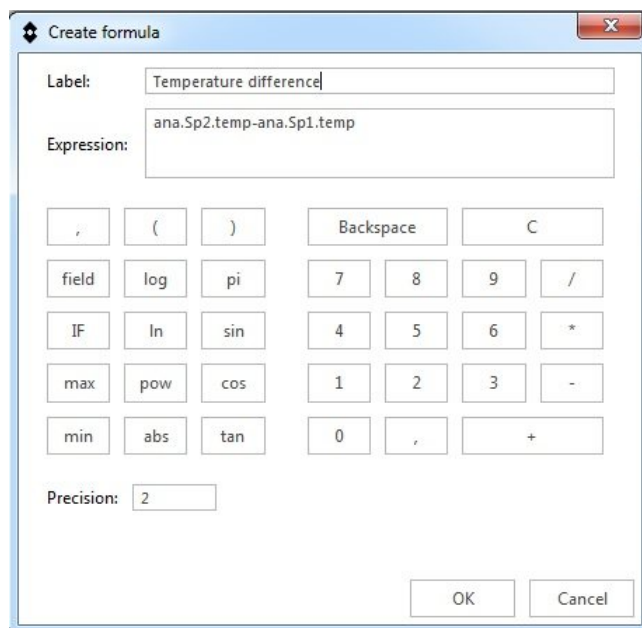

11. In the *Create formula* dialog box, click *OK*.
12. In the *Formula manager* dialog box, click *OK*.
13. The created temperature difference formula can now be inserted in the field and table objects in the report.

18.3.3 Creating a conditional formula

For some applications, you may, for example, want to display the result of a calculation in a green font color if the result is lower than a critical value, and in a red font color if the result is higher than the critical value. You do this by creating a conditional formula using the *IF* statement.

The procedure below describes how you set up a conditional formula that displays the result from a temperature difference formula in red if the value is higher than 2.0 degrees, and in green if the value is lower than 2.0 degrees.

Creating a conditional formula using the IF statement

1. Create a formula that calculates the temperature difference between two spots, see section 18.3.2 *Creating a simple formula*, page 68.
2. On the *FLIR* tab, click *Formula manager*.
3. If there is more than one image in the report, the *Choose Reference* dialog box is displayed. Click an image and then click *OK*.
4. The *Formula manager* dialog box is displayed. Click the *Create* button.

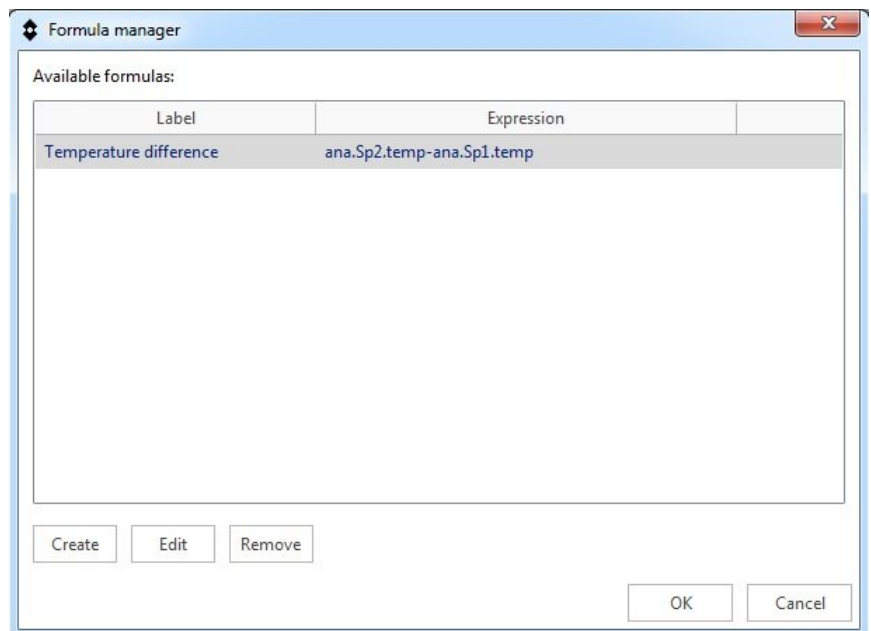

5. The *Create formula* dialog box is displayed. Click the *IF* button.

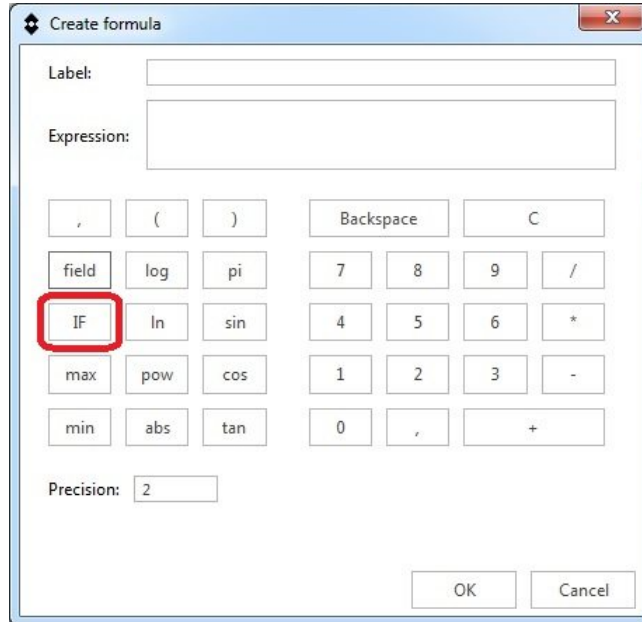

6. The *Create 'IF' formula* dialog box is displayed. Click the *Add...* button.

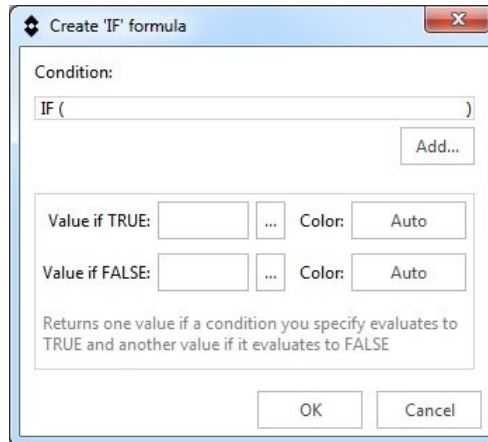

7. A dialog box is displayed.

Do the following:

- 7.1. Under *Left value*, click the ... button. This displays the *Select field and entry* dialog box. In the *GROUP* pane, click *Formulas*. In the *FIELD* pane, select the temperature difference formula. Click *OK*.
- 7.2. In the *Operator* drop-down list, select *>*.
- 7.3. In the *Right value* text box, enter *2.0*.
- 7.4. Click *OK*.



8. In the *Create 'IF' formula* dialog box, do the following:

- 8.1. On the *Value if TRUE* row, click the ... button and select the temperature difference formula.
- 8.2. On the *Value if TRUE* row, click the *Auto* button and select the color red.
- 8.3. On the *Value if FALSE* row, click the ... button and select the temperature difference formula.
- 8.4. On the *Value if FALSE* row, click the *Auto* button and select the color green.
- 8.5. Click *OK*.

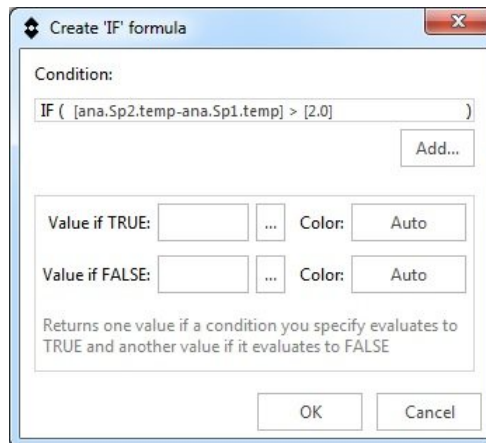

9. The *Create formula* dialog box now displays the complete conditional formula. The two 10-digit code strings after the equals sign represent the colors.

In the *Label* text box, enter the text you want to be displayed with the formula result in the report. In the *Precision* box, enter the number of decimal places for the formula result.

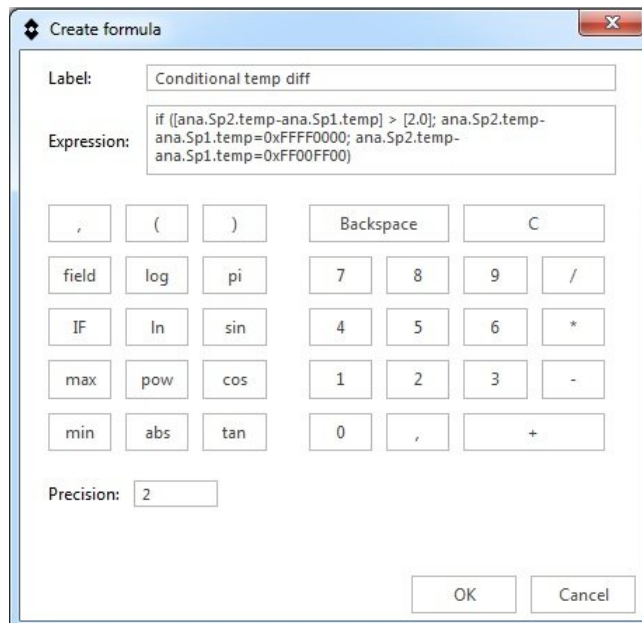

10. In the *Create formula* dialog box, click *OK*.

11. In the *Formula manager* dialog box, click *OK*.

12. The created conditional formula can now be inserted in the field and table objects in the report. The result of the temperature difference formula will be displayed in red or green, depending on the measured values of the two spotmeters.

18.4 Document properties

18.4.1 General

When creating an infrared report, the FLIR program extracts the Microsoft Word document properties for the report template and inserts these properties into corresponding Microsoft Word fields in the final report.

You can use these document properties to automate several time-consuming tasks when creating a report. For example, you may want to automatically add information such as the name, address, and e-mail address of the inspection site, the model name of the camera that you are using, and your e-mail address.

See also section 18.1.6 *Inserting a report properties object*, page 65.

18.4.2 Types of document properties

There are two different types of document properties:

- Summary document properties.
- Custom document properties.

For the former, you can only change the values, but for the latter you can change both the labels and the values.

18.4.3 Creating and editing Microsoft Word document properties

Creating and editing document properties

1. Start the FLIR Report Studio wizard. In the center pane, right-click one of the report templates and select *Edit*. This opens the report template (*.dotx) in Microsoft Word.
2. On the *File* tab, click *Info*.
3. From the *Properties* drop-down menu, select *Advanced Properties*.
4. On the *Summary* tab, enter your information in the appropriate text boxes.
5. Click the *Custom* tab.
6. To add a custom property, type a name in the *Name* box. To make your custom properties easy to find, you can type an underscore (_) as the first character in the name of the property.
7. Use the *Type* box to specify the type of property.
8. To specify the value of the property, type it in the *Value* box.
9. Click *Add* to add the custom property to the list of properties, and then click *OK*.
10. Save the infrared report template using a different filename but with the same filename extension (*.dotx). You have now added summary and custom properties to your renamed infrared report template.

Note

- If you want to change the name of a custom document property, due to how the *Custom* tab of the *Properties* dialog box in Microsoft Word works, the only way to do this is to delete it and then recreate it. If you want to move a document property up or down, the entire list has to be recreated.
- A Microsoft Word field is not the same as a field inserted by clicking the *Field* button on the *FLIR* tab.
- You may find that a FLIR Systems property has been added to your document automatically. Do not remove this property. The FLIR program uses it to distinguish between infrared documents and other documents.

18.5 Creating a report

You can easily and efficiently create an infrared report using the FLIR Report Studio wizard.

Follow this procedure:

1. On the *FLIR* tab, click *New Report*.

2. This opens the FLIR Report Studio wizard. For more information, see section 21 *Creating reports using the FLIR Report Studio wizard*, page 101.

18.6 Exporting a report

Before you send the infrared report to your client, you can export it in one of the following formats:

- **Flat DocX:** This exports the report as a flat report with the suffix “_flat”. A flat report can still be edited using ordinary Microsoft Word features, but it is no longer possible to manage the image, field, and table objects.
- **PDF:** This exports the report as a non-editable PDF report.

Follow this procedure:

1. On the *FLIR* tab, in the *Export* group, click the arrow. This displays a menu.
2. On the menu, select *Flat DocX* or *PDF*.

18.7 Creating a report template

You can create your own report templates using the FLIR Report Studio Template Editor.

Follow this procedure:

1. On the *FLIR* tab, click *Create new template*.
2. This opens the FLIR Report Studio Template Editor. For more information, see section 20 *Creating report templates*, page 96.

18.8 Changing the settings

You can change the settings for the temperature and distance units.

Note A change of settings will apply to new objects that are inserted in the report, but existing objects will keep the previous settings. A change of settings in a report template will be applied to all objects when a report is generated based on the template.

Follow this procedure:

1. On the *FLIR* tab, click *Settings*. This displays a menu.
2. On the menu, click *Set units*. This displays a dialog box, where you can set the temperature and distance units. If a unit has not been specified in the report template, *default* or *not set* is marked.

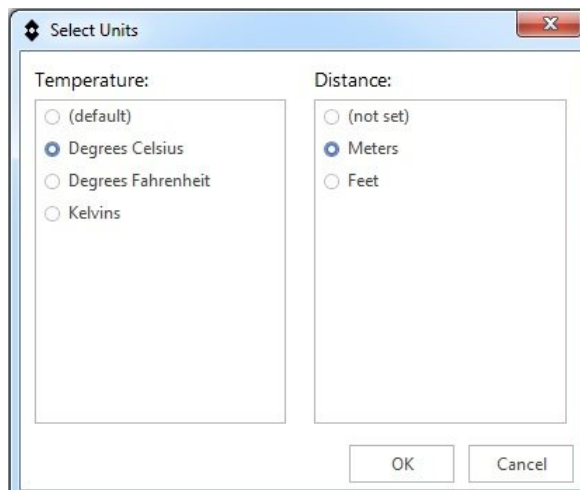

18.9 Help menu

The *Help* menu includes links to support and training sources, license information, check for updates, etc.

The *Help* menu is available on the *FLIR* tab under *Settings*.

Analyzing and editing images using the FLIR Report Studio Image Editor

19.1 General

The FLIR Report Studio Image Editor is a powerful tool for analyzing and editing infrared images.

These are some of the functions and settings you can experiment with:

- Adding measurement tools.
- Adjusting the infrared image.
- Changing the color distribution.
- Changing the color palette.
- Changing the image modes.
- Working with color alarms and isotherms.
- Changing the measurement parameters.

19.2 Starting the Image Editor

You can start the Image Editor from an editable (radiometric) infrared report using the FLIR Word Add-in.

You can also start the Image Editor from the FLIR Report Studio wizard.

19.2.1 Starting the Image Editor from the FLIR Word Add-in

You can start the Image Editor from an editable infrared report..

Follow this procedure:

1. Do one of the following:
 - Double-click an image in the report.
 - Select an image and click *Image Editor* on the *FLIR* tab.
 - Right-click an image and select *Edit Image*.

19.2.2 Starting the Image Editor from the FLIR Report Studio wizard

Follow this procedure:

1. Do one of the following:
 - In the center pane, double-click an image.
 - In the right pane, double-click an image.

Note

- If you edit an image from the center pane, the original image will be changed.
- If you edit an image from the right pane, only the image in the report will be changed.

19.3 Image Editor screen elements

19.3.1 Figure

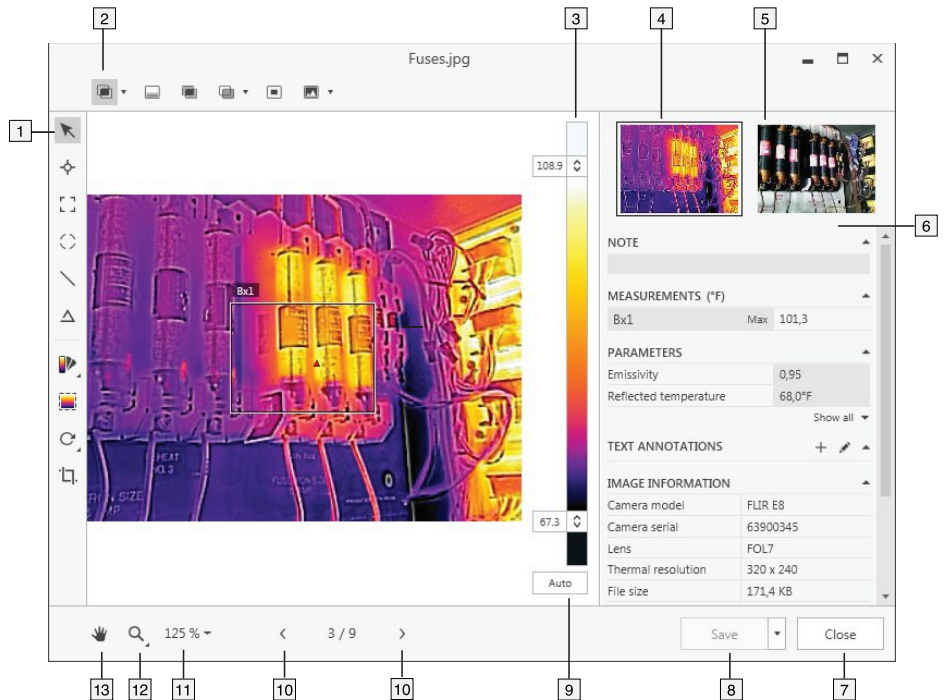

19.3.2 Explanation

1. Measurement toolbar.
2. Image mode toolbar.
3. Temperature scale.
4. Thumbnail view of the infrared image.
5. Thumbnail view of the digital photo (if available).
6. Results and information pane:
 - Note.
 - Measurements.
 - Parameters.
 - Annotations.
 - Image information.
7. Close button.
8. Save button.
9. Auto-adjust button.
10. Navigation buttons. Click the buttons to go to the previous/next image.
11. Zoom setting button. Click the button and select one of the predefined zoom settings.
12. Zoom button. Click the button to display the zoom-in and zoom-out buttons.
13. Pan button. Click the button and then drag the image to pan a zoomed-in image.



Note A  icon in the result table indicates that the measurement result is above or below the calibrated temperature range of the infrared camera and is therefore incorrect. This phenomenon is called *overflow* or *underflow*.

A  icon in the result table indicates that the measurement result is too close to the calibrated temperature range of the infrared camera and is therefore unreliable.

19.4 Basic image editing functions

19.4.1 Rotating the image

Follow this procedure:

1. On the measurement toolbar, select  (*Rotate image and measurements*). This displays a toolbar.
2. On the toolbar, do one of the following:
 - Click  to rotate the image counter-clockwise.
 - Click  to rotate the image clockwise.



19.4.2 Cropping the image

You can crop an image and save the cropped image as a copy of the original image.

Note

Cropping is possible when you start the Image Editor from an image in the center pane of the FLIR Report Studio wizard.

Follow this procedure:

1. On the measurement toolbar, select  (*Crop*). This displays a box on the image.
2. Select the crop region by moving and adjusting the size of the box.
3. In the crop region box, do one of the following:
 - Click  to crop the image. This opens the *Save as* dialog box.
 - Click  to cancel the crop action.

19.5 Working with measurement tools

19.5.1 General

To measure a temperature, you can use one or more measurement tools, e.g., a spot, box, circle, or line.

When you add a measurement tool to the image, the measured temperature will be displayed in the right pane of the Image Editor. The tool setup will also be saved to the image file and the measured temperature will be available for display in your infrared report.





Note A  icon in the result table indicates that the measurement result is above or below the calibrated temperature range of the infrared camera and is therefore incorrect. This phenomenon is called *overflow* or *underflow*.

A  icon in the result table indicates that the measurement result is too close to the calibrated temperature range of the infrared camera and is therefore unreliable.

19.5.2 Adding a measurement tool

Follow this procedure:

1. On the measurement toolbar, select one of the following:

- Select  (Add spot) to add a spot.
- Select  (Add box) to add a box.
- Select  (Add ellipse) to add a ellipse.
- Select  (Add line) to add a line.

2. Click the location on the image where the measurement tool is to be placed.

19.5.3 Moving and resizing a measurement tool

Follow this procedure:

1. On the measurement toolbar, select  (Selection).
2. To move a measurement tool, select the tool on the image and drag it to a new position.
3. To resize a measurement tool, select the tool on the image and use the selection tool to drag the handles that are displayed around the frame of the tool.

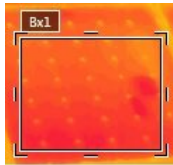

19.5.4 Creating local markers for a measurement tool

19.5.4.1 General

The Image Editor will respect any existing markers for a measurement tool as set up in the camera. However, sometimes you may want to add a marker when analyzing the image. You do this by using local markers.

19.5.4.2 Procedure

Follow this procedure:

1. On the measurement toolbar, select  (Selection).
2. Right-click the tool and select *Local max/min/avg markers*.
3. In the dialog box, select or clear the markers you want to add or remove.
4. Click *OK*.

19.5.5 Calculating areas

19.5.5.1 General

The distance included in the image parameter data can be used as the basis for area calculations. A typical application is to estimate the size of a damp stain on a wall.

To calculate the area of a surface, you need to add a box or circle measurement tool to the image. The Image Editor calculates the area of the surface enclosed by the box or circle tool. The calculation is an estimate of the surface area, based on the distance value.

19.5.5.1.1 Procedure

Follow this procedure:

1. Add a box or circle measurement tool, see section 19.5.2 *Adding a measurement tool*, page 80.
2. Adjust the size of the box or circle tool to the size of the object, see section 19.5.3 *Moving and resizing a measurement tool*, page 80.
3. Right-click the tool and select *Local max/min/avg markers*. In the dialog box, select the *Area* check box. This displays the calculated area, based on the distance value, in the *MEASUREMENTS* pane.
4. To change the distance value, click the value field in the *PARAMETERS* pane, type a new value and press Enter. The recalculated area, based on the new distance value, is displayed in the *MEASUREMENTS* pane.

19.5.5.1.2 Calculating lengths

19.5.5.1.2.1 General

The distance included in the image parameter data can be used as the basis for length calculations.

To calculate the length, you need to add a line measurement tool to the image. The Image Editor calculates an estimate of the line length, based on the distance value.

19.5.5.1.2.1.2 Procedure

Follow this procedure:

1. Add a line measurement tool, see section 19.5.2 *Adding a measurement tool*, page 80.
2. Adjust the size of the line tool to the size of the object, see section 19.5.3 *Moving and resizing a measurement tool*, page 80.
3. Right-click the tool and select *Local max/min/avg markers*. In the dialog box, select the *Length* check box. This displays the calculated length, based on the distance value, in the *MEASUREMENTS* pane.
4. To change the distance value, click the value field in the *PARAMETERS* pane, type a new value and press Enter. The recalculated area, based on the new distance value, is displayed in the *MEASUREMENTS* pane.

19.5.6 Setting up a difference calculation

19.5.6.1 General

A difference calculation gives the difference (delta) between two temperatures—for example, two spots, or a spot and the maximum temperature in the image.

19.5.6.2 Procedure

Note This procedure assumes that you have previously added at least one measurement tool to the image.

19.5.6.2.1 Procedure

Follow this procedure:

1. On the measurement toolbar, select  (*Add delta*).
2. The difference calculation is displayed under *MEASUREMENTS* in the right pane.



3. To change the setup for the difference calculation, do the following:

- 3.1. In the right pane, click  (*Edit*). This displays a dialog box.
- 3.2. In the dialog box, select the measurement tools and what values (maximum, minimum, or average) you want to use in the difference calculation. You can also select a fixed-temperature reference.

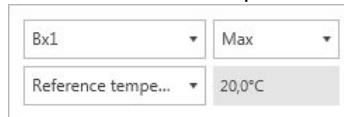

4. To delete the difference calculation, click  (*Delete*).

19.5.7 Deleting a measurement tool

Follow this procedure:

1. On the measurement toolbar, select  (*Selection*).
2. Select the measurement tool on the image and do one of the following:
 - Press the Delete key on your keyboard.
 - Right-click the tool and select *Delete*.

Note Deleting a measurement tool included in a difference calculation also deletes the difference calculation.

19.6 Adjusting the infrared image

19.6.1 General

An infrared image can be adjusted manually or automatically.

In the Image Editor, you can manually change the top and bottom levels in the temperature scale. This makes it easier to analyze the image. You can, for example, change the temperature scale to values close to the temperature of a specific object in the image. This will make it possible to detect anomalies and smaller temperature differences in the part of the image of interest.

When auto-adjusting an image, the Image Editor adjusts the image for the best image brightness and contrast. This means that the color information is distributed over the existing temperatures of the image.

In some situations, the image may contain very hot or cold areas outside your area of interest. In such cases you will want to exclude those areas when auto-adjusting the image and use the color information only for the temperatures in your area of interest. You can do so by defining an auto-adjust region.

19.6.2 Example 1

Here are two infrared images of a building. In the left image, which is auto-adjusted, the large temperature span between the clear sky and the heated building makes a correct analysis difficult. You can analyze the building in more detail if you change the temperature scale to values close to the temperature of the building.

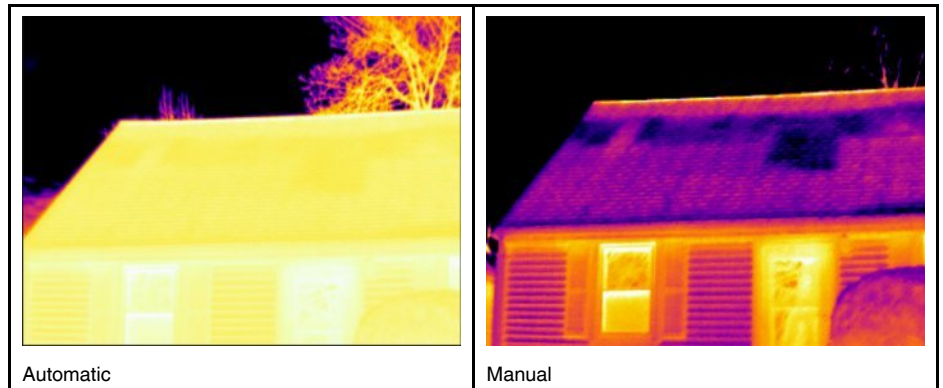

19.6.3 Example 2

Here are two infrared images of an isolator in a power line. To make it easier to analyze the temperature variations in the isolator, the temperature scale in the right image has been changed to values close to the temperature of the isolator.

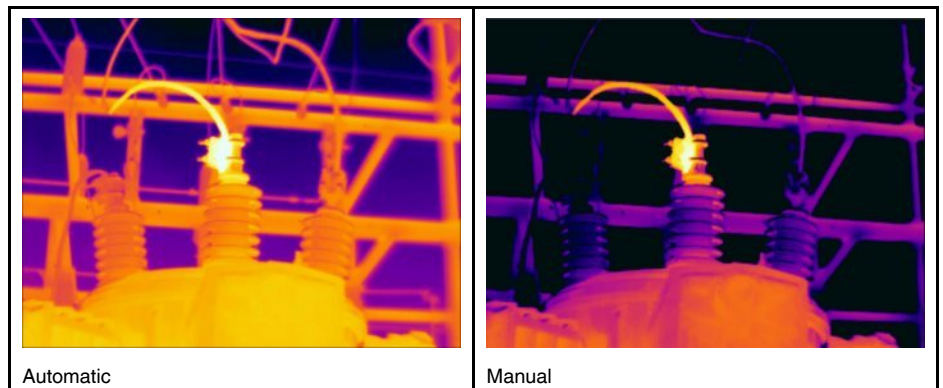

19.6.4 Changing the temperature levels

Follow this procedure:

1. To change the top level in the temperature scale, drag the top slider up or down.
2. To change the bottom level in the temperature scale, drag the bottom slider up or down.



19.6.5 Auto-adjusting the image

Follow this procedure:

1. To auto-adjust the image, click *Auto*.

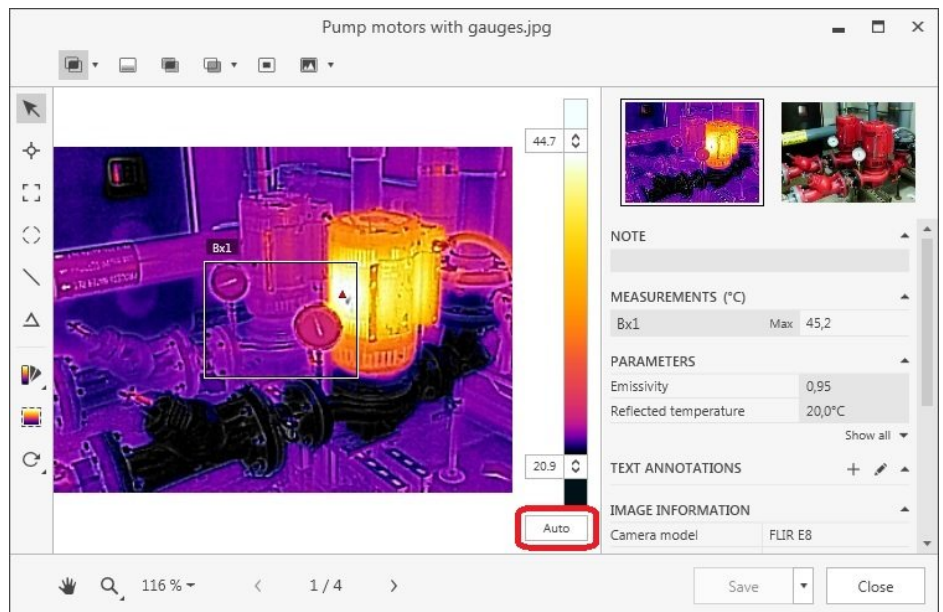

19.6.6 Defining an auto-adjust region

An auto-adjust region sets the top and bottom levels in the temperature scale to the maximum and minimum temperatures in that area. By using the color information only for the relevant temperatures, you will get more details in your area of interest.

Follow this procedure:

1. On the measurement toolbar, select  (*Set auto adjust region*).

- Use the displayed tool to create a region. This region can be moved and resized to suit your area of interest.

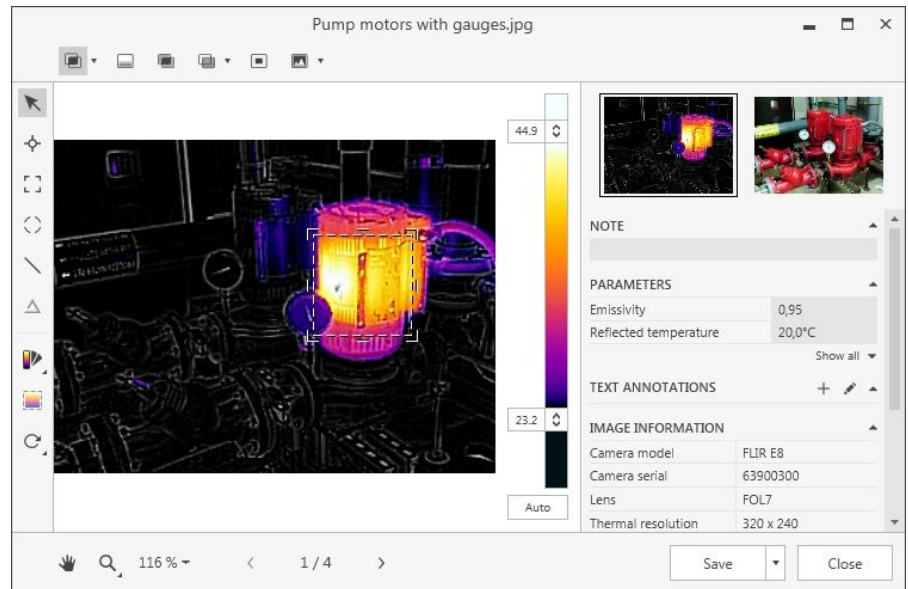

- To delete the auto-adjust area, select the region and do one of the following:
 - Press the Delete key on your keyboard.
 - Right-click the region and select *Delete*.

19.7 Changing the color distribution

19.7.1 General

You can change the distribution of colors in an image. A different color distribution can make it easier to analyze the image more thoroughly.

19.7.2 Definitions

You can choose from the following color distributions:

- Temperature Linear:** This is an image-displaying method where the color information in the image is distributed linearly to the temperature values of the pixels.
- Histogram Equalization:** This is an image-displaying method that distributes the color information over the existing temperatures of the image. This method of distributing the information can be particularly successful when the image contains few peaks at very high temperature values.
- Signal Linear:** This is an image-displaying method where the color information in the image is distributed linearly to the signal values of the pixels.
- Digital Detail Enhancement:** This is an image-displaying method where high-frequency content in the image, such as edges and corners, are enhanced to increase the visibility of details.

19.7.3 Procedure



Follow this procedure:



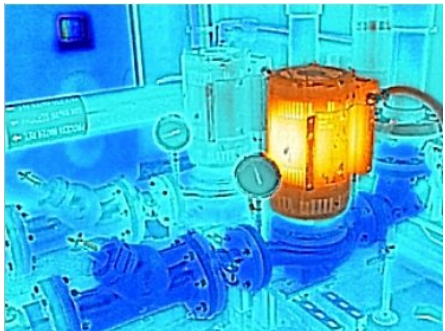
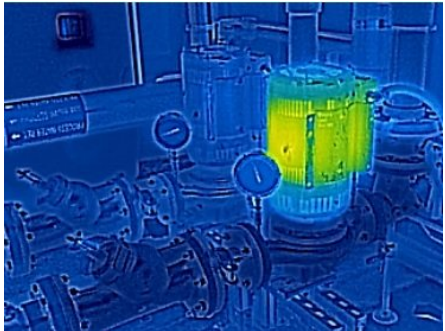
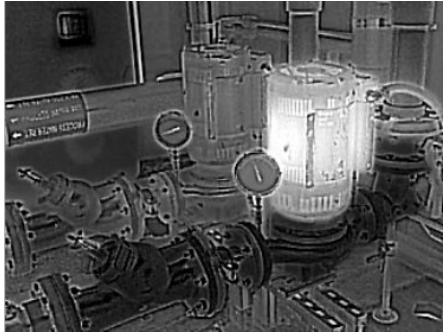

- Right-click the image and select *Color distribution*. This displays a menu.
- On the menu, select one of the following:
 - Temperature Linear*.
 - Histogram Equalization*.
 - Signal Linear*.
 - Digital Detail Enhancement*.

19.8 Changing the color palette

19.8.1 General

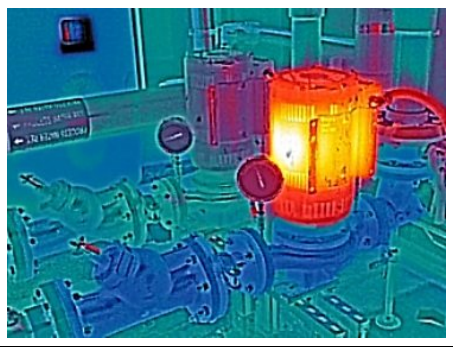
You can change the palette that is used to display the different temperatures within an image. A different palette can make it easier to analyze the image.

Color palette	Image example
<i>Artic</i>	
<i>Cool</i>	
<i>Gray</i>	
<i>Iron</i>	

Color palette	Image example
<i>Lava</i>	
<i>Rainbow</i>	
<i>Rainbow HC</i>	
<i>Warm</i>	

19.8.2 Procedure

Follow this procedure:

1. On the measurement toolbar, select  (*Color*). This displays a menu.
2. On the menu, click the palette you want to use.

19.9 Changing the image modes

19.9.1 General

For some images you can change the image mode.

19.9.2 Types of image modes

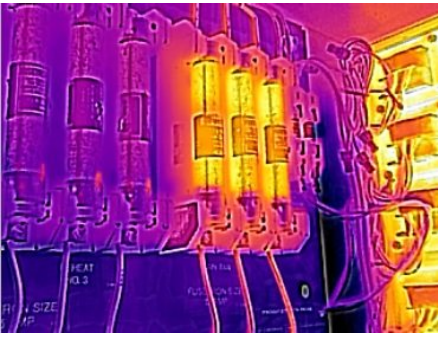
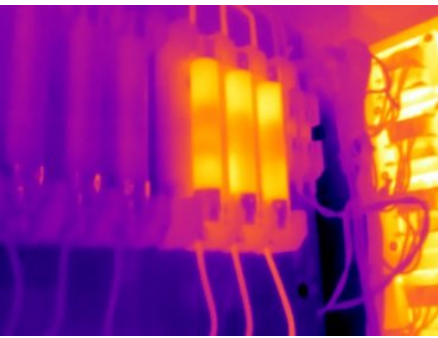
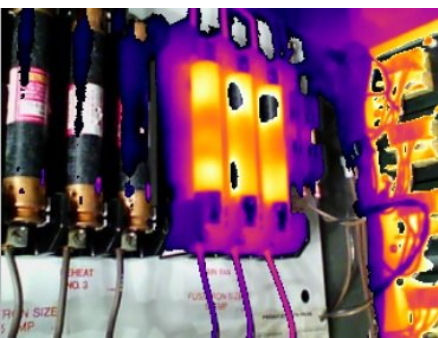

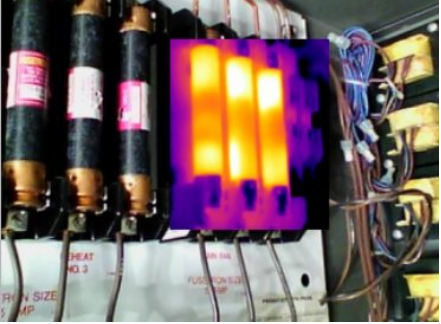







Image mode	Image example
<p><i>Thermal MSX</i> (Multi Spectral Dynamic Imaging): This mode displays an infrared image where the edges of the objects are enhanced. The thermal/photo balance can be adjusted.</p>	
<p><i>Thermal</i>: This mode displays a fully infrared image.</p>	
<p><i>Thermal Fusion</i>: This mode displays a digital photo where some parts are displayed in infrared, depending on the temperature limits.</p>	
<p><i>Thermal Blending</i>: The camera displays a blended image that uses a mix of infrared pixels and digital photo pixels. The thermal/photo balance can be adjusted.</p>	

Image mode	Image example
<p><i>Picture in picture</i>: This mode displays an infrared image frame on top of a digital photo.</p>	
<p><i>Digital camera</i>: This mode displays a fully digital photo.</p>	

19.9.3 Procedure

Follow this procedure:

1. On the image mode toolbar, select one of the following:

-  (Thermal MSX).
-  (Thermal).
-  (Thermal Fusion).
-  (Thermal Blending).
-  (Picture in picture).
-  (Digital camera).

2. Applicable to the *Thermal MSX* and *Thermal Blending* modes: To adjust the thermal/photo balance, click the arrow next to the image mode icon and drag the slider left or right.

3. Applicable to the *Digital camera* mode: To change the image to grayscale, click the arrow next to the image mode icon and select the check box.

Note The grayscale setting for the digital camera remains when switching to other image modes that use the visual image, e.g., *Thermal Fusion*, *Thermal Blending*, and *Picture in picture*.

19.10 Working with color alarms and isotherms

19.10.1 General

By using color alarms (isotherms), anomalies can easily be discovered in an infrared image. The isotherm command applies a contrasting color to all pixels with a temperature

above, below, or between the set temperature levels. There are also alarm types that are specific to the building trade: humidity and insulation alarms.

You can select the following types of color alarms:

- *Above alarm*: This will apply a contrasting color to all pixels with a temperature above the specified temperature level.
- *Below alarm*: This will apply a contrasting color to all pixels with a temperature below the specified temperature level.
- *Interval alarm*: This will apply a contrasting color to all pixels with a temperature between two specified temperature levels.
- *Humidity alarm*: Triggers when a surface where the relative humidity exceeds a preset value is detected.
- *Insulation alarm*: Triggers when there is an insulation deficiency in a wall.
- *Custom alarm*: This alarm type allows you to manually modify the settings for a standard alarm.

Setting parameters for the activated color alarm are displayed under *ALARM* in the right pane.

ALARM (INTERVAL)	
Upper limit	37,6°C
Lower limit	28,1°C
Color	
Inverted interval	<input type="checkbox"/>

19.10.2 Image examples

This table explains the different color alarms (isotherms).

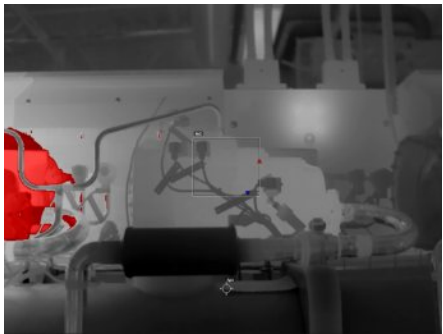
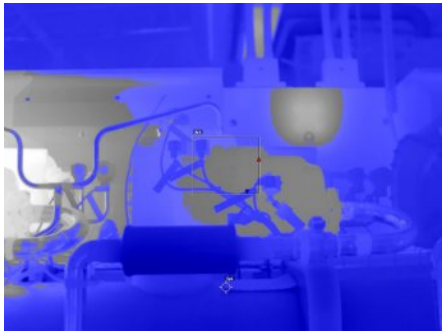
Color alarm	Image
<i>Above alarm</i>	
<i>Below alarm</i>	

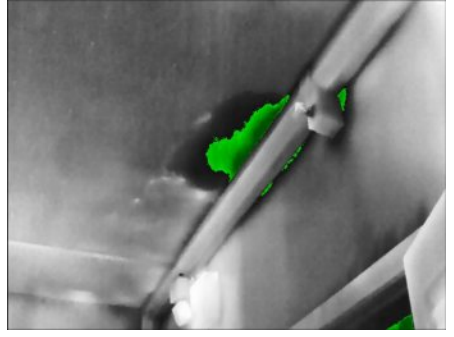
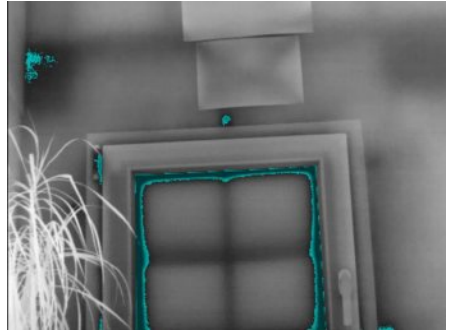
Color alarm	Image
<i>Interval alarm</i>	
<i>Humidity alarm</i>	
<i>Insulation alarm</i>	

19.10.3 Setting up above and below alarms

Follow this procedure:

1. On the measurement toolbar, select  (*Color*). This displays a menu.
2. On the menu, select one of the following:
 - *Above alarm*.
 - *Below alarm*.
3. In the right pane, take note of the parameter *Limit*. Areas in the image with a temperature *above* or *below* this temperature will be colorized with the isotherm color. You can change this limit, and also change the isotherm color on the *Color* menu.

19.10.4 Setting up an interval alarm

Follow this procedure:

1. On the measurement toolbar, select  (*Color*). This displays a menu.
2. On the menu, select *Interval alarm*.

-
- In the right pane, take note of the parameters *Upper limit* and *Lower limit*. Areas in the image with a temperature between these two temperatures will be colorized with the isotherm color. You can change these limits, and also change the isotherm color on the *Color* menu.

19.10.5 Setting up a humidity alarm

19.10.5.1 General

The humidity alarm (isotherm) can detect areas where there is a risk of mold growing, or where there is a risk of the humidity falling out as liquid water (i.e., the dew point).

19.10.5.2 Procedure

Follow this procedure:

- On the measurement toolbar, select  (*Color*). This displays a menu.
- On the menu, select *Humidity alarm*. Depending on your object, certain areas will now be colorized with an isotherm color.
- In the right pane, take note of the parameter *Calculated limit*. This is the temperature at which there is a risk of humidity. If the parameter *Relative humidity limit* is set to 100%, this is also the *dew point*, i.e., the temperature at which the humidity falls out as liquid water.

Note The parameter *Calculated limit* takes the following three parameters into account:

- Relative humidity.
- Relative humidity limit.
- Atmospheric temperature.

19.10.6 Setting up an insulation alarm

19.10.6.1 General

The insulation alarm (isotherm) can detect areas where there may be an insulation deficiency in the building. It will trigger when the insulation level falls below a preset value of the energy leakage through the building structure—the so-called *thermal index*.

Different building codes recommend different values for the thermal index, but typical values are 0.6–0.8 for new buildings. Refer to your national building code for recommendations.

19.10.6.2 Procedure

Follow this procedure:

- On the measurement toolbar, select  (*Color*). This displays a menu.
- On the menu, select *Insulation alarm*. Depending on your object, certain areas will now be colorized with an isotherm color.
- In the right pane, take note of the parameter *Calculated insulation*. This is the temperature where the insulation level falls below a preset value of the energy leakage through the building structure.

Note The parameter *Calculated insulation* takes the following three parameters into account:

- Indoor temperature.
- Outdoor temperature.
- Thermal index.

19.10.7 Setting up a custom alarm

19.10.7.1 General

A custom alarm is an alarm of any of the following types:

- *Above alarm.*
- *Below alarm.*
- *Interval alarm.*
- *Humidity alarm.*
- *Insulation alarm.*

For these custom alarms, you can specify a number of different parameters manually, compared with using the standard alarms:

- *Background.*
- *Colors* (semi-transparent or solid colors).
- *Inverted color* (for the *Interval* isotherm only).

19.10.7.2 Procedure

Follow this procedure:

1. On the measurement toolbar, select  (*Color*). This displays a menu.
2. On the menu, select *Custom alarm*.
3. In the right pane, specify the following parameters:

- For *Above* and *Below*:
 - *Background.*
 - *Limit.*
 - *Color.*
- For *Interval*:
 - *Background.*
 - *Upper limit.*
 - *Lower limit.*
 - *Color.*
 - *Inverted interval.*
- For *Humidity*:
 - *Background.*
 - *Relative humidity.*
 - *Relative humidity limit.*
 - *Atmospheric temperature.*
 - *Color.*
- For *Insulation*:
 - *Background.*
 - *Indoor temperature.*
 - *Outdoor temperature.*
 - *Insulation factor (0–1).*
 - *Color.*

19.11 Changing the local parameters for a measurement tool

19.11.1 General

For accurate measurements, it is important to set the measurement parameters. The measurement parameters stored with the image are displayed in the right pane, under *PARAMETERS*.

In some situations you may want to change a measurement (object) parameter for one measurement tool only. The reason for this could be that the measurement tool is in front of a significantly more reflective surface than other surfaces in the image, or over an object that is further away than the rest of the objects in the image, and so on.

For more information about object parameters, see section 27 *Thermographic measurement techniques*, page 129.

The following indicators are used when local parameters are activated for a measurement tool:

- In the image, an asterisk (*) is displayed next to the measurement tool.

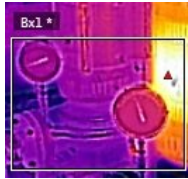

- In the result table of the Image Editor, an icon is displayed next to the measurement value.

MEASUREMENTS (°C)	
Bx1	Max: 45,2 

- In result fields and tables in infrared reports, an asterisk (*) is displayed and the local parameter values are included in brackets.

Bx1 Maximum* (Emiss=0,96 Refl.temp=68,0°F Dist=3,3ft)	45,2 °C
--	---------

19.11.2 Procedure

Follow this procedure:

1. On the measurement toolbar, select  (*Selection*).
2. Right-click the tool and select *Local parameters*.
3. In the dialog box, select *Use local parameters*.
4. Enter a value for one or more parameters.
5. Click *OK*.

19.12 Working with annotations

19.12.1 General

You can save additional information with an infrared image by using annotations. Annotations make reporting and post-processing more efficient, by providing essential information about the image, e.g., conditions and information about where an image is taken.

Some cameras allow you to add annotations directly in the camera, e.g., notes (image descriptions), text, voice, and sketch annotations. These annotations (if available) are displayed in the right pane of the Image Editor. You can also add notes (image descriptions) and text annotations to images using the Image Editor.

19.12.2 About image descriptions

19.12.2.1 What is an image description?

An image description is a brief free-form textual description that is stored in an infrared image file. It uses a standard tag in the *.jpg file format and can be retrieved by other software.

In the Image Editor and FLIR cameras, the image description is called *Note*.

19.12.2.1.1 Procedure

Follow this procedure:

1. In the right pane, type the image description in the field under *NOTE*.

19.12.3 About text annotations

19.12.3.1 What is a text annotation?

A *text annotation* is textual information about something in an image and is constructed of a group of information pairs—*label* and *value*. The reason for using text annotations is to make reporting and post-processing more efficient by providing essential information about the image, e.g., conditions, photos, and information about where the image was taken.

A text annotation is a proprietary annotation format from FLIR Systems, and the information cannot be retrieved by other vendors' software. The concept relies heavily on *interaction by the user*. In the camera, the user can select one of several values for each label. The user can also enter numerical values, and make the text annotation capture measurement values from the screen.

19.12.3.2 Creating a text annotation for an image

Follow this procedure:

1. Under *TEXT ANNOTATIONS* in the right pane, do one of the following:

Click . This adds a text annotation row. Repeat to add more rows.

- Click . This opens the *Text annotations* dialog box.

2. Enter the desired labels and values. See the image below for examples.

Text annotations		×
Label	Value	+
Company	Flir Systems	🗑️
Building	Production	🗑️
		🗑️

20.1 General

FLIR Report Studio ships with several different report templates (Microsoft Word *.dotx files). If these templates do not meet your needs, you can create your own custom infrared report templates.

Note Custom infrared report templates created in FLIR Report Studio can also be used in FLIR Tools/Tools+.

20.1.1 Few or many report templates?

It is not uncommon for a specific template to always be used for a particular customer. If this is the case, you may want to include your customer's company-specific information in the template, rather than entering it manually after the infrared report has been generated.

However, if infrared reports for several of your customers could be created using one template, or perhaps just a few, company-specific information should probably not be included in the template, since that kind of information can easily be entered when generating the report.

20.1.2 Typical structure

An infrared report template usually consists of the following types of sections:

- **INTRO:** The front cover that, for example, can include your company logo and elements of corporate identity, the title of the report, the customer's name and address, a summary table, and any additional artwork or information that you want to include.
- **DATA:** A number of different pages, containing combinations of thermal image objects, digital photo objects, table objects, summary table objects, etc. Multiple **DATA** sections with different types of content, e.g., "IR only" and "Visual only," can be included.
- **FINAL:** Your conclusions, recommendations, diagnosis, and summary description.

20.1.3 A note about working in the Microsoft Word environment

Due to the fact that the FLIR Word Add-in is an add-in to Microsoft Word, the existing features you usually use when creating a Microsoft Word document template can be used when creating your report templates.

The FLIR Word Add-in adds a number of commands that are specific to the area of infrared imaging and reporting. These commands are available on the *FLIR* tab. You use these features, along with the usual Microsoft Word features, when you create infrared report templates.

Note

- Creating a report template requires knowledge of how to create document templates in Microsoft Word. For more information about this, refer to your Microsoft Word documentation, or to the Microsoft Word online help.
- When creating a custom report template, you may find it useful to select *Show/Hide ¶* on the *Home* tab in Microsoft Word.

20.2 Creating a custom infrared report template

You can create a report template in different ways:

- Customize a basic report template.
- Modify an existing report template.

20.2.1 Customizing a basic report template

Follow this procedure:

1. On the *FLIR* tab, click *Create new template*.
2. A report template with basic layout opens, including the *INTRO*, *DATA*, and *FINAL* sections.
3. You can add more *DATA* sections to the template. For more information, see section 20.2.3 *Adding multiple DATA sections*, page 98.
4. Insert content in the report template, following the instructions in the document. You can use existing features in Microsoft Word and also add and remove objects and modify the properties of the objects as described in section 18.1 *Managing objects in the report*, page 57.
5. You can select a category for the report template. When saved, the report template will appear under the selected category in the left pane of the FLIR Report Studio wizard. For more information, see section 20.2.4 *Selecting a template category*, page 99.
6. Save the new infrared report template. Make sure that you save the template with the *.dotx file name extension.
7. Click *OK*.

20.2.2 Modifying an existing template

Follow this procedure:

1. Start Microsoft Word, but make sure that all infrared reports are closed.
2. On the *FLIR* tab, click the *Create new template* arrow. This displays a menu.
3. On the menu, click *Create from existing template*.
4. This displays the *Select Template* window.

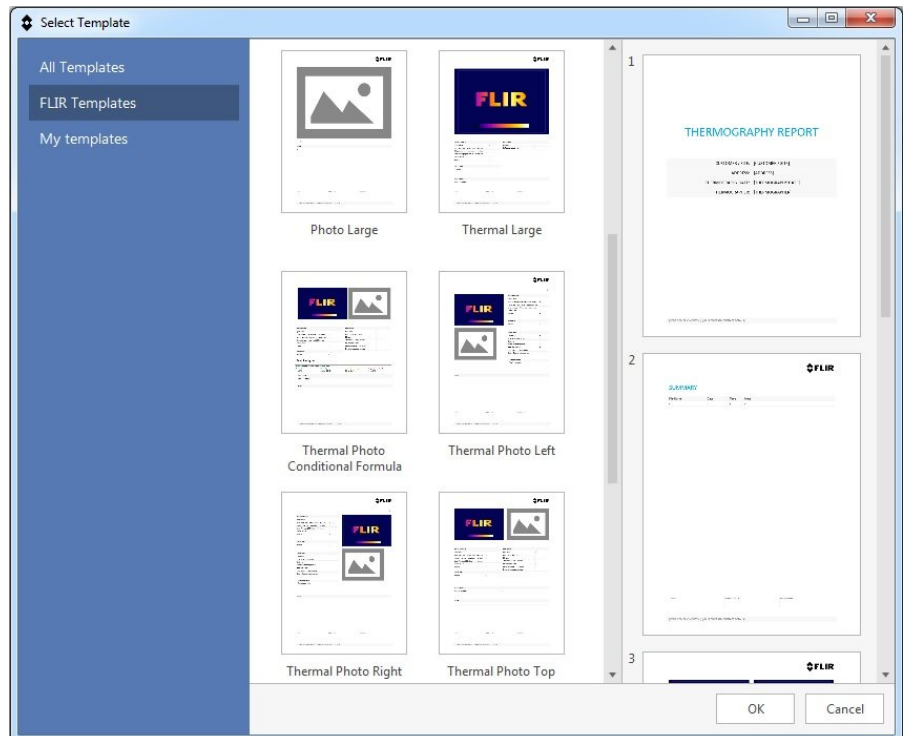

5. In the left pane, select *All Templates* to display all of the templates available in FLIR Report Studio.

6. In the center pane, click a report template. A preview of each page in the selected report template will be displayed in the right pane.

To continue with the selected template, click **OK** at the bottom of the window.

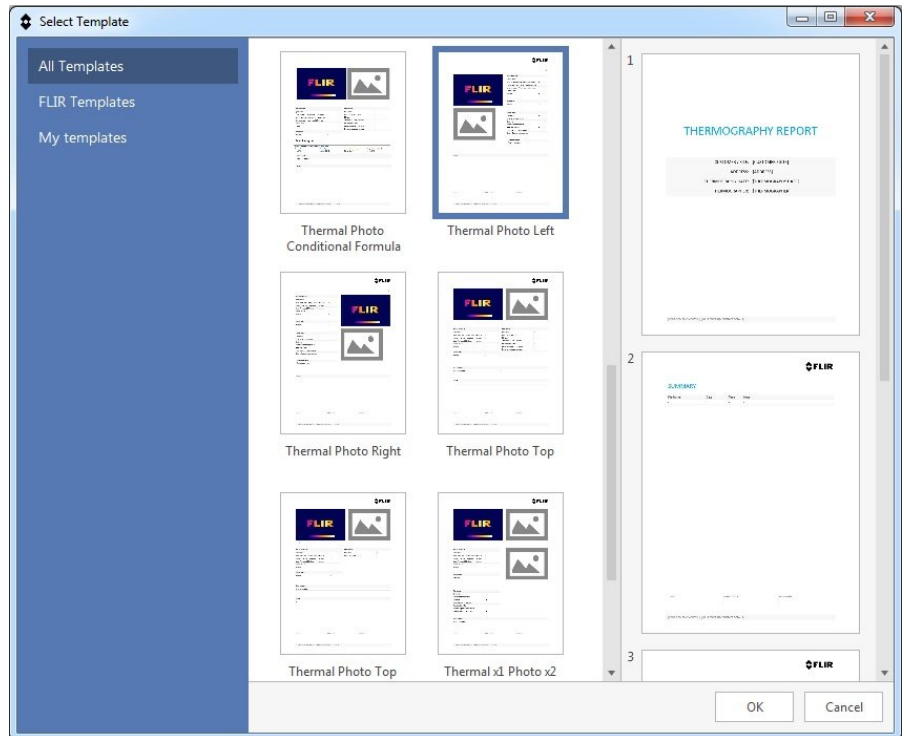

7. To avoid overwriting the original template, save the template under a different file name before making any changes. When saving the template, make sure that you save it with the *.dotx file name extension.
8. Make your changes to the original template by adding and removing objects and by modifying the properties of the objects as described in section 18.1 *Managing objects in the report*, page 57.
9. You can add more *DATA* sections to the template. For more information, see section 20.2.3 *Adding multiple DATA sections*, page 98.
10. You can select a category for the report template. When saved, the report template will appear under the selected category in the left pane of the FLIR Report Studio wizard. For more information, see section 20.2.4 *Selecting a template category*, page 99.
11. Save the new infrared report template. Make sure that you save the template with the *.dotx file name extension.

20.2.3 Adding multiple *DATA* sections

You can add one or more new *DATA* sections to the report template, with different types of content, e.g., “IR only” and “Visual only”.

Follow this procedure:

1. In the *FLIR Task Pane*, right-click the *DATA* section and select *Add Template Part*.

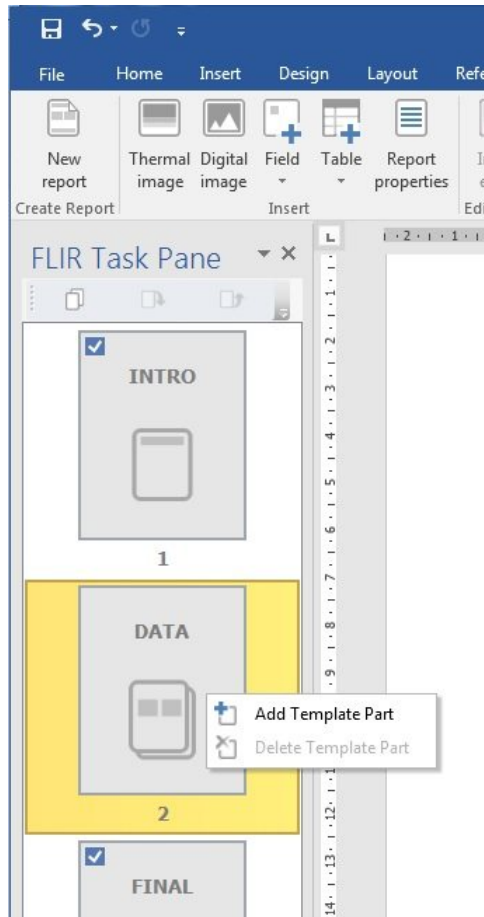

2. In the *Insert template part* dialog box, enter a name of the new section.

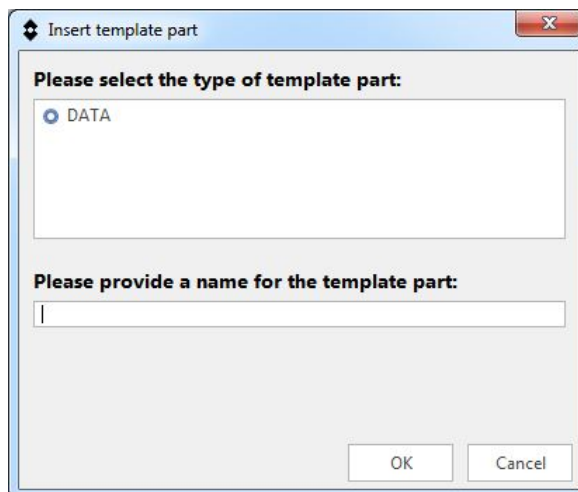

3. When completed, click *OK*.

20.2.4 Selecting a template category

You can select one or more categories for the report template. When saved and imported to the FLIR Report Studio wizard, the report template will appear under the selected categories in the left pane of the wizard.

Follow this procedure:

1. On the *FLIR* tab, click the *Settings* arrow. This displays a menu. On the menu, select *Template categories*.
2. In the *Select Template Categories* dialog box, click the *Create default* button. To create a new category, click the *Add* button.

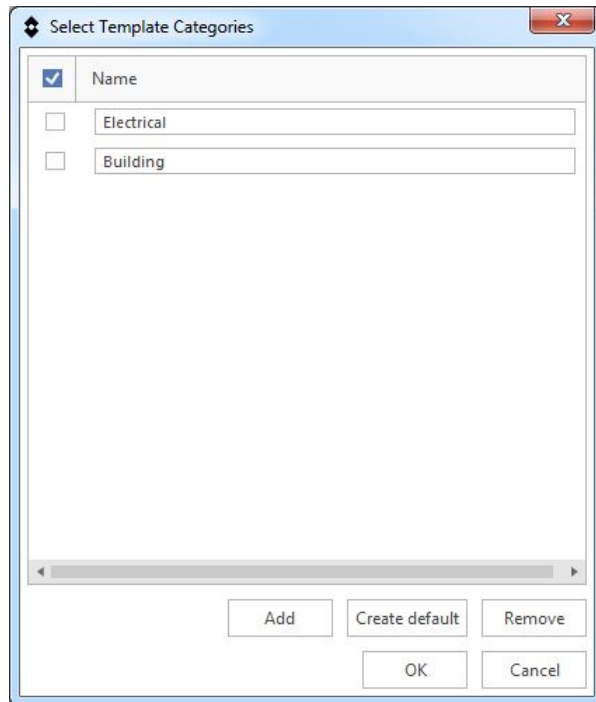

3. Select one or more categories.
4. When completed, click *OK*.

Creating reports using the FLIR Report Studio wizard

21.1 General

The FLIR Report Studio wizard allows you to easily and efficiently generate reports. The wizard gives you the opportunity to fine tune and adjust your report before it is created. You can choose different report templates, add images, edit images, move images up and down, and add report properties such as customer information and information about the inspection.

Using the FLIR Report Studio wizard is the easiest way to create a report. However, you can also create a report from a blank Microsoft Word document, by adding and removing objects and by modifying the properties of the objects as described in section 18.1 *Managing objects in the report*, page 57.

21.2 Types of reports

You can create the following types of reports using the FLIR Report Studio wizard:

1. **A flat report:** This is a report in the *.docx file format that contains infrared images, any associated visual images, and result tables. The report can be edited using ordinary Microsoft Word features, but no radiometric data is included.
2. **An editable report:** This is an advanced report in the *.docx file format that contains infrared images, any associated visual images, and result tables. In addition to basic editing, advanced radiometric analysis can be carried out using the FLIR Word Add-in features in Microsoft Word.

FLIR Report Studio ships with a number of report templates. You can also create your own templates, see section 20 *Creating report templates*, page 96.

Note You can export an editable report to a flat report or to a PDF report from the FLIR Word Add-in. For more information, see section 18.6 *Exporting a report*, page 75.

21.3 Procedure

Follow this procedure:

1. Start the FLIR Report Studio wizard by doing one of the following:
 - Select *FLIR Report Studio* from the *Start* menu (*Start > All Programs > FLIR Systems > FLIR Report Studio*).
 - On the *FLIR* tab in a Microsoft Word document, click *New Report*.
2. In the left pane, select *All Templates* to display all of the templates available in FLIR Report Studio.

Note You can also do one of the following:

- Click *Import template* to import a new template to FLIR Report Studio.
- Click *Browse for template* to locate a template to be used only for the current report. This template will not be available in FLIR Report Studio next time you create a report.

3. In the center pane, click a report template. A preview of each page in the selected report template will be displayed in the right pane.

To continue with the selected template, click *Next* at the bottom of the window.

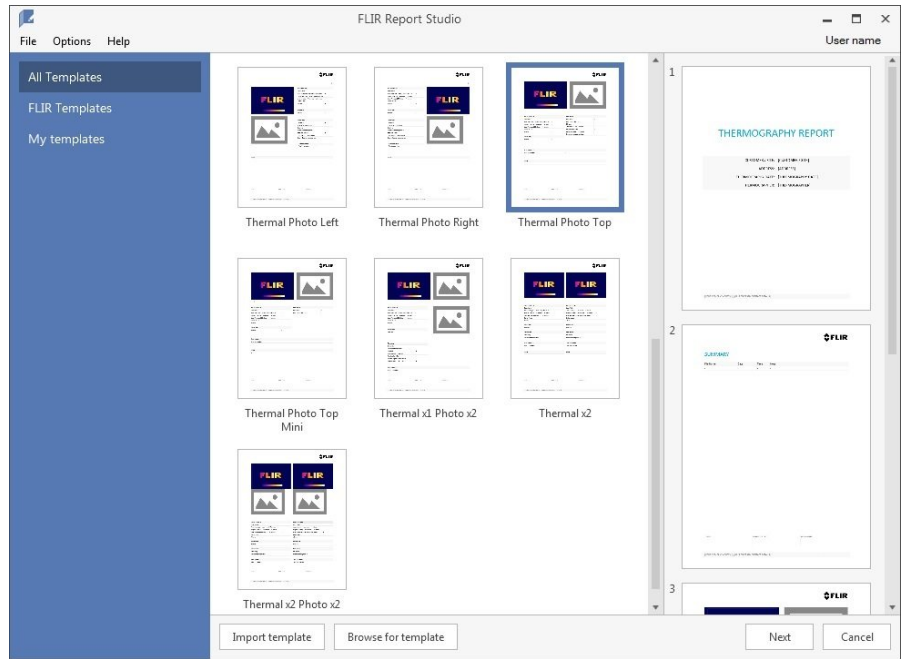



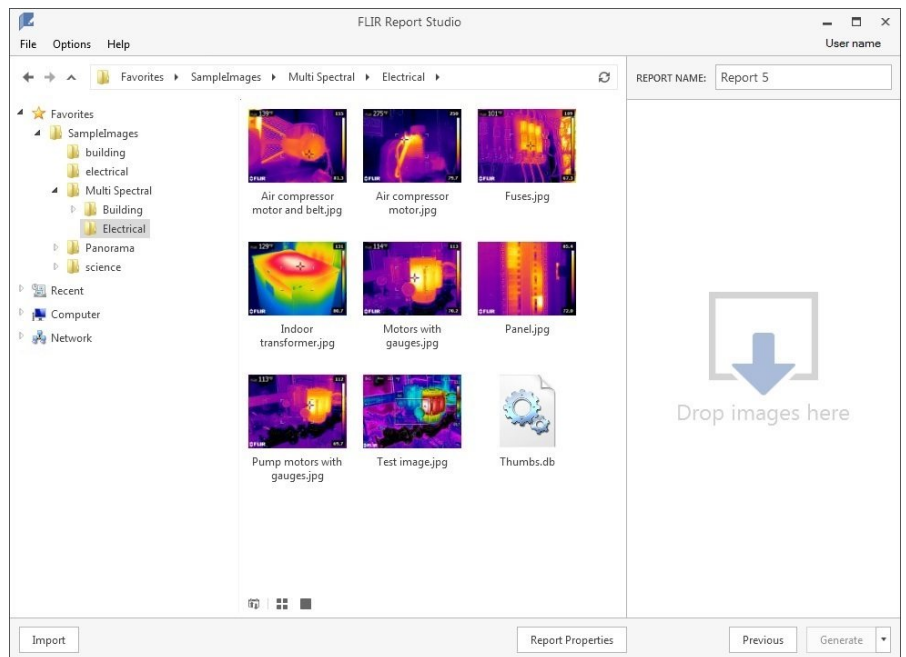

4. In the left pane, choose the folder containing the images to include in the report. You can also import images from a camera connected to the computer.

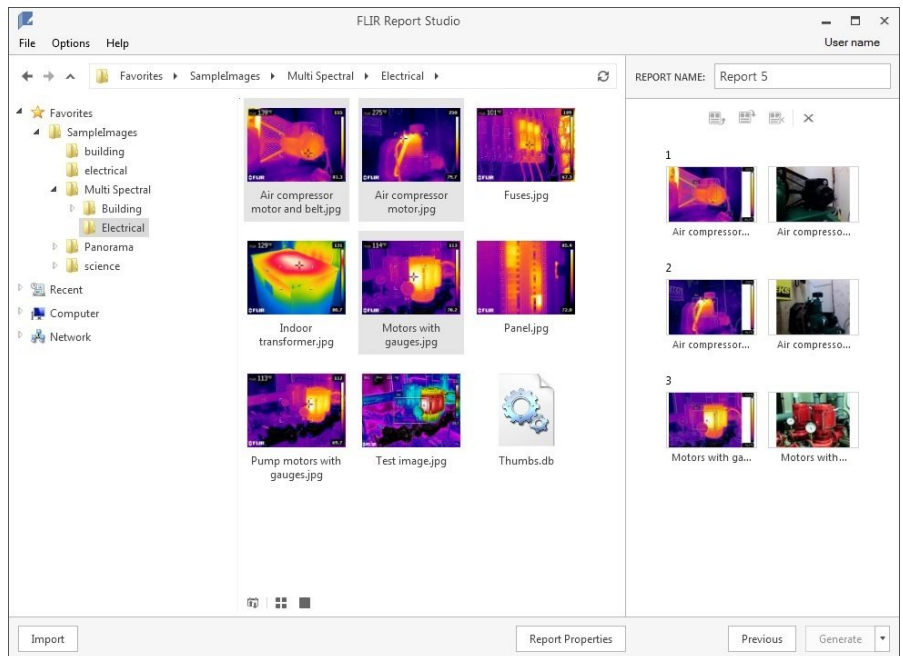

5. Drag and drop the images from the center pane into the right pane. You can also drag and drop folders into the right pane.



6. In the right pane, you can do the following:

- To change the order of images, select an image and click  (Move Up) or  (Move Down).
- To remove an image from the report, select the image and click  (Delete).
- To remove all images from the report, click  (Remove all).

7. To edit an image, do one of the following:

- Right-click the image and select *Edit Image*.
- Double-click the image.

This opens the FLIR Report Studio Image Editor. For more information, see section 19 *Analyzing and editing images using the FLIR Report Studio Image Editor*, page 77.

Note

- If you edit an image from the center pane, the original image will be changed.
- If you edit an image from the right pane, only the image in the report will be changed.

8. Enter the name of the report in the *REPORT NAME* field in the upper part of the window.

9. Click the *Generate* arrow at the bottom of the window. Select one of the following:

- *Generate an editable report* to generate a report with full radiometric data.
- *Generate a flat report* to generate a compressed report with flat infrared images and result tables.



10. The *Report Properties* dialog box is displayed.

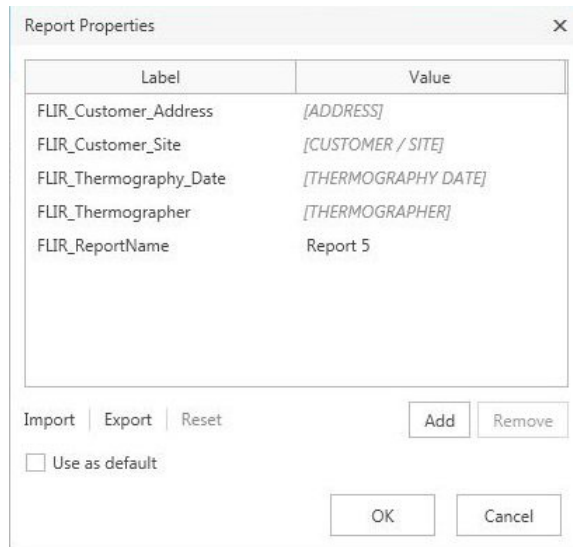

Do one or more of the following:

- Enter the customer information and information about the inspection in the predefined fields.
- Click *Import* to import properties from a previously saved text file.
- Click *Add* to add a new property.
- Select a property and click *Remove* to remove a property.
- Click *Export* to export the current property settings to a text file.

To create the report with the displayed properties, click *OK*. This generates a report saved to the reports folder, as specified in *Settings*. For more information, see section 21.5 *Changing the settings*, page 105.

11. The report opens as a Microsoft Word document. The selected image(s) and the information entered in the *Report Properties* dialog box populate the corresponding placeholders in the report.
12. (Applicable to editable reports.) To edit an image, do one of the following:
- Click the image. On the *FLIR* tab, click *Image Editor*.
 - Right-click the image and select *Edit Image*.
 - Double-click the image.

This opens the FLIR Report Studio Image Editor. For more information, see section 19 *Analyzing and editing images using the FLIR Report Studio Image Editor*, page 77.

13. (Applicable to editable reports.) To modify objects in the report, refer to section 18.1 *Managing objects in the report*, page 57.
14. Save the report.

21.4 Saving a session

A session is a way to store a report that has not yet been completed in the FLIR Report Studio wizard. You can load a saved session in the FLIR Report Studio wizard and continue with the report later.

In the FLIR Report Studio wizard, do the following:

- To save a session, select *File > Save session*.
- To load a session, select *File > Load session*.

21.5 Changing the settings

You can change the settings for FLIR Report Studio wizard.

Follow this procedure:

1. Select *Options > Settings*.
2. In the *Report* tab, you can select settings related to the creation of reports.

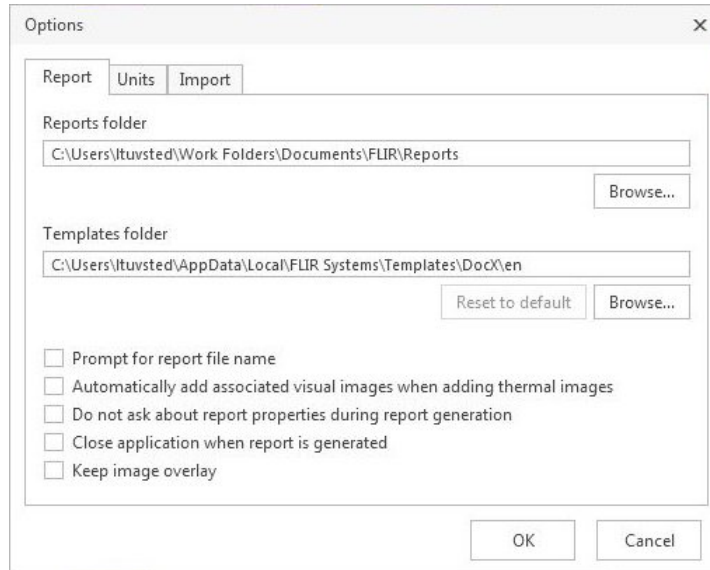

3. In the *Units* tab, you can select settings related to temperature and distance units.
 - Select the *Prefer template units* check box to apply the unit settings as specified in the report template. If no units are set in the template, the unit settings in the *Temperature* and *Distance* fields will apply.
 - Deselect the *Prefer template units* check box to apply the unit settings in the *Temperature* and *Distance* fields.

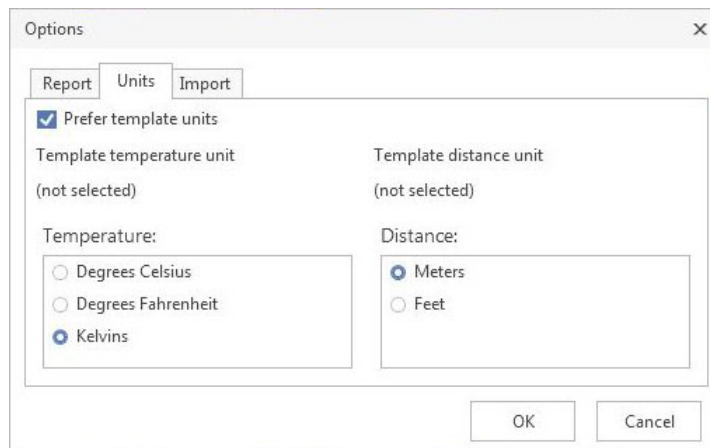

4. In the *Import* tab, you can select settings related to the import of images.

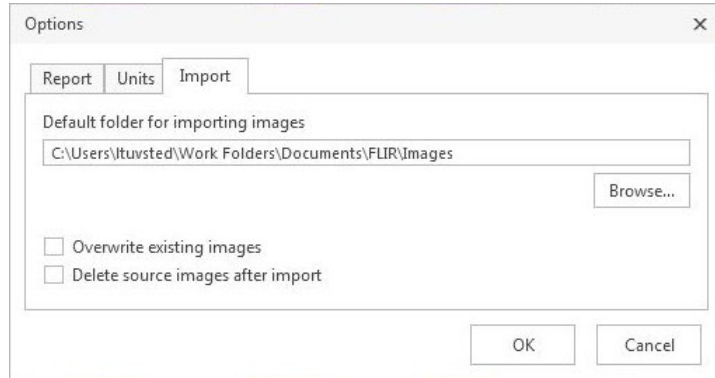

Updating the camera and PC software

22.1 Updating the PC software

22.1.1 General

You can update FLIR Tools/Tools+ with the latest service packs.

22.1.2 Procedure

Follow this procedure:

1. Start FLIR Tools/Tools+.
2. On the *Help* menu, select *Check for updates*. This displays a dialog box.



Figure 22.1 FLIR Tools/Tools+ update dialog box (example image)

3. Follow the on-screen instructions.

22.2 Updating the camera firmware

22.2.1 General

You can update your infrared camera with the latest firmware.

Note Before updating the camera you must update FLIR Tools/Tools+.

22.2.2 Procedure

Follow this procedure:

1. Connect your infrared camera to a PC.
2. Start FLIR Tools/Tools+.
3. On the *Help* menu, select *Check for updates*. This displays a dialog box.



Figure 22.2 Camera update dialog box (example).

4. Follow the on-screen instructions.

23.1 Settings relating to *Options* FLIR Tools/Tools+

23.1.1 The *Options* dialog (for program-wide options)

Note This section refers to the *Options* command on the main menu bar.

23.1.1.1 *Recording tab*

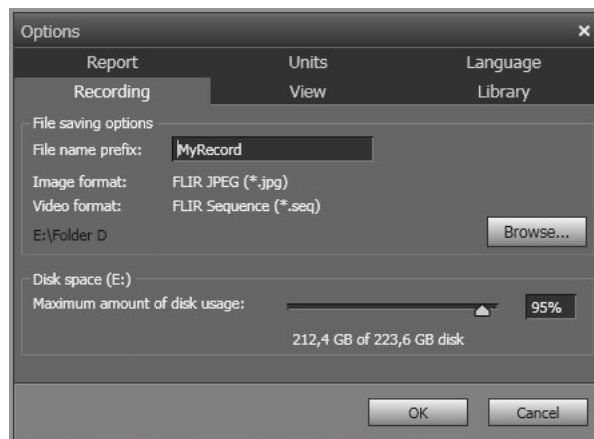

File name prefix: The prefix that will be inserted in file names for recordings.

Image format: The image format for snapshots that are saved as image files from recordings.

Video format: The video format for recordings.

Browse: Click *Browse* to specify the location where video recordings will be saved.

Disk space: The available disk space for recordings.

23.1.1.2 *View tab*

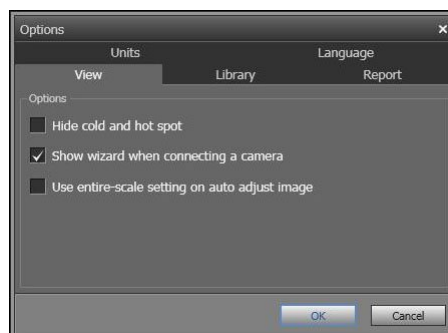

Hide cold and hot spot: To hide any existing cold and hot spots in an image, select this check box.

Show wizard when connecting a camera: To display the import guide when connecting a camera, select this checkbox.

Use entire-scale setting on auto-adjust image: (Applies to FLIR GF3xx cameras only.) To use the image's entire temperature range when importing the image into FLIR Tools/Tools+, and not only the scene temperature range, select this check box. If this check box is not selected, the image may appear considerably darker after importing, since FLIR Tools/Tools+ uses a default temperature range. For more information about the scene temperature range, see the FLIR GF3xx camera manual.

23.1.1.3 Library tab

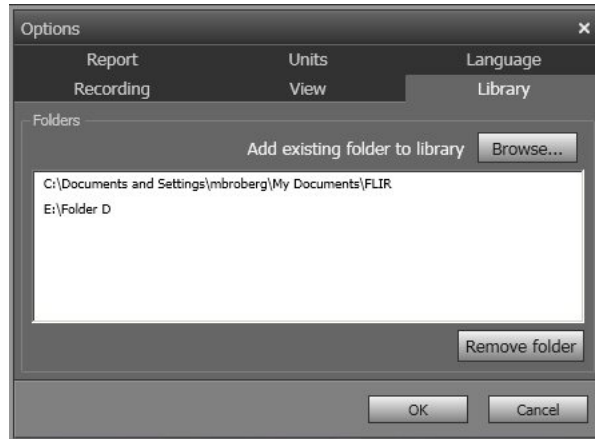

Add existing folder to library: To add an existing folder on your computer to the image library, click *Browse* and navigate to the folder.

Remove folder: To remove a folder from the image library, select the folder in the folder list and then click *Remove folder*.

23.1.1.4 Report tab



Page size: To change the page size, select a new page size in the list. Available options are *A4*, *US Letter*, and *US Legal*.

Show all parameters: To display all measurement parameters for an image when included in a report, select this checkbox.

Extract digital camera image from thermal image (if available) when generating: For cameras supporting multispectral images, all image modes are included inside a single image file—MSX, thermal, thermal fusion, thermal blending, picture-in-picture, and the digital camera image. To extract the digital camera image when generating a report, select this checkbox.

User Report Studio templates path: The file path to the program's Report Studio templates (Microsoft Word *.dotx files).

Logo: To display a logo in the top left corner of the report pages, select this checkbox. To display another logo, click *Browse* and navigate to the logo file.

Header: A text field where you can enter any text that shall be displayed in the report header.

Footer: A text field where you can enter any text that shall be displayed in the report footer.

23.1.1.5 Units tab

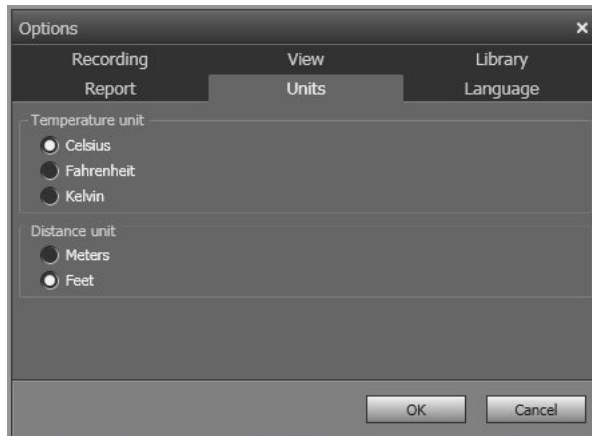

Temperature unit: The unit for temperature values in the program and the reports. To change the unit, select another unit. Available options are *Celsius*, *Fahrenheit*, *Kelvin*.

Distance unit: The unit for distance in the program and the reports. To change the unit, select another unit. Available options are *Meters*, *Feet*.

23.1.1.6 Language tab

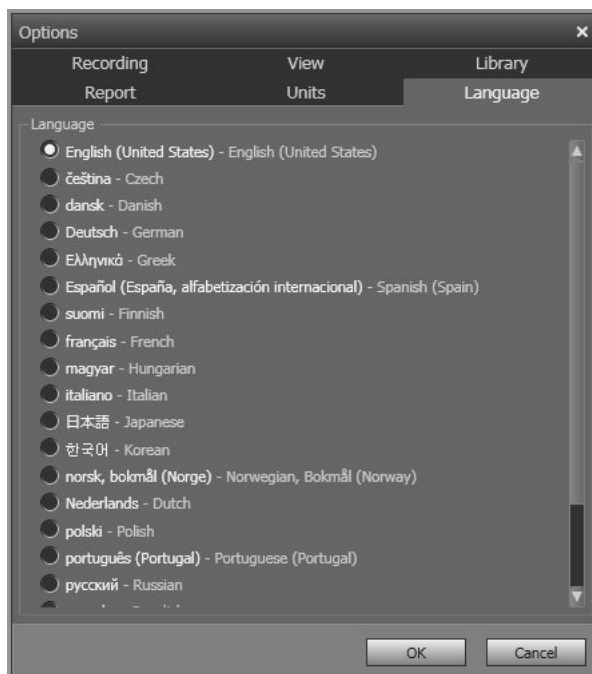

Language: To change the language, select a new language in the list.

23.1.2 The Options dialog (for plot-specific options)

Note This section refers to the *Options* command on the main menu bar.

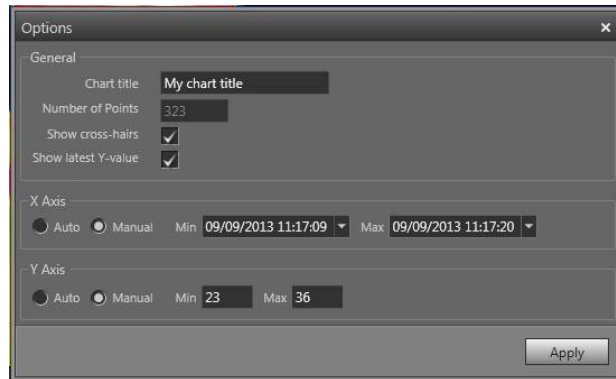



Chart title: To change the title of the plot, type a title here.

Number of points: Number of sampling points that the plot is based on.

Show cross-hairs: To display a cross-hair that moves when you move the mouse and displays the X and Y axes values, select this checkbox. 

Show latest value: To display the latest Y value, select this checkbox. 

X axis > Auto: To let FLIR Tools/Tools+ automatically set the boundaries of the X axis, select *Auto*.

X axis > Manual: To manually set the boundaries of the X axis, select *Manual* and enter the start and stop times.

Y axis > Auto: To let FLIR Tools/Tools+ automatically set the boundaries of the Y axis, select *Auto*.

Y axis > Manual: To manually set the boundaries of the Y axis, select *Manual* and enter the min. and max. values.

23.2 Settings relating to FLIR Kx3 and FLIR Kx5 series cameras

23.2.1 General

The FLIR K series is a robust and reliable infrared camera series designed to perform under extremely severe conditions. It has an intuitive interface with a design that makes it easy to control even with a gloved hand. The crisp and clear image helps you to navigate through smoke and to make quick and accurate decisions.

By connecting a FLIR Kx3 or FLIR Kx5 series camera to FLIR Tools/Tools+, you get access to a variety of settings in the camera.

23.2.2 The General settings tab

23.2.2.1 Figure

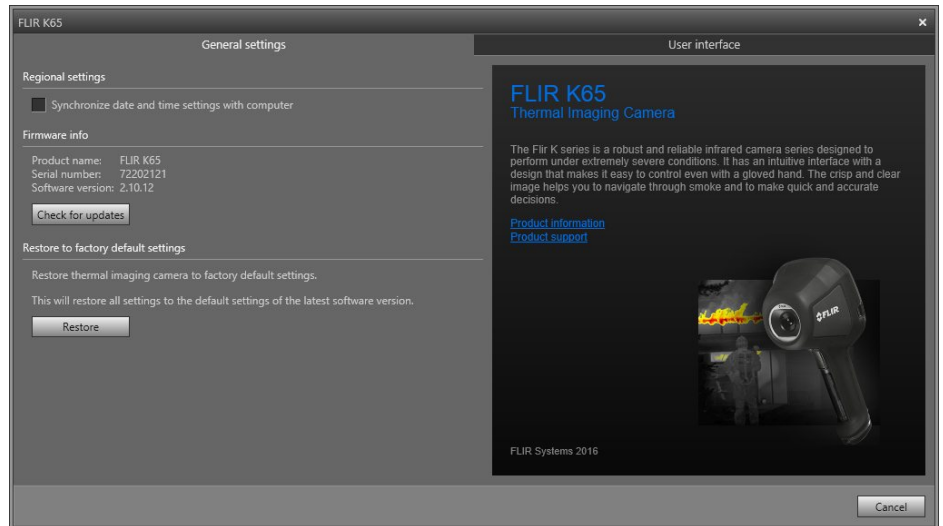

23.2.2.2 Explanation

Regional settings area: To synchronize the camera's date and time settings with the computer, select the checkbox.

Firmware info area: To check whether a newer version of the camera firmware exists, click *Check for updates* and follow the on-screen instructions.

Restore to factory default area: To restore all camera settings to the factory defaults, click *Restore*.

23.2.3 The User interface tab

23.2.3.1 Figure



23.2.3.2 Explanation

Camera modes area:

- Applicable to FLIR Kx5: To define which camera modes to enable in the camera, select the camera mode. For more information on each camera mode, see section 23.2.4 *Explanation of the different camera modes*, page 114.
- Applicable to FLIR Kx3: The camera features one camera mode: basic mode. For more information, see section 23.2.4.1.

Trigger button area: The camera has a trigger button. With the settings in the *Trigger button* area, you can select the function of the trigger button. You select what will happen when you click (short press) the trigger button and what will happen when you hold (long press) the trigger button.

- *No action, No action*: Select to disable any functionality of the trigger button. Nothing will happen when you press the trigger.
- *No action, Freeze image*: Select to make the camera freeze the image when you press and hold the trigger. The image will unfreeze when you release the trigger. Nothing will happen when you press the trigger momentarily.
- *No action, Record video* (not applicable to the FLIR K33 and FLIR K45): Select to make the camera start a recording when you press and hold the trigger. The recording will stop when you release the trigger. Nothing will happen when you press the trigger momentarily.
- *Save image, No action* (not applicable to the FLIR K33): Select to make the camera save an image when you press the trigger momentarily. Nothing will happen when you press and hold the trigger.
- *Save image, Freeze image* (not applicable to the FLIR K33): Select to make the camera save an image when you press the trigger momentarily and freeze the image when you press and hold the trigger. The image will unfreeze when you release the trigger.
- *Save image, Record video* (not applicable to the FLIR K33 and FLIR K45): Select to make the camera save an image when you press the trigger momentarily and start a recording when you press and hold the trigger. The recording will stop when you release the trigger.
- *Rec. on/off, No action* (not applicable to the FLIR K33 and FLIR K45): Select to make the camera start a recording when you press the trigger and stop the recording when you press the trigger again. Nothing will happen when you press and hold the trigger.
- *Continuous rec. (trigger disabled)* (not applicable to the FLIR K33 and FLIR K45): Select to make the camera start a continuous video recording when you turn on the camera. The recording cannot be stopped. Nothing will happen when you press the trigger.

Gain mode area:

- *Auto gain mode*: Select to make the camera automatically switch between the high-sensitivity range and the low-sensitivity range, depending on the scene temperature. The temperature level at which the camera switches between the two modes is 150°C (302°F).
- *Low gain mode*: Select to make the camera operate in the low-sensitivity range only. This has the advantage that the camera does not perform a non-uniformity correction (NUC) when an object with a temperature higher than 150°C (302°F) enters the scene. However, the disadvantage is lower sensitivity and a higher level of signal noise.

Temperature unit area: To select a different temperature unit, click *Celsius* or *Fahrenheit*.

Thermal indication area:

- *Digital readout only*: Select to display the thermal information in the image as the temperature of the spotmeter only. In modes with automatic heat colorization, the colorization of the image will remain but the static heat color reference icon will not be displayed.
- *Reference bar*: In modes with automatic heat indication colorization, a vertical heat color reference bar is displayed in the thermal indication area. This static icon shows how heat colors are applied to the range of the camera mode. The colors yellow, orange, and red correspond to a temperature-dependent change in hue as the temperature increases.

- *Temp bar*: Select to display the thermal information in the image as a temperature bar, similar to a thermometer. This displays a dynamic vertical temperature bar on the right-hand side of the image. The top of the dynamic bar represents the temperature of the measured spot. In modes with automatic heat colorization, the colorization of the image will remain, with a static heat color reference bar displayed next to the temperature bar.

Add custom boot image area: To select an image of your choice to appear during start-up, click *Browse*, and navigate to the image file. This is useful for, for example, identifying your fire department's cameras. By incorporating your fire department's logo, and a unique identity number in the image, you can keep track of your cameras. This image can also be accessed from the camera menu.

23.2.4 Explanation of the different camera modes

23.2.4.1 Basic mode

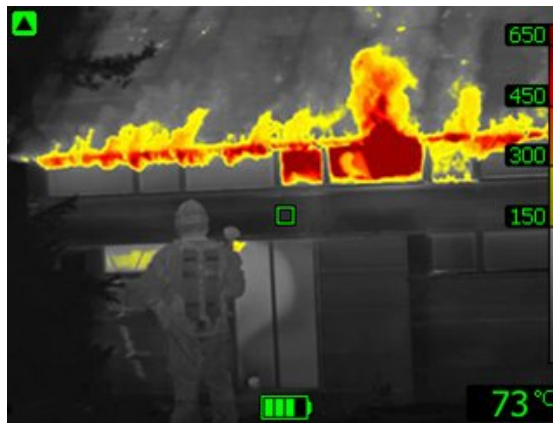

Figure 23.1 Basic mode.

Basic mode is the default mode of the camera. It is a multipurpose mode for the initial fire attack with life-saving operations and control of the fire. The camera automatically switches between the high-sensitivity range and the low-sensitivity range, to maintain an optimal infrared image while at the same time maintaining a safe and consistent heat colorization of the fire scene.

- Automatic range.
- Colorization of heat: +150 to +650°C (+302 to +1202°F).
- High-sensitivity range: -20 to +150°C (-4 to +302°F).
- Low-sensitivity range: 0 to +650°C (+32 to +1202°F).

Note To go to Basic mode from any other mode, push and hold the on/off button for less than 1 second.

23.2.4.2 Black and white firefighting mode



Figure 23.2 Black and white firefighting mode.

Black and white firefighting mode is a standardized firefighting mode based on Basic mode. It is a multipurpose mode for the initial fire intervention that includes life-saving operations and control of the fire. It is specifically designed for fire services that do not want to use the heat colorization feature.

The camera automatically switches between the high-sensitivity range and the low-sensitivity range, to maintain an optimal infrared image.

- Automatic range.
- High-sensitivity range: -20 to $+150^{\circ}\text{C}$ (-4 to $+302^{\circ}\text{F}$).
- Low-sensitivity range: 0 to $+650^{\circ}\text{C}$ ($+32$ to $+1202^{\circ}\text{F}$).

23.2.4.3 Fire mode

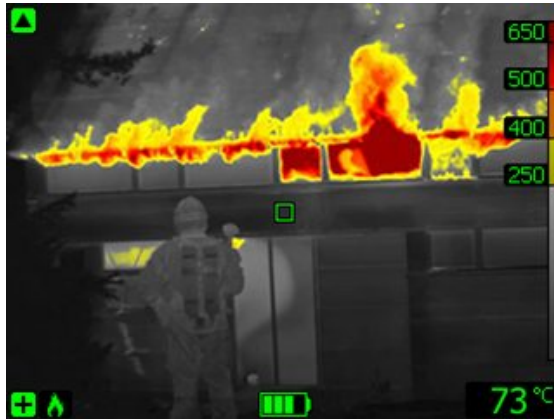

Figure 23.3 Fire mode.

Fire mode is similar to Basic mode, but with a higher-temperature starting point for the heat colorization. It is suitable for fire scenes with higher background temperatures, where there are already a lot of open flames and a high background temperature. The camera automatically switches between the high-sensitivity range and the low-sensitivity range, to maintain an optimal infrared image while at the same time maintaining a safe and consistent heat colorization.

- Automatic range.
- Colorization of heat: $+250$ to $+650^{\circ}\text{C}$ ($+482$ to $+1202^{\circ}\text{F}$).
- High-sensitivity range: -20 to $+150^{\circ}\text{C}$ (-4 to $+302^{\circ}\text{F}$).
- Low-sensitivity range: 0 to $+650^{\circ}\text{C}$ ($+32$ to $+1202^{\circ}\text{F}$).

23.2.4.4 Search and rescue mode

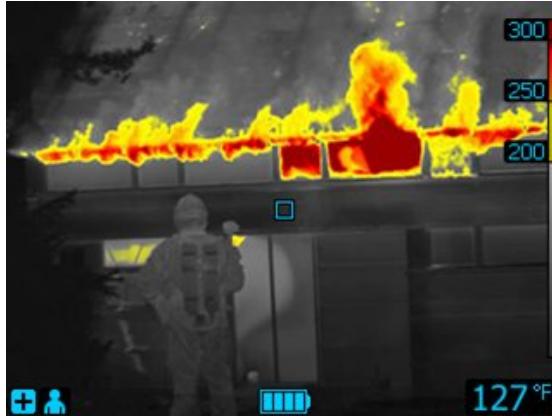

Figure 23.4 Search and rescue mode.

Search and rescue mode is optimized for maintaining high contrast in the infrared image while searching for people in landscapes, buildings, or traffic accident scenes.

- High-sensitivity range only.
- Colorization of heat: +100 to +150°C (+212 to +302°F).
- High-sensitivity range: -20 to +150°C (-4 to +302°F).

23.2.4.5 Heat detection mode



Figure 23.5 Heat detection mode.

Heat detection mode is optimized for searching hotspots during overhaul after the fire is out—typically to ensure that there is no remaining hidden fire. This mode can also be used to find thermal patterns (e.g., signs of people in car seats after accidents), to ensure that everyone has been found. This mode can also be used to search for people in water and open landscapes.

- High-sensitivity range only.
- Colorization of heat: the 20% highest temperatures in the scene.
- High-sensitivity range: -20 to +150°C (-4 to +302°F).

23.3 Settings relating to FLIR Kx series cameras

23.3.1 General

The FLIR K series is a robust and reliable infrared camera series designed to perform under extremely severe conditions. It has an intuitive interface with a design that makes

it easy to control even with a gloved hand. The crisp and clear image helps you to navigate through smoke and to make quick and accurate decisions.

By connecting a FLIR Kx series camera to FLIR Tools/Tools+, you get access to a variety of settings in the camera.

23.3.2 The *General settings* tab

23.3.2.1 *Figure*

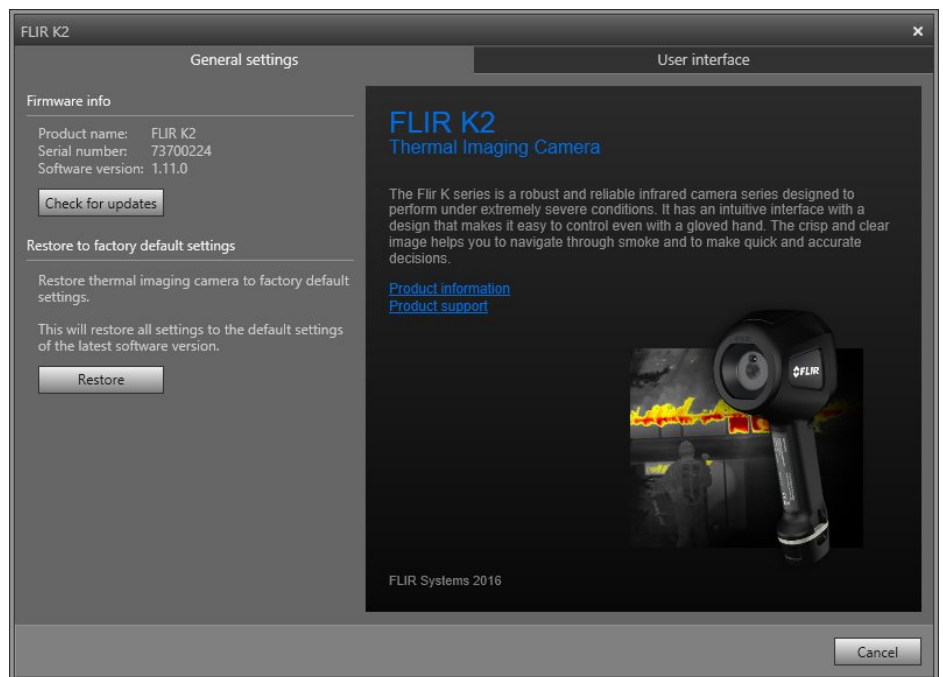

23.3.2.2 *Explanation*

Firmware info area: To check whether a newer version of the camera firmware exists, click *Check for updates*, and follow the on-screen instructions.

Restore to factory default area: To restore all camera settings to the factory defaults, click *Restore*.

23.3.3 The User interface tab

23.3.3.1 Figure

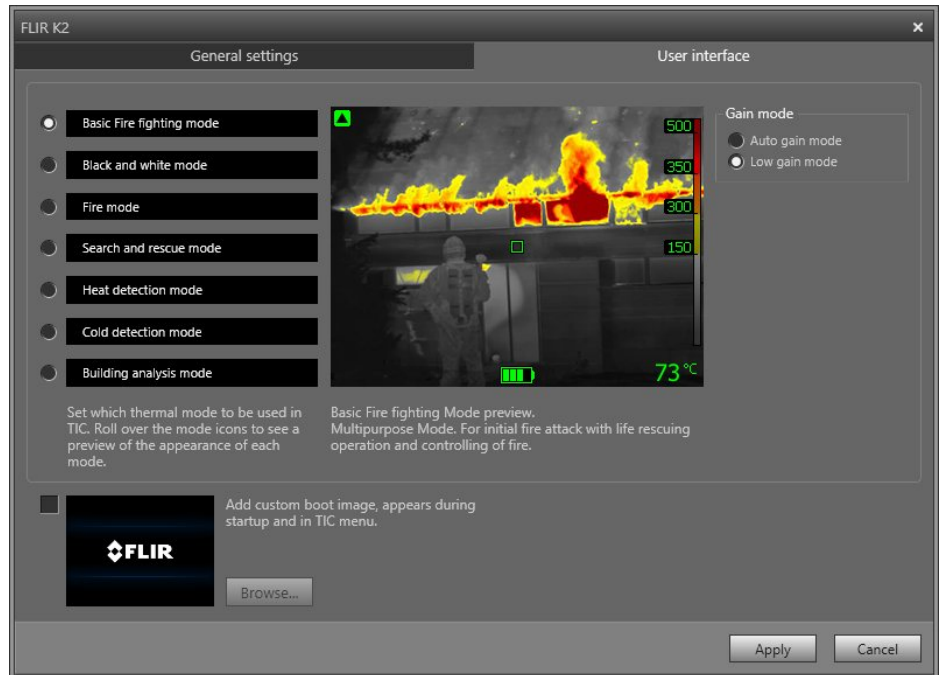

23.3.3.2 Explanation

Camera modes area: To define which camera modes to enable in the camera, select the camera mode. For more information on each camera mode, see section 23.3.4 *Explanation of the different camera modes*, page 119.

Gain mode area:

- **Auto gain mode:** Select to make the camera automatically switch between the high-sensitivity range and the low-sensitivity range, depending on the scene temperature. The temperature level at which the camera switches between the two modes is +150°C (+302°F).
- **Low gain mode:** Select to make the camera work in the low-sensitivity range only. This has the advantage that the camera does not perform a non-uniformity correction when an object with a temperature higher than +150°C (+302°F) enters the scene. However, the disadvantage is lower sensitivity and a higher level of signal noise.

Add custom boot image area: To specify your own unique image to appear during start-up, click *Browse*, and navigate to the image file. This is useful for, for example, identifying your fire department's cameras. By incorporating your fire department's logo, and a unique identity number in the image, you can keep track of your cameras.

23.3.4 Explanation of the different camera modes

23.3.4.1 Basic mode

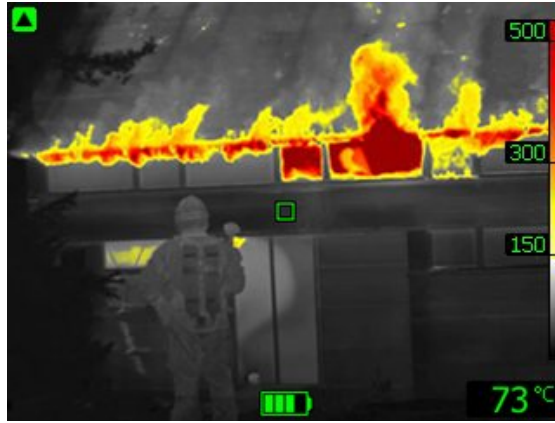

Figure 23.6 Basic mode.

The Basic mode is the default mode of the camera. It is a multipurpose mode for the initial fire attack with life rescuing operation and control of the fire. The camera automatically switches between the high-sensitivity range and the low-sensitivity range, to maintain an optimal infrared image while at the same time maintaining a safe and consistent heat colorization of the fire scene.

- Automatic range.
- Colorization of heat: +150 to +500°C (+302 to +932°F).
- High-sensitivity range: -20 to +150°C (-4 to +302°F).
- Low-sensitivity range: 0 to +500°C (+32 to +932°F).

23.3.4.2 Black and white firefighting mode



Figure 23.7 Black and white firefighting mode.

The *black and white firefighting mode* is a standardized firefighting mode based on the Basic mode. It is a multipurpose mode for the initial fire intervention that includes life rescuing operations and control of the fire. It is specifically designed for fire services that do not want to use the heat colorization feature.

The camera automatically switches between the high-sensitivity range and the low-sensitivity range, to maintain an optimal infrared image.

- Automatic range.
- High-sensitivity range: -20 to +150°C (-4 to +302°F).
- Low-sensitivity range: 0 to +500°C (+32 to +932°F).

23.3.4.3 Fire mode

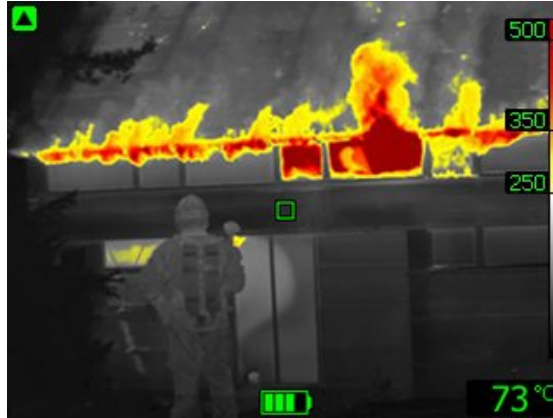

Figure 23.8 Fire mode.

The *fire mode* is similar to the Basic mode, but with a higher-temperature starting point for the heat colorization. It is suitable for fire scenes with higher background temperatures, where there are already a lot of open flames and a high background temperature. The camera automatically switches between the high-sensitivity range and the low-sensitivity range, to maintain an optimal infrared image while at the same time maintaining a safe and consistent heat colorization.

- Automatic range.
- Colorization of heat: +250 to +500°C (+ 482 to +932°F).
- High-sensitivity range: -20 to +150°C (-4 to +302°F).
- Low-sensitivity range: 0 to +500°C (+32 to +932°F).

23.3.4.4 Search and rescue mode

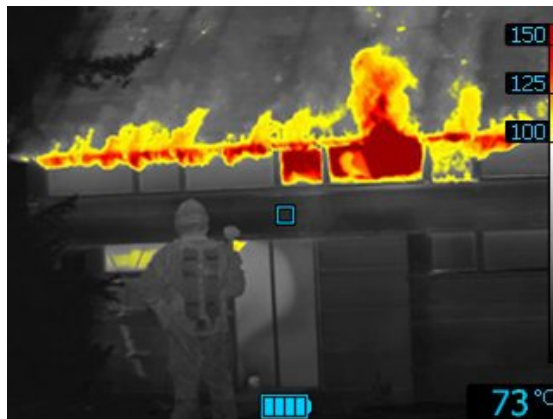

Figure 23.9 Search and rescue mode.

The *search and rescue mode* is optimized for maintaining high contrast in the infrared image while searching for people in landscapes, buildings, or traffic accident scenes.

- High-sensitivity range only.
- Colorization of heat: +100 to +150°C (+212 to +302°F).
- High-sensitivity range: -20 to +150°C (-4 to +302°F).

23.3.4.5 Heat detection mode



Figure 23.10 Heat detection mode.

The *heat detection mode* is optimized for searching hotspots during overhaul after the fire is out—typically to ensure that there is no remaining hidden fire. This mode can also be used to find thermal patterns (e.g., signs of people in car seats after accidents), to ensure that everyone has been found. This mode can also be used to search for people in water and open landscapes.

- High-sensitivity range only.
- Colorization of heat: the 20% highest temperatures in the scene.
- High-sensitivity range: -20 to $+150^{\circ}\text{C}$ (-4 to $+302^{\circ}\text{F}$).

23.3.4.6 Cold detection mode



Figure 23.11 Cold detection mode.

The *cold detection mode* is optimized for searching coldspots—typically to find drafts and air flows.

- High-sensitivity range only.
- Colorization of cold: the 20% lowest temperatures in the scene.
- High-sensitivity range: -20 to $+150^{\circ}\text{C}$ (-4 to $+302^{\circ}\text{F}$).

23.3.4.7 Building analysis mode



Figure 23.12 Building analysis mode.

The *building analysis mode* is suitable for the analysis of buildings and the detection of building-related anomalies. The thermal image can provide information on structural, mechanical, plumbing, and electrical constructions as well as an indication of moisture, wetness, and air infiltration.

In this mode, the camera uses an iron color palette to display the different temperatures, where black, blue, and purple are for the coldest areas, followed by red, orange, and yellow for the mid-range and going to white for the hottest parts. The temperature scale is automatically adjusted to the thermal content of the image.

24.1 General

FLIR Tools/Tools+ supports several radiometric and non-radiometric file formats.

24.2 Radiometric file formats

FLIR Tools/Tools+ supports the following radiometric file formats:

- FLIR Systems radiometric *.jpg.
- FLIR Systems radiometric *.img.
- FLIR Systems radiometric *.fff.
- FLIR Systems radiometric *.seq (video files).
- FLIR Systems radiometric *.csq (video files).

24.3 Non-radiometric file formats

FLIR Tools/Tools+ supports the following non-radiometric file formats:

- *.jpg.
- *.mp4 (video files).
- *.avi (video files).
- *.pdf (reports and imagesheets).
- *.docx (as reports).

FLIR Systems was established in 1978 to pioneer the development of high-performance infrared imaging systems, and is the world leader in the design, manufacture, and marketing of thermal imaging systems for a wide variety of commercial, industrial, and government applications. Today, FLIR Systems embraces five major companies with outstanding achievements in infrared technology since 1958—the Swedish AGEMA Infrared Systems (formerly AGA Infrared Systems), the three United States companies Indigo Systems, FSI, and Inframetrics, and the French company Cedic.

Since 2007, FLIR Systems has acquired several companies with world-leading expertise in sensor technologies:

- Extech Instruments (2007)
- Ifara Tecnologías (2008)
- Salvador Imaging (2009)
- OmniTech Partners (2009)
- Directed Perception (2009)
- Raymarine (2010)
- ICx Technologies (2010)
- TackTick Marine Digital Instruments (2011)
- Aerius Photonics (2011)
- Lorex Technology (2012)
- Traficon (2012)
- MARSS (2013)
- DigitalOptics micro-optics business (2013)
- DVTEL (2015)
- Point Grey Research (2016)
- Prox Dynamics (2016)

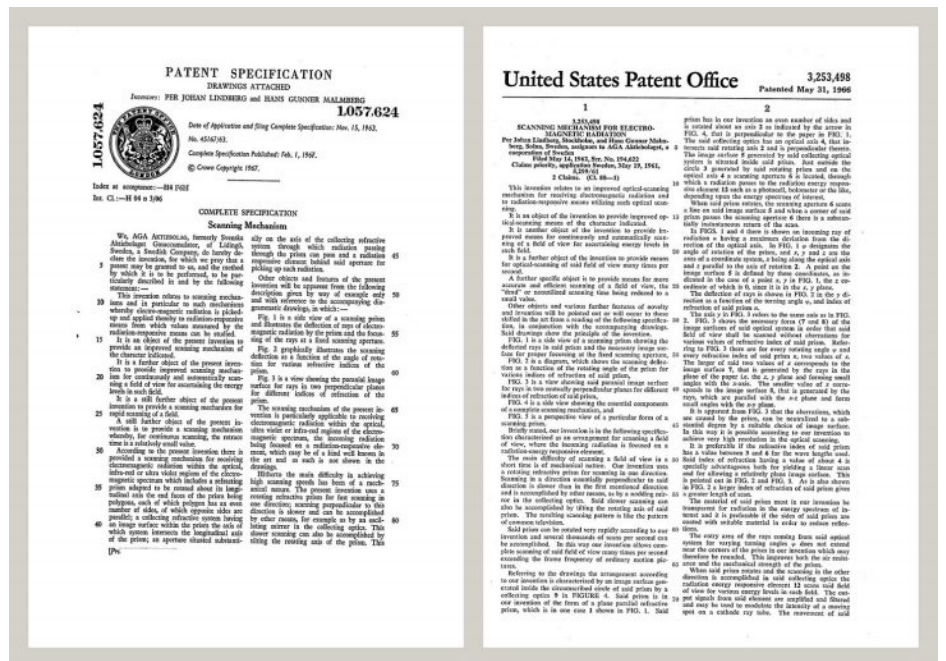

Figure 25.1 Patent documents from the early 1960s

FLIR Systems has three manufacturing plants in the United States (Portland, OR, Boston, MA, Santa Barbara, CA) and one in Sweden (Stockholm). Since 2007 there is also a manufacturing plant in Tallinn, Estonia. Direct sales offices in Belgium, Brazil, China, France, Germany, Great Britain, Hong Kong, Italy, Japan, Korea, Sweden, and the USA—together with a worldwide network of agents and distributors—support our international customer base.

FLIR Systems is at the forefront of innovation in the infrared camera industry. We anticipate market demand by constantly improving our existing cameras and developing new ones. The company has set milestones in product design and development such as the introduction of the first battery-operated portable camera for industrial inspections, and the first uncooled infrared camera, to mention just two innovations.



Figure 25.2 1969: Thermovision Model 661. The camera weighed approximately 25 kg (55 lb.), the oscilloscope 20 kg (44 lb.), and the tripod 15 kg (33 lb.). The operator also needed a 220 VAC generator set, and a 10 L (2.6 US gallon) jar with liquid nitrogen. To the left of the oscilloscope the Polaroid attachment (6 kg/13 lb.) can be seen.



Figure 25.3 2015: FLIR One, an accessory to iPhone and Android mobile phones. Weight: 90 g (3.2 oz.).

FLIR Systems manufactures all vital mechanical and electronic components of the camera systems itself. From detector design and manufacturing, to lenses and system electronics, to final testing and calibration, all production steps are carried out and supervised by our own engineers. The in-depth expertise of these infrared specialists ensures the accuracy and reliability of all vital components that are assembled into your infrared camera.

25.1 More than just an infrared camera

At FLIR Systems we recognize that our job is to go beyond just producing the best infrared camera systems. We are committed to enabling all users of our infrared camera systems to work more productively by providing them with the most powerful camera–software combination. Especially tailored software for predictive maintenance, R & D, and process monitoring is developed in-house. Most software is available in a wide variety of languages.

We support all our infrared cameras with a wide variety of accessories to adapt your equipment to the most demanding infrared applications.

25.2 Sharing our knowledge

Although our cameras are designed to be very user-friendly, there is a lot more to thermography than just knowing how to handle a camera. Therefore, FLIR Systems has founded the Infrared Training Center (ITC), a separate business unit, that provides certified training courses. Attending one of the ITC courses will give you a truly hands-on learning experience.

The staff of the ITC are also there to provide you with any application support you may need in putting infrared theory into practice.

25.3 Supporting our customers

FLIR Systems operates a worldwide service network to keep your camera running at all times. If you discover a problem with your camera, local service centers have all the equipment and expertise to solve it within the shortest possible time. Therefore, there is no need to send your camera to the other side of the world or to talk to someone who does not speak your language.

Term	Definition
Absorption and emission ¹	The capacity or ability of an object to absorb incident radiated energy is always the same as the capacity to emit its own energy as radiation
Apparent temperature	uncompensated reading from an infrared instrument, containing all radiation incident on the instrument, regardless of its sources ²
Color palette	assigns different colors to indicate specific levels of apparent temperature. Palettes can provide high or low contrast, depending on the colors used in them
Conduction	direct transfer of thermal energy from molecule to molecule, caused by collisions between the molecules
Convection	heat transfer mode where a fluid is brought into motion, either by gravity or another force, thereby transferring heat from one place to another
Diagnostics	examination of symptoms and syndromes to determine the nature of faults or failures ³
Direction of heat transfer ⁴	Heat will spontaneously flow from hotter to colder, thereby transferring thermal energy from one place to another ⁵
Emissivity	ratio of the power radiated by real bodies to the power that is radiated by a blackbody at the same temperature and at the same wavelength ⁶
Energy conservation ⁷	The sum of the total energy contents in a closed system is constant
Exitant radiation	radiation that leaves the surface of an object, regardless of its original sources
Heat	thermal energy that is transferred between two objects (systems) due to their difference in temperature
Heat transfer rate ⁸	The heat transfer rate under steady state conditions is directly proportional to the thermal conductivity of the object, the cross-sectional area of the object through which the heat flows, and the temperature difference between the two ends of the object. It is inversely proportional to the length, or thickness, of the object ⁹
Incident radiation	radiation that strikes an object from its surroundings
IR thermography	process of acquisition and analysis of thermal information from non-contact thermal imaging devices
Isotherm	replaces certain colors in the scale with a contrasting color. It marks an interval of equal apparent temperature ¹⁰
Qualitative thermography	thermography that relies on the analysis of thermal patterns to reveal the existence of and to locate the position of anomalies ¹¹
Quantitative thermography	thermography that uses temperature measurement to determine the seriousness of an anomaly, in order to establish repair priorities ¹¹

1. Kirchhoff's law of thermal radiation.

2. Based on ISO 18434-1:2008 (en).

3. Based on ISO 13372:2004 (en).

4. 2nd law of thermodynamics.

5. This is a consequence of the 2nd law of thermodynamics, the law itself is more complicated.

6. Based on ISO 16714-3:2016 (en).

7. 1st law of thermodynamics.

8. Fourier's law.

9. This is the one-dimensional form of Fourier's law, valid for steady-state conditions.

10. Based on ISO 18434-1:2008 (en)

11. Based on ISO 10878-2013 (en).

Term	Definition
Radiative heat transfer	Heat transfer by the emission and absorption of thermal radiation
Reflected apparent temperature	apparent temperature of the environment that is reflected by the target into the IR camera ¹²
Spatial resolution	ability of an IR camera to resolve small objects or details
Temperature	measure of the average kinetic energy of the molecules and atoms that make up the substance
Thermal energy	total kinetic energy of the molecules that make up the object ¹³
Thermal gradient	gradual change in temperature over distance ¹²
Thermal tuning	process of putting the colors of the image on the object of analysis, in order to maximize contrast

12. Based on ISO 16714-3:2016 (en).

13. Thermal energy is part of the internal energy of an object.

27.1 Introduction

An infrared camera measures and images the emitted infrared radiation from an object. The fact that radiation is a function of object surface temperature makes it possible for the camera to calculate and display this temperature.

However, the radiation measured by the camera does not only depend on the temperature of the object but is also a function of the emissivity. Radiation also originates from the surroundings and is reflected in the object. The radiation from the object and the reflected radiation will also be influenced by the absorption of the atmosphere.

To measure temperature accurately, it is therefore necessary to compensate for the effects of a number of different radiation sources. This is done on-line automatically by the camera. The following object parameters must, however, be supplied for the camera:

- The emissivity of the object
- The reflected apparent temperature
- The distance between the object and the camera
- The relative humidity
- Temperature of the atmosphere

27.2 Emissivity

The most important object parameter to set correctly is the emissivity which, in short, is a measure of how much radiation is emitted from the object, compared to that from a perfect blackbody of the same temperature.

Normally, object materials and surface treatments exhibit emissivity ranging from approximately 0.1 to 0.95. A highly polished (mirror) surface falls below 0.1, while an oxidized or painted surface has a higher emissivity. Oil-based paint, regardless of color in the visible spectrum, has an emissivity over 0.9 in the infrared. Human skin exhibits an emissivity 0.97 to 0.98.

Non-oxidized metals represent an extreme case of perfect opacity and high reflexivity, which does not vary greatly with wavelength. Consequently, the emissivity of metals is low – only increasing with temperature. For non-metals, emissivity tends to be high, and decreases with temperature.

27.2.1 Finding the emissivity of a sample

27.2.1.1 *Step 1: Determining reflected apparent temperature*

Use one of the following two methods to determine reflected apparent temperature:

27.2.1.1.1 Method 1: Direct method

Follow this procedure:

1. Look for possible reflection sources, considering that the incident angle = reflection angle ($a = b$).

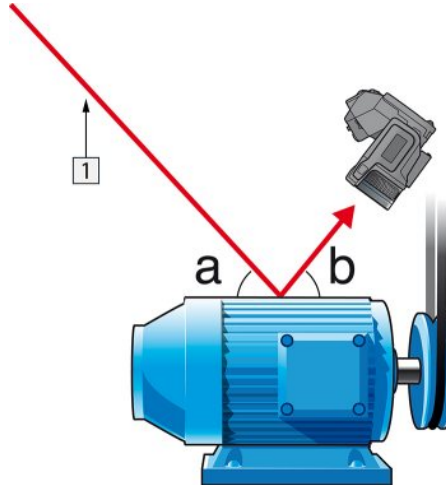

Figure 27.1 1 = Reflection source

2. If the reflection source is a spot source, modify the source by obstructing it using a piece of cardboard.

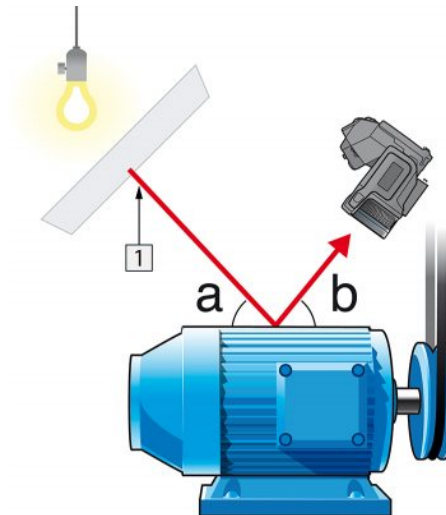

Figure 27.2 1 = Reflection source

3. Measure the radiation intensity (= apparent temperature) from the reflection source using the following settings:

- Emissivity: 1.0
- D_{obj} : 0

You can measure the radiation intensity using one of the following two methods:

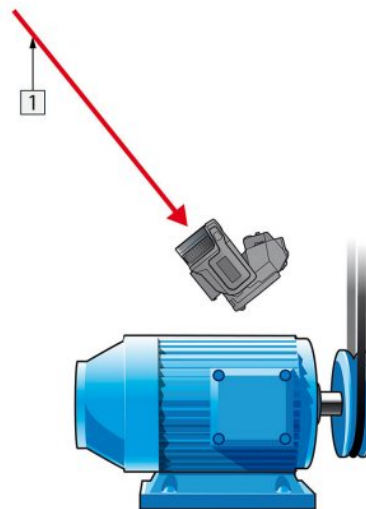

Figure 27.3 1 = Reflection source

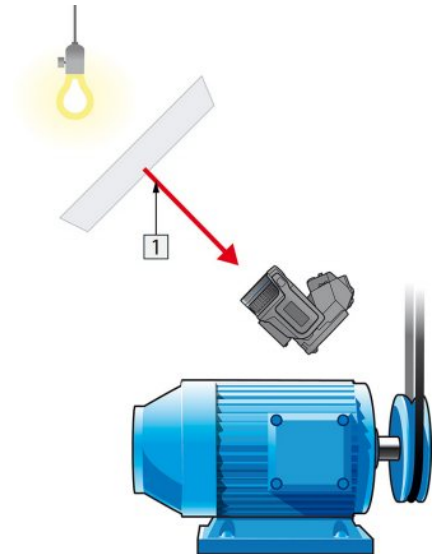

Figure 27.4 1 = Reflection source

You can not use a thermocouple to measure reflected apparent temperature, because a thermocouple measures *temperature*, but apparent temperature is *radiation intensity*.

27.2.1.1.2 Method 2: Reflector method

Follow this procedure:

1. Crumble up a large piece of aluminum foil.
2. Uncrumble the aluminum foil and attach it to a piece of cardboard of the same size.
3. Put the piece of cardboard in front of the object you want to measure. Make sure that the side with aluminum foil points to the camera.
4. Set the emissivity to 1.0.

5. Measure the apparent temperature of the aluminum foil and write it down. The foil is considered a perfect reflector, so its apparent temperature equals the reflected apparent temperature from the surroundings.

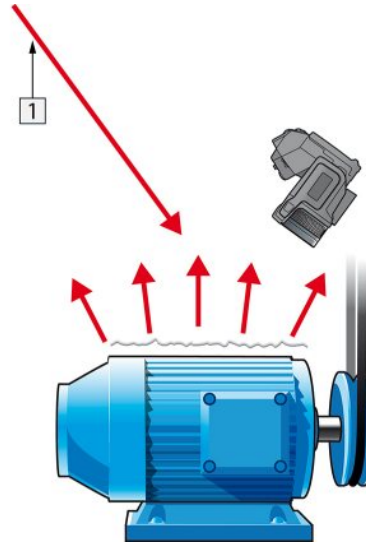

Figure 27.5 Measuring the apparent temperature of the aluminum foil.

27.2.1.2 Step 2: Determining the emissivity

Follow this procedure:

1. Select a place to put the sample.
2. Determine and set reflected apparent temperature according to the previous procedure.
3. Put a piece of electrical tape with known high emissivity on the sample.
4. Heat the sample at least 20 K above room temperature. Heating must be reasonably even.
5. Focus and auto-adjust the camera, and freeze the image.
6. Adjust *Level* and *Span* for best image brightness and contrast.
7. Set emissivity to that of the tape (usually 0.97).
8. Measure the temperature of the tape using one of the following measurement functions:
 - *Isotherm* (helps you to determine both the temperature and how evenly you have heated the sample)
 - *Spot* (simpler)
 - *Box Avg* (good for surfaces with varying emissivity).
9. Write down the temperature.
10. Move your measurement function to the sample surface.
11. Change the emissivity setting until you read the same temperature as your previous measurement.
12. Write down the emissivity.

Note

- Avoid forced convection
- Look for a thermally stable surrounding that will not generate spot reflections
- Use high quality tape that you know is not transparent, and has a high emissivity you are certain of
- This method assumes that the temperature of your tape and the sample surface are the same. If they are not, your emissivity measurement will be wrong.

27.3 Reflected apparent temperature

This parameter is used to compensate for the radiation reflected in the object. If the emissivity is low and the object temperature relatively far from that of the reflected it will be important to set and compensate for the reflected apparent temperature correctly.

27.4 Distance

The distance is the distance between the object and the front lens of the camera. This parameter is used to compensate for the following two facts:

- That radiation from the target is absorbed by the atmosphere between the object and the camera.
- That radiation from the atmosphere itself is detected by the camera.

27.5 Relative humidity

The camera can also compensate for the fact that the transmittance is also dependent on the relative humidity of the atmosphere. To do this set the relative humidity to the correct value. For short distances and normal humidity the relative humidity can normally be left at a default value of 50%.

27.6 Other parameters

In addition, some cameras and analysis programs from FLIR Systems allow you to compensate for the following parameters:

- Atmospheric temperature – *i.e.* the temperature of the atmosphere between the camera and the target
- External optics temperature – *i.e.* the temperature of any external lenses or windows used in front of the camera
- External optics transmittance – *i.e.* the transmission of any external lenses or windows used in front of the camera

Before the year 1800, the existence of the infrared portion of the electromagnetic spectrum wasn't even suspected. The original significance of the infrared spectrum, or simply 'the infrared' as it is often called, as a form of heat radiation is perhaps less obvious today than it was at the time of its discovery by Herschel in 1800.



Figure 28.1 Sir William Herschel (1738–1822)

The discovery was made accidentally during the search for a new optical material. Sir William Herschel – Royal Astronomer to King George III of England, and already famous for his discovery of the planet Uranus – was searching for an optical filter material to reduce the brightness of the sun's image in telescopes during solar observations. While testing different samples of colored glass which gave similar reductions in brightness he was intrigued to find that some of the samples passed very little of the sun's heat, while others passed so much heat that he risked eye damage after only a few seconds' observation.

Herschel was soon convinced of the necessity of setting up a systematic experiment, with the objective of finding a single material that would give the desired reduction in brightness as well as the maximum reduction in heat. He began the experiment by actually repeating Newton's prism experiment, but looking for the heating effect rather than the visual distribution of intensity in the spectrum. He first blackened the bulb of a sensitive mercury-in-glass thermometer with ink, and with this as his radiation detector he proceeded to test the heating effect of the various colors of the spectrum formed on the top of a table by passing sunlight through a glass prism. Other thermometers, placed outside the sun's rays, served as controls.

As the blackened thermometer was moved slowly along the colors of the spectrum, the temperature readings showed a steady increase from the violet end to the red end. This was not entirely unexpected, since the Italian researcher, Landriani, in a similar experiment in 1777 had observed much the same effect. It was Herschel, however, who was the first to recognize that there must be a point where the heating effect reaches a maximum, and that measurements confined to the visible portion of the spectrum failed to locate this point.



Figure 28.2 Marsilio Landriani (1746–1815)

Moving the thermometer into the dark region beyond the red end of the spectrum, Herschel confirmed that the heating continued to increase. The maximum point, when he found it, lay well beyond the red end – in what is known today as the 'infrared wavelengths'.

When Herschel revealed his discovery, he referred to this new portion of the electromagnetic spectrum as the 'thermometrical spectrum'. The radiation itself he sometimes referred to as 'dark heat', or simply 'the invisible rays'. Ironically, and contrary to popular opinion, it wasn't Herschel who originated the term 'infrared'. The word only began to appear in print around 75 years later, and it is still unclear who should receive credit as the originator.

Herschel's use of glass in the prism of his original experiment led to some early controversies with his contemporaries about the actual existence of the infrared wavelengths. Different investigators, in attempting to confirm his work, used various types of glass indiscriminately, having different transparencies in the infrared. Through his later experiments, Herschel was aware of the limited transparency of glass to the newly-discovered thermal radiation, and he was forced to conclude that optics for the infrared would probably be doomed to the use of reflective elements exclusively (i.e. plane and curved mirrors). Fortunately, this proved to be true only until 1830, when the Italian investigator, Melloni, made his great discovery that naturally occurring rock salt (NaCl) – which was available in large enough natural crystals to be made into lenses and prisms – is remarkably transparent to the infrared. The result was that rock salt became the principal infrared optical material, and remained so for the next hundred years, until the art of synthetic crystal growing was mastered in the 1930's.



Figure 28.3 Macedonio Melloni (1798–1854)

Thermometers, as radiation detectors, remained unchallenged until 1829, the year Nobili invented the thermocouple. (Herschel's own thermometer could be read to $0.2\text{ }^{\circ}\text{C}$ ($0.036\text{ }^{\circ}\text{F}$), and later models were able to be read to $0.05\text{ }^{\circ}\text{C}$ ($0.09\text{ }^{\circ}\text{F}$)). Then a breakthrough occurred; Melloni connected a number of thermocouples in series to form the first thermopile. The new device was at least 40 times as sensitive as the best thermometer of the day for detecting heat radiation – capable of detecting the heat from a person standing three meters away.

The first so-called 'heat-picture' became possible in 1840, the result of work by Sir John Herschel, son of the discoverer of the infrared and a famous astronomer in his own right. Based upon the differential evaporation of a thin film of oil when exposed to a heat pattern focused upon it, the thermal image could be seen by reflected light where the interference effects of the oil film made the image visible to the eye. Sir John also managed to obtain a primitive record of the thermal image on paper, which he called a 'thermograph'.



Figure 28.4 Samuel P. Langley (1834–1906)

The improvement of infrared-detector sensitivity progressed slowly. Another major breakthrough, made by Langley in 1880, was the invention of the bolometer. This consisted of a thin blackened strip of platinum connected in one arm of a Wheatstone bridge circuit upon which the infrared radiation was focused and to which a sensitive galvanometer responded. This instrument is said to have been able to detect the heat from a cow at a distance of 400 meters.

An English scientist, Sir James Dewar, first introduced the use of liquefied gases as cooling agents (such as liquid nitrogen with a temperature of $-196\text{ }^{\circ}\text{C}$ ($-320.8\text{ }^{\circ}\text{F}$)) in low temperature research. In 1892 he invented a unique vacuum insulating container in which it is possible to store liquefied gases for entire days. The common 'thermos bottle', used for storing hot and cold drinks, is based upon his invention.

Between the years 1900 and 1920, the inventors of the world 'discovered' the infrared. Many patents were issued for devices to detect personnel, artillery, aircraft, ships – and even icebergs. The first operating systems, in the modern sense, began to be developed during the 1914–18 war, when both sides had research programs devoted to the military exploitation of the infrared. These programs included experimental systems for enemy intrusion/detection, remote temperature sensing, secure communications, and 'flying torpedo' guidance. An infrared search system tested during this period was able to detect an approaching airplane at a distance of 1.5 km (0.94 miles), or a person more than 300 meters (984 ft.) away.

The most sensitive systems up to this time were all based upon variations of the bolometer idea, but the period between the two wars saw the development of two revolutionary new infrared detectors: the image converter and the photon detector. At first, the image converter received the greatest attention by the military, because it enabled an observer for the first time in history to literally 'see in the dark'. However, the sensitivity of the image converter was limited to the near infrared wavelengths, and the most interesting military targets (i.e. enemy soldiers) had to be illuminated by infrared search beams. Since this involved the risk of giving away the observer's position to a similarly-equipped enemy observer, it is understandable that military interest in the image converter eventually faded.

The tactical military disadvantages of so-called 'active' (i.e. search beam-equipped) thermal imaging systems provided impetus following the 1939–45 war for extensive secret military infrared-research programs into the possibilities of developing 'passive' (no search beam) systems around the extremely sensitive photon detector. During this period, military secrecy regulations completely prevented disclosure of the status of infrared-imaging technology. This secrecy only began to be lifted in the middle of the 1950's, and from that time adequate thermal-imaging devices finally began to be available to civilian science and industry.

29.1 Introduction

The subjects of infrared radiation and the related technique of thermography are still new to many who will use an infrared camera. In this section the theory behind thermography will be given.

29.2 The electromagnetic spectrum

The electromagnetic spectrum is divided arbitrarily into a number of wavelength regions, called *bands*, distinguished by the methods used to produce and detect the radiation. There is no fundamental difference between radiation in the different bands of the electromagnetic spectrum. They are all governed by the same laws and the only differences are those due to differences in wavelength.

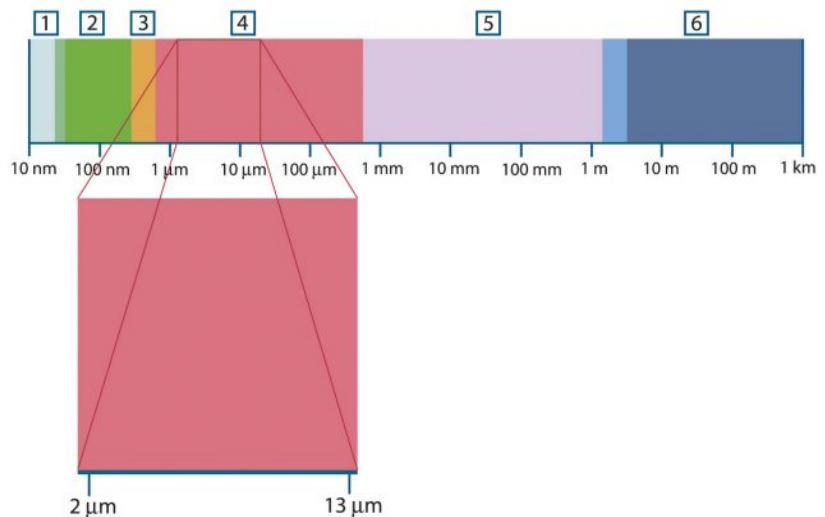

Figure 29.1 The electromagnetic spectrum. 1: X-ray; 2: UV; 3: Visible; 4: IR; 5: Microwaves; 6: Radiowaves.

Thermography makes use of the infrared spectral band. At the short-wavelength end the boundary lies at the limit of visual perception, in the deep red. At the long-wavelength end it merges with the microwave radio wavelengths, in the millimeter range.

The infrared band is often further subdivided into four smaller bands, the boundaries of which are also arbitrarily chosen. They include: the *near infrared* (0.75–3 μm), the *middle infrared* (3–6 μm), the *far infrared* (6–15 μm) and the *extreme infrared* (15–100 μm). Although the wavelengths are given in μm (micrometers), other units are often still used to measure wavelength in this spectral region, e.g. nanometer (nm) and Ångström (Å).

The relationships between the different wavelength measurements is:

$$10\,000\ \text{Å} = 1\,000\ \text{nm} = 1\ \mu = 1\ \mu\text{m}$$

29.3 Blackbody radiation

A blackbody is defined as an object which absorbs all radiation that impinges on it at any wavelength. The apparent misnomer *black* relating to an object emitting radiation is explained by Kirchhoff's Law (after *Gustav Robert Kirchhoff*, 1824–1887), which states that a body capable of absorbing all radiation at any wavelength is equally capable in the emission of radiation.

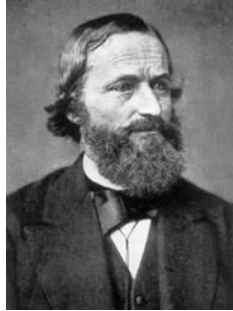

Figure 29.2 Gustav Robert Kirchhoff (1824–1887)

The construction of a blackbody source is, in principle, very simple. The radiation characteristics of an aperture in an isothermal cavity made of an opaque absorbing material represents almost exactly the properties of a blackbody. A practical application of the principle to the construction of a perfect absorber of radiation consists of a box that is light tight except for an aperture in one of the sides. Any radiation which then enters the hole is scattered and absorbed by repeated reflections so only an infinitesimal fraction can possibly escape. The blackness which is obtained at the aperture is nearly equal to a blackbody and almost perfect for all wavelengths.

By providing such an isothermal cavity with a suitable heater it becomes what is termed a *cavity radiator*. An isothermal cavity heated to a uniform temperature generates blackbody radiation, the characteristics of which are determined solely by the temperature of the cavity. Such cavity radiators are commonly used as sources of radiation in temperature reference standards in the laboratory for calibrating thermographic instruments, such as a FLIR Systems camera for example.

If the temperature of blackbody radiation increases to more than 525°C (977°F), the source begins to be visible so that it appears to the eye no longer black. This is the incipient red heat temperature of the radiator, which then becomes orange or yellow as the temperature increases further. In fact, the definition of the so-called *color temperature* of an object is the temperature to which a blackbody would have to be heated to have the same appearance.

Now consider three expressions that describe the radiation emitted from a blackbody.

29.3.1 Planck's law



Figure 29.3 Max Planck (1858–1947)

Max Planck (1858–1947) was able to describe the spectral distribution of the radiation from a blackbody by means of the following formula:

$$W_{\lambda b} = \frac{2\pi hc^2}{\lambda^5 \left(e^{\frac{hc}{\lambda kT}} - 1 \right)} \times 10^{-6} [\text{Watt} / \text{m}^2, \mu\text{m}]$$

where:

$W_{\lambda b}$	Blackbody spectral radiant emittance at wavelength λ .
c	Velocity of light = 3×10^8 m/s
h	Planck's constant = 6.6×10^{-34} Joule sec.
k	Boltzmann's constant = 1.4×10^{-23} Joule/K.
T	Absolute temperature (K) of a blackbody.
λ	Wavelength (μm).

Note The factor 10^{-6} is used since spectral emittance in the curves is expressed in $\text{Watt/m}^2, \mu\text{m}$.

Planck's formula, when plotted graphically for various temperatures, produces a family of curves. Following any particular Planck curve, the spectral emittance is zero at $\lambda = 0$, then increases rapidly to a maximum at a wavelength λ_{max} and after passing it approaches zero again at very long wavelengths. The higher the temperature, the shorter the wavelength at which maximum occurs.

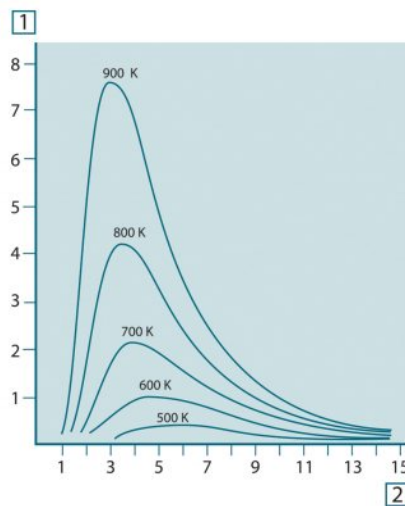

Figure 29.4 Blackbody spectral radiant emittance according to Planck's law, plotted for various absolute temperatures. 1: Spectral radiant emittance ($\text{W}/\text{cm}^2 \times 10^3(\mu\text{m})$); 2: Wavelength (μm)

29.3.2 Wien's displacement law

By differentiating Planck's formula with respect to λ , and finding the maximum, we have:

$$\lambda_{\text{max}} = \frac{2898}{T} [\mu\text{m}]$$

This is Wien's formula (after *Wilhelm Wien*, 1864–1928), which expresses mathematically the common observation that colors vary from red to orange or yellow as the temperature of a thermal radiator increases. The wavelength of the color is the same as the wavelength calculated for λ_{max} . A good approximation of the value of λ_{max} for a given blackbody temperature is obtained by applying the rule-of-thumb $3\,000/T \mu\text{m}$. Thus, a very hot star such as Sirius (11 000 K), emitting bluish-white light, radiates with the peak of spectral radiant emittance occurring within the invisible ultraviolet spectrum, at wavelength $0.27 \mu\text{m}$.



Figure 29.5 Wilhelm Wien (1864–1928)

The sun (approx. 6 000 K) emits yellow light, peaking at about 0.5 μm in the middle of the visible light spectrum.

At room temperature (300 K) the peak of radiant emittance lies at 9.7 μm , in the far infrared, while at the temperature of liquid nitrogen (77 K) the maximum of the almost insignificant amount of radiant emittance occurs at 38 μm , in the extreme infrared wavelengths.

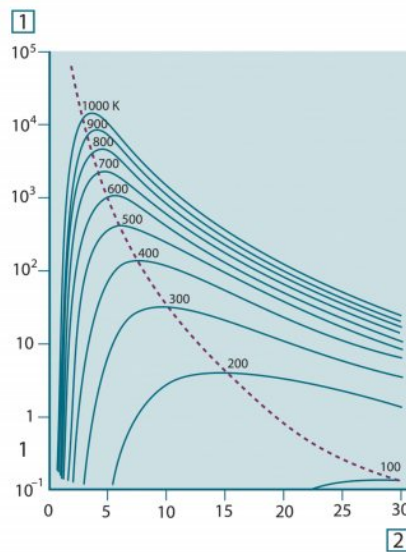

Figure 29.6 Planckian curves plotted on semi-log scales from 100 K to 1000 K. The dotted line represents the locus of maximum radiant emittance at each temperature as described by Wien's displacement law. 1: Spectral radiant emittance ($\text{W}/\text{cm}^2 (\mu\text{m})$); 2: Wavelength (μm).

29.3.3 Stefan-Boltzmann's law

By integrating Planck's formula from $\lambda = 0$ to $\lambda = \infty$, we obtain the total radiant emittance (W_b) of a blackbody:

$$W_b = \sigma T^4 \quad [\text{Watt}/\text{m}^2]$$

This is the Stefan-Boltzmann formula (after *Josef Stefan*, 1835–1893, and *Ludwig Boltzmann*, 1844–1906), which states that the total emissive power of a blackbody is proportional to the fourth power of its absolute temperature. Graphically, W_b represents the area below the Planck curve for a particular temperature. It can be shown that the radiant emittance in the interval $\lambda = 0$ to λ_{max} is only 25% of the total, which represents about the amount of the sun's radiation which lies inside the visible light spectrum.



Figure 29.7 Josef Stefan (1835–1893), and Ludwig Boltzmann (1844–1906)

Using the Stefan-Boltzmann formula to calculate the power radiated by the human body, at a temperature of 300 K and an external surface area of approx. 2 m², we obtain 1 kW. This power loss could not be sustained if it were not for the compensating absorption of radiation from surrounding surfaces, at room temperatures which do not vary too drastically from the temperature of the body – or, of course, the addition of clothing.

29.3.4 Non-blackbody emitters

So far, only blackbody radiators and blackbody radiation have been discussed. However, real objects almost never comply with these laws over an extended wavelength region – although they may approach the blackbody behavior in certain spectral intervals. For example, a certain type of white paint may appear perfectly *white* in the visible light spectrum, but becomes distinctly *gray* at about 2 μm, and beyond 3 μm it is almost *black*.

There are three processes which can occur that prevent a real object from acting like a blackbody: a fraction of the incident radiation α may be absorbed, a fraction ρ may be reflected, and a fraction τ may be transmitted. Since all of these factors are more or less wavelength dependent, the subscript λ is used to imply the spectral dependence of their definitions. Thus:

- The spectral absorptance α_λ = the ratio of the spectral radiant power absorbed by an object to that incident upon it.
- The spectral reflectance ρ_λ = the ratio of the spectral radiant power reflected by an object to that incident upon it.
- The spectral transmittance τ_λ = the ratio of the spectral radiant power transmitted through an object to that incident upon it.

The sum of these three factors must always add up to the whole at any wavelength, so we have the relation:

$$\alpha_\lambda + \rho_\lambda + \tau_\lambda = 1$$

For opaque materials $\tau_\lambda = 0$ and the relation simplifies to:

$$\alpha_\lambda + \rho_\lambda = 1$$

Another factor, called the emissivity, is required to describe the fraction ε of the radiant emittance of a blackbody produced by an object at a specific temperature. Thus, we have the definition:

The spectral emissivity ε_λ = the ratio of the spectral radiant power from an object to that from a blackbody at the same temperature and wavelength.

Expressed mathematically, this can be written as the ratio of the spectral emittance of the object to that of a blackbody as follows:

$$\varepsilon_\lambda = \frac{W_{\lambda o}}{W_{\lambda b}}$$

Generally speaking, there are three types of radiation source, distinguished by the ways in which the spectral emittance of each varies with wavelength.

- A blackbody, for which $\varepsilon_\lambda = \varepsilon = 1$
- A graybody, for which $\varepsilon_\lambda = \varepsilon = \text{constant less than 1}$

- A selective radiator, for which ε varies with wavelength

According to Kirchhoff's law, for any material the spectral emissivity and spectral absorptance of a body are equal at any specified temperature and wavelength. That is:

$$\varepsilon_{\lambda} = \alpha_{\lambda}$$

From this we obtain, for an opaque material (since $\alpha_{\lambda} + \rho_{\lambda} = 1$):

$$\varepsilon_{\lambda} + \rho_{\lambda} = 1$$

For highly polished materials ε_{λ} approaches zero, so that for a perfectly reflecting material (*i.e.* a perfect mirror) we have:

$$\rho_{\lambda} = 1$$

For a graybody radiator, the Stefan-Boltzmann formula becomes:

$$W = \varepsilon \sigma T^4 \text{ [Watt/m}^2\text{]}$$

This states that the total emissive power of a graybody is the same as a blackbody at the same temperature reduced in proportion to the value of ε from the graybody.

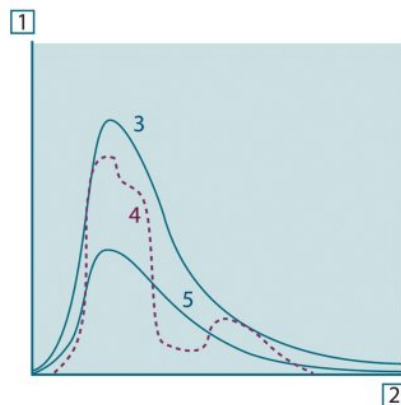

Figure 29.8 Spectral radiant emittance of three types of radiators. 1: Spectral radiant emittance; 2: Wavelength; 3: Blackbody; 4: Selective radiator; 5: Graybody.

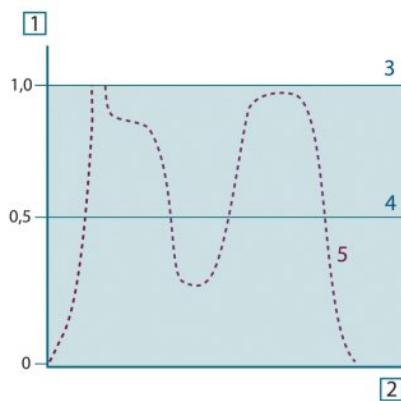

Figure 29.9 Spectral emissivity of three types of radiators. 1: Spectral emissivity; 2: Wavelength; 3: Blackbody; 4: Graybody; 5: Selective radiator.

29.4 Infrared semi-transparent materials

Consider now a non-metallic, semi-transparent body – let us say, in the form of a thick flat plate of plastic material. When the plate is heated, radiation generated within its volume must work its way toward the surfaces through the material in which it is partially absorbed. Moreover, when it arrives at the surface, some of it is reflected back into the interior. The back-reflected radiation is again partially absorbed, but some of it arrives at the other surface, through which most of it escapes; part of it is reflected back again. Although the progressive reflections become weaker and weaker they must all be added up when the total emittance of the plate is sought. When the resulting geometrical series is summed, the effective emissivity of a semi-transparent plate is obtained as:

$$\varepsilon_{\lambda} = \frac{(1 - \rho_{\lambda})(1 - \tau_{\lambda})}{1 - \rho_{\lambda}\tau_{\lambda}}$$

When the plate becomes opaque this formula is reduced to the single formula:

$$\varepsilon_{\lambda} = 1 - \rho_{\lambda}$$

This last relation is a particularly convenient one, because it is often easier to measure reflectance than to measure emissivity directly.

As already mentioned, when viewing an object, the camera receives radiation not only from the object itself. It also collects radiation from the surroundings reflected via the object surface. Both these radiation contributions become attenuated to some extent by the atmosphere in the measurement path. To this comes a third radiation contribution from the atmosphere itself.

This description of the measurement situation, as illustrated in the figure below, is so far a fairly true description of the real conditions. What has been neglected could for instance be sun light scattering in the atmosphere or stray radiation from intense radiation sources outside the field of view. Such disturbances are difficult to quantify, however, in most cases they are fortunately small enough to be neglected. In case they are not negligible, the measurement configuration is likely to be such that the risk for disturbance is obvious, at least to a trained operator. It is then his responsibility to modify the measurement situation to avoid the disturbance e.g. by changing the viewing direction, shielding off intense radiation sources etc.

Accepting the description above, we can use the figure below to derive a formula for the calculation of the object temperature from the calibrated camera output.

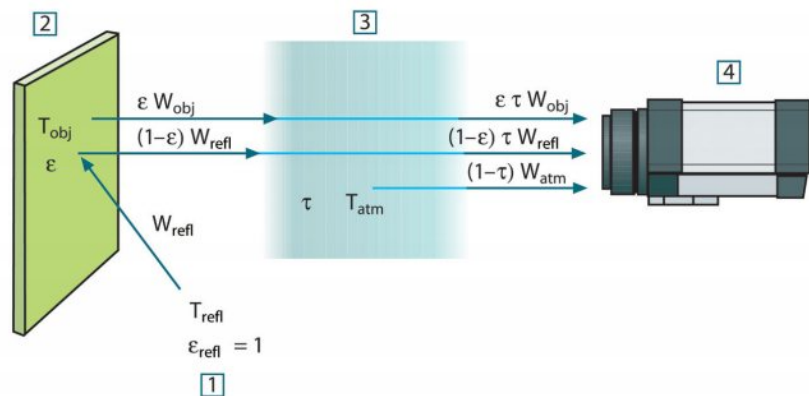

Figure 30.1 A schematic representation of the general thermographic measurement situation. 1: Surroundings; 2: Object; 3: Atmosphere; 4: Camera

Assume that the received radiation power W from a blackbody source of temperature T_{source} on short distance generates a camera output signal U_{source} that is proportional to the power input (power linear camera). We can then write (Equation 1):

$$U_{\text{source}} = CW(T_{\text{source}})$$

or, with simplified notation:

$$U_{\text{source}} = CW_{\text{source}}$$

where C is a constant.

Should the source be a graybody with emittance ϵ , the received radiation would consequently be $\epsilon W_{\text{source}}$.

We are now ready to write the three collected radiation power terms:

1. *Emission from the object* = $\epsilon \tau W_{\text{obj}}$, where ϵ is the emittance of the object and τ is the transmittance of the atmosphere. The object temperature is T_{obj} .

2. *Reflected emission from ambient sources* = $(1 - \varepsilon)\tau W_{\text{refl}}$, where $(1 - \varepsilon)$ is the reflectance of the object. The ambient sources have the temperature T_{refl} .

It has here been assumed that the temperature T_{refl} is the same for all emitting surfaces within the halfsphere seen from a point on the object surface. This is of course sometimes a simplification of the true situation. It is, however, a necessary simplification in order to derive a workable formula, and T_{refl} can – at least theoretically – be given a value that represents an efficient temperature of a complex surrounding.

Note also that we have assumed that the emittance for the surroundings = 1. This is correct in accordance with Kirchhoff's law: All radiation impinging on the surrounding surfaces will eventually be absorbed by the same surfaces. Thus the emittance = 1. (Note though that the latest discussion requires the complete sphere around the object to be considered.)

3. *Emission from the atmosphere* = $(1 - \tau)\tau W_{\text{atm}}$, where $(1 - \tau)$ is the emittance of the atmosphere. The temperature of the atmosphere is T_{atm} .

The total received radiation power can now be written (Equation 2):

$$W_{\text{tot}} = \varepsilon\tau W_{\text{obj}} + (1 - \varepsilon)\tau W_{\text{refl}} + (1 - \tau)W_{\text{atm}}$$

We multiply each term by the constant C of Equation 1 and replace the CW products by the corresponding U according to the same equation, and get (Equation 3):

$$U_{\text{tot}} = \varepsilon\tau U_{\text{obj}} + (1 - \varepsilon)\tau U_{\text{refl}} + (1 - \tau)U_{\text{atm}}$$

Solve Equation 3 for U_{obj} (Equation 4):

$$U_{\text{obj}} = \frac{1}{\varepsilon\tau} U_{\text{tot}} - \frac{1 - \varepsilon}{\varepsilon} U_{\text{refl}} - \frac{1 - \tau}{\varepsilon\tau} U_{\text{atm}}$$

This is the general measurement formula used in all the FLIR Systems thermographic equipment. The variables of the formula are:

Table 30.1 Voltages

U_{obj}	Calculated camera output voltage for a blackbody of temperature T_{obj} i.e. a voltage that can be directly converted into true requested object temperature.
U_{tot}	Measured camera output voltage for the actual case.
U_{refl}	Theoretical camera output voltage for a blackbody of temperature T_{refl} according to the calibration.
U_{atm}	Theoretical camera output voltage for a blackbody of temperature T_{atm} according to the calibration.

The operator has to supply a number of parameter values for the calculation:

- the object emittance ε ,
- the relative humidity,
- T_{atm}
- object distance (D_{obj})
- the (effective) temperature of the object surroundings, or the reflected ambient temperature T_{refl} , and
- the temperature of the atmosphere T_{atm}

This task could sometimes be a heavy burden for the operator since there are normally no easy ways to find accurate values of emittance and atmospheric transmittance for the actual case. The two temperatures are normally less of a problem provided the surroundings do not contain large and intense radiation sources.

A natural question in this connection is: How important is it to know the right values of these parameters? It could though be of interest to get a feeling for this problem already here by looking into some different measurement cases and compare the relative

magnitudes of the three radiation terms. This will give indications about when it is important to use correct values of which parameters.

The figures below illustrates the relative magnitudes of the three radiation contributions for three different object temperatures, two emittances, and two spectral ranges: SW and LW. Remaining parameters have the following fixed values:

- $\tau = 0.88$
- $T_{\text{refl}} = +20^{\circ}\text{C} (+68^{\circ}\text{F})$
- $T_{\text{atm}} = +20^{\circ}\text{C} (+68^{\circ}\text{F})$

It is obvious that measurement of low object temperatures are more critical than measuring high temperatures since the ‘disturbing’ radiation sources are relatively much stronger in the first case. Should also the object emittance be low, the situation would be still more difficult.

We have finally to answer a question about the importance of being allowed to use the calibration curve above the highest calibration point, what we call extrapolation. Imagine that we in a certain case measure $U_{\text{tot}} = 4.5$ volts. The highest calibration point for the camera was in the order of 4.1 volts, a value unknown to the operator. Thus, even if the object happened to be a blackbody, i.e. $U_{\text{obj}} = U_{\text{tot}}$, we are actually performing extrapolation of the calibration curve when converting 4.5 volts into temperature.

Let us now assume that the object is not black, it has an emittance of 0.75, and the transmittance is 0.92. We also assume that the two second terms of Equation 4 amount to 0.5 volts together. Computation of U_{obj} by means of Equation 4 then results in $U_{\text{obj}} = 4.5 / 0.75 / 0.92 - 0.5 = 6.0$. This is a rather extreme extrapolation, particularly when considering that the video amplifier might limit the output to 5 volts! Note, though, that the application of the calibration curve is a theoretical procedure where no electronic or other limitations exist. We trust that if there had been no signal limitations in the camera, and if it had been calibrated far beyond 5 volts, the resulting curve would have been very much the same as our real curve extrapolated beyond 4.1 volts, provided the calibration algorithm is based on radiation physics, like the FLIR Systems algorithm. Of course there must be a limit to such extrapolations.

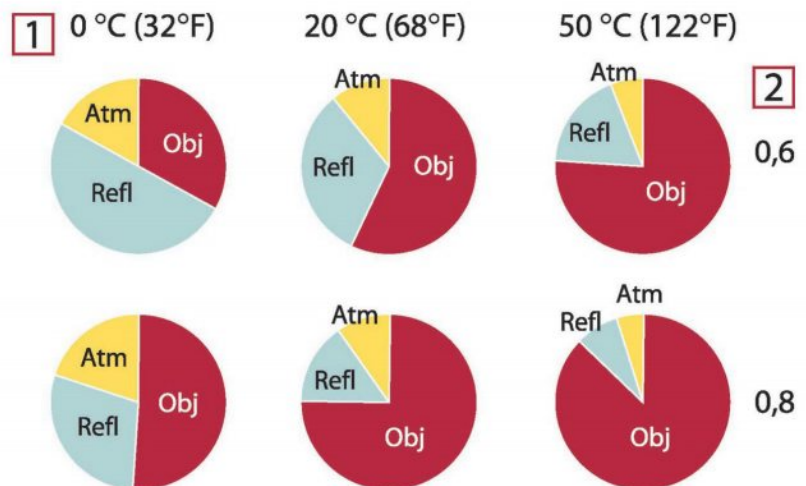

Figure 30.2 Relative magnitudes of radiation sources under varying measurement conditions (SW camera). 1: Object temperature; 2: Emittance; Obj: Object radiation; Refl: Reflected radiation; Atm: atmosphere radiation. Fixed parameters: $\tau = 0.88$; $T_{\text{refl}} = 20^{\circ}\text{C} (+68^{\circ}\text{F})$; $T_{\text{atm}} = 20^{\circ}\text{C} (+68^{\circ}\text{F})$.

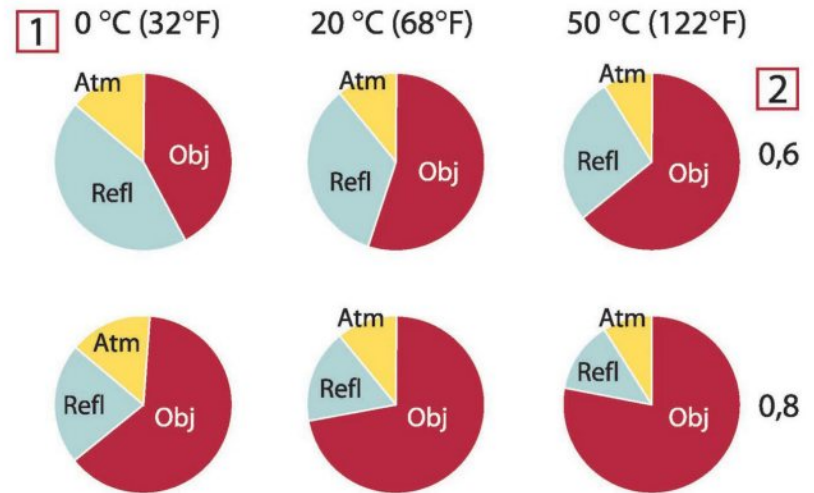

Figure 30.3 Relative magnitudes of radiation sources under varying measurement conditions (LW camera). 1: Object temperature; 2: Emittance; Obj: Object radiation; Refl: Reflected radiation; Atm: atmosphere radiation. Fixed parameters: $\tau = 0.88$; $T_{\text{refl}} = 20^{\circ}\text{C}$ (+68°F); $T_{\text{atm}} = 20^{\circ}\text{C}$ (+68°F).

This section presents a compilation of emissivity data from the infrared literature and measurements made by FLIR Systems.

31.1 References

1. Mikael A. Bramson: *Infrared Radiation, A Handbook for Applications*, Plenum press, N.Y.
2. William L. Wolfe, George J. Zissis: *The Infrared Handbook*, Office of Naval Research, Department of Navy, Washington, D.C.
3. Madding, R. P.: *Thermographic Instruments and systems*. Madison, Wisconsin: University of Wisconsin – Extension, Department of Engineering and Applied Science.
4. William L. Wolfe: *Handbook of Military Infrared Technology*, Office of Naval Research, Department of Navy, Washington, D.C.
5. Jones, Smith, Probert: *External thermography of buildings...*, Proc. of the Society of Photo-Optical Instrumentation Engineers, vol.110, Industrial and Civil Applications of Infrared Technology, June 1977 London.
6. Paljak, Pettersson: *Thermography of Buildings*, Swedish Building Research Institute, Stockholm 1972.
7. Vlcek, J: *Determination of emissivity with imaging radiometers and some emissivities at $\lambda = 5 \mu\text{m}$* . Photogrammetric Engineering and Remote Sensing.
8. Kern: *Evaluation of infrared emission of clouds and ground as measured by weather satellites*, Defence Documentation Center, AD 617 417.
9. Öhman, Claes: *Emittansmätningar med AGEMA E-Box*. Teknisk rapport, AGEMA 1999. (Emittance measurements using AGEMA E-Box. Technical report, AGEMA 1999.)
10. Mattei, S., Tang-Kwor, E: *Emissivity measurements for Nextel Velvet coating 811-21 between -36°C AND 82°C* .
11. Lohrengel & Todtenhaupt (1996)
12. ITC Technical publication 32.
13. ITC Technical publication 29.
14. Schuster, Norbert and Kolobrodov, Valentin G. *Infrarotthermographie*. Berlin: Wiley-VCH, 2000.

Note The emissivity values in the table below are recorded using a shortwave (SW) camera. The values should be regarded as recommendations only and used with caution.

31.2 Tables

Table 31.1 T: Total spectrum; SW: 2–5 μm ; LW: 8–14 μm , LLW: 6.5–20 μm ; 1: Material; 2: Specification; 3: Temperature in $^{\circ}\text{C}$; 4: Spectrum; 5: Emissivity; 6: Reference

1	2	3	4	5	6
3M type 35	Vinyl electrical tape (several colors)	< 80	LW	≈ 0.96	13
3M type 88	Black vinyl electrical tape	< 105	LW	≈ 0.96	13
3M type 88	Black vinyl electrical tape	< 105	MW	< 0.96	13
3M type Super 33+	Black vinyl electrical tape	< 80	LW	≈ 0.96	13
Aluminum	anodized sheet	100	T	0.55	2
Aluminum	anodized, black, dull	70	SW	0.67	9
Aluminum	anodized, black, dull	70	LW	0.95	9

Table 31.1 T: Total spectrum; SW: 2–5 μm ; LW: 8–14 μm , LLW: 6.5–20 μm ; 1: Material; 2: Specification; 3: Temperature in $^{\circ}\text{C}$; 4: Spectrum; 5: Emissivity; 6: Reference (continued)

1	2	3	4	5	6
Aluminum	anodized, light gray, dull	70	SW	0.61	9
Aluminum	anodized, light gray, dull	70	LW	0.97	9
Aluminum	as received, plate	100	T	0.09	4
Aluminum	as received, sheet	100	T	0.09	2
Aluminum	cast, blast cleaned	70	SW	0.47	9
Aluminum	cast, blast cleaned	70	LW	0.46	9
Aluminum	dipped in HNO_3 , plate	100	T	0.05	4
Aluminum	foil	27	10 μm	0.04	3
Aluminum	foil	27	3 μm	0.09	3
Aluminum	oxidized, strongly	50–500	T	0.2–0.3	1
Aluminum	polished	50–100	T	0.04–0.06	1
Aluminum	polished plate	100	T	0.05	4
Aluminum	polished, sheet	100	T	0.05	2
Aluminum	rough surface	20–50	T	0.06–0.07	1
Aluminum	roughened	27	10 μm	0.18	3
Aluminum	roughened	27	3 μm	0.28	3
Aluminum	sheet, 4 samples differently scratched	70	SW	0.05–0.08	9
Aluminum	sheet, 4 samples differently scratched	70	LW	0.03–0.06	9
Aluminum	vacuum deposited	20	T	0.04	2
Aluminum	weathered, heavily	17	SW	0.83–0.94	5
Aluminum bronze		20	T	0.60	1
Aluminum hydroxide	powder		T	0.28	1
Aluminum oxide	activated, powder		T	0.46	1
Aluminum oxide	pure, powder (alumina)		T	0.16	1
Asbestos	board	20	T	0.96	1
Asbestos	fabric		T	0.78	1
Asbestos	floor tile	35	SW	0.94	7
Asbestos	paper	40–400	T	0.93–0.95	1
Asbestos	powder		T	0.40–0.60	1
Asbestos	slate	20	T	0.96	1
Asphalt paving		4	LLW	0.967	8
Brass	dull, tarnished	20–350	T	0.22	1
Brass	oxidized	100	T	0.61	2
Brass	oxidized	70	SW	0.04–0.09	9

Table 31.1 T: Total spectrum; SW: 2–5 µm; LW: 8–14 µm, LLW: 6.5–20 µm; 1: Material; 2: Specification; 3: Temperature in °C; 4: Spectrum; 5: Emissivity; 6: Reference (continued)

1	2	3	4	5	6
Brass	oxidized	70	LW	0.03–0.07	9
Brass	oxidized at 600°C	200–600	T	0.59–0.61	1
Brass	polished	200	T	0.03	1
Brass	polished, highly	100	T	0.03	2
Brass	rubbed with 80-grit emery	20	T	0.20	2
Brass	sheet, rolled	20	T	0.06	1
Brass	sheet, worked with emery	20	T	0.2	1
Brick	alumina	17	SW	0.68	5
Brick	common	17	SW	0.86–0.81	5
Brick	Dinas silica, glazed, rough	1100	T	0.85	1
Brick	Dinas silica, refractory	1000	T	0.66	1
Brick	Dinas silica, unglazed, rough	1000	T	0.80	1
Brick	firebrick	17	SW	0.68	5
Brick	fireclay	1000	T	0.75	1
Brick	fireclay	1200	T	0.59	1
Brick	fireclay	20	T	0.85	1
Brick	masonry	35	SW	0.94	7
Brick	masonry, plastered	20	T	0.94	1
Brick	red, common	20	T	0.93	2
Brick	red, rough	20	T	0.88–0.93	1
Brick	refractory, corundum	1000	T	0.46	1
Brick	refractory, magnesite	1000–1300	T	0.38	1
Brick	refractory, strongly radiating	500–1000	T	0.8–0.9	1
Brick	refractory, weakly radiating	500–1000	T	0.65–0.75	1
Brick	silica, 95% SiO ₂	1230	T	0.66	1
Brick	sillimanite, 33% SiO ₂ , 64% Al ₂ O ₃	1500	T	0.29	1
Brick	waterproof	17	SW	0.87	5
Bronze	phosphor bronze	70	SW	0.08	9
Bronze	phosphor bronze	70	LW	0.06	9
Bronze	polished	50	T	0.1	1
Bronze	porous, rough	50–150	T	0.55	1
Bronze	powder		T	0.76–0.80	1
Carbon	candle soot	20	T	0.95	2
Carbon	charcoal powder		T	0.96	1
Carbon	graphite powder		T	0.97	1

Table 31.1 T: Total spectrum; SW: 2–5 µm; LW: 8–14 µm, LLW: 6.5–20 µm; 1: Material; 2: Specification; 3: Temperature in °C; 4: Spectrum; 5: Emissivity; 6: Reference (continued)

1	2	3	4	5	6
Carbon	graphite, filed surface	20	T	0.98	2
Carbon	lampblack	20–400	T	0.95–0.97	1
Chipboard	untreated	20	SW	0.90	6
Chromium	polished	50	T	0.10	1
Chromium	polished	500–1000	T	0.28–0.38	1
Clay	fired	70	T	0.91	1
Cloth	black	20	T	0.98	1
Concrete		20	T	0.92	2
Concrete	dry	36	SW	0.95	7
Concrete	rough	17	SW	0.97	5
Concrete	walkway	5	LLW	0.974	8
Copper	commercial, burnished	20	T	0.07	1
Copper	electrolytic, carefully polished	80	T	0.018	1
Copper	electrolytic, polished	–34	T	0.006	4
Copper	molten	1100–1300	T	0.13–0.15	1
Copper	oxidized	50	T	0.6–0.7	1
Copper	oxidized to blackness		T	0.88	1
Copper	oxidized, black	27	T	0.78	4
Copper	oxidized, heavily	20	T	0.78	2
Copper	polished	50–100	T	0.02	1
Copper	polished	100	T	0.03	2
Copper	polished, commercial	27	T	0.03	4
Copper	polished, mechanical	22	T	0.015	4
Copper	pure, carefully prepared surface	22	T	0.008	4
Copper	scraped	27	T	0.07	4
Copper dioxide	powder		T	0.84	1
Copper oxide	red, powder		T	0.70	1
Ebonite			T	0.89	1
Emery	coarse	80	T	0.85	1
Enamel		20	T	0.9	1
Enamel	lacquer	20	T	0.85–0.95	1
Fiber board	hard, untreated	20	SW	0.85	6
Fiber board	masonite	70	SW	0.75	9
Fiber board	masonite	70	LW	0.88	9
Fiber board	particle board	70	SW	0.77	9
Fiber board	particle board	70	LW	0.89	9
Fiber board	porous, untreated	20	SW	0.85	6

Table 31.1 T: Total spectrum; SW: 2–5 µm; LW: 8–14 µm, LLW: 6.5–20 µm; 1: Material; 2: Specification; 3: Temperature in °C; 4: Spectrum; 5: Emissivity; 6: Reference (continued)

1	2	3	4	5	6
Glass pane (float glass)	non-coated	20	LW	0.97	14
Gold	polished	130	T	0.018	1
Gold	polished, carefully	200–600	T	0.02–0.03	1
Gold	polished, highly	100	T	0.02	2
Granite	polished	20	LLW	0.849	8
Granite	rough	21	LLW	0.879	8
Granite	rough, 4 different samples	70	SW	0.95–0.97	9
Granite	rough, 4 different samples	70	LW	0.77–0.87	9
Gypsum		20	T	0.8–0.9	1
Ice: See Water					
Iron and steel	cold rolled	70	SW	0.20	9
Iron and steel	cold rolled	70	LW	0.09	9
Iron and steel	covered with red rust	20	T	0.61–0.85	1
Iron and steel	electrolytic	100	T	0.05	4
Iron and steel	electrolytic	22	T	0.05	4
Iron and steel	electrolytic	260	T	0.07	4
Iron and steel	electrolytic, carefully polished	175–225	T	0.05–0.06	1
Iron and steel	freshly worked with emery	20	T	0.24	1
Iron and steel	ground sheet	950–1100	T	0.55–0.61	1
Iron and steel	heavily rusted sheet	20	T	0.69	2
Iron and steel	hot rolled	130	T	0.60	1
Iron and steel	hot rolled	20	T	0.77	1
Iron and steel	oxidized	100	T	0.74	4
Iron and steel	oxidized	100	T	0.74	1
Iron and steel	oxidized	1227	T	0.89	4
Iron and steel	oxidized	125–525	T	0.78–0.82	1
Iron and steel	oxidized	200	T	0.79	2
Iron and steel	oxidized	200–600	T	0.80	1
Iron and steel	oxidized strongly	50	T	0.88	1
Iron and steel	oxidized strongly	500	T	0.98	1
Iron and steel	polished	100	T	0.07	2
Iron and steel	polished	400–1000	T	0.14–0.38	1
Iron and steel	polished sheet	750–1050	T	0.52–0.56	1
Iron and steel	rolled sheet	50	T	0.56	1
Iron and steel	rolled, freshly	20	T	0.24	1
Iron and steel	rough, plane surface	50	T	0.95–0.98	1
Iron and steel	rusted red, sheet	22	T	0.69	4
Iron and steel	rusted, heavily	17	SW	0.96	5

Table 31.1 T: Total spectrum; SW: 2–5 μm; LW: 8–14 μm, LLW: 6.5–20 μm; 1: Material; 2: Specification; 3: Temperature in °C; 4: Spectrum; 5: Emissivity; 6: Reference (continued)

1	2	3	4	5	6
Iron and steel	rusty, red	20	T	0.69	1
Iron and steel	shiny oxide layer, sheet,	20	T	0.82	1
Iron and steel	shiny, etched	150	T	0.16	1
Iron and steel	wrought, carefully polished	40–250	T	0.28	1
Iron galvanized	heavily oxidized	70	SW	0.64	9
Iron galvanized	heavily oxidized	70	LW	0.85	9
Iron galvanized	sheet	92	T	0.07	4
Iron galvanized	sheet, burnished	30	T	0.23	1
Iron galvanized	sheet, oxidized	20	T	0.28	1
Iron tinned	sheet	24	T	0.064	4
Iron, cast	casting	50	T	0.81	1
Iron, cast	ingots	1000	T	0.95	1
Iron, cast	liquid	1300	T	0.28	1
Iron, cast	machined	800–1000	T	0.60–0.70	1
Iron, cast	oxidized	100	T	0.64	2
Iron, cast	oxidized	260	T	0.66	4
Iron, cast	oxidized	38	T	0.63	4
Iron, cast	oxidized	538	T	0.76	4
Iron, cast	oxidized at 600°C	200–600	T	0.64–0.78	1
Iron, cast	polished	200	T	0.21	1
Iron, cast	polished	38	T	0.21	4
Iron, cast	polished	40	T	0.21	2
Iron, cast	unworked	900–1100	T	0.87–0.95	1
Krylon Ultra-flat black 1602	Flat black	Room temperature up to 175	LW	≈ 0.96	12
Krylon Ultra-flat black 1602	Flat black	Room temperature up to 175	MW	≈ 0.97	12
Lacquer	3 colors sprayed on Aluminum	70	SW	0.50–0.53	9
Lacquer	3 colors sprayed on Aluminum	70	LW	0.92–0.94	9
Lacquer	Aluminum on rough surface	20	T	0.4	1
Lacquer	bakelite	80	T	0.83	1
Lacquer	black, dull	40–100	T	0.96–0.98	1
Lacquer	black, matte	100	T	0.97	2
Lacquer	black, shiny, sprayed on iron	20	T	0.87	1
Lacquer	heat-resistant	100	T	0.92	1
Lacquer	white	100	T	0.92	2
Lacquer	white	40–100	T	0.8–0.95	1
Lead	oxidized at 200°C	200	T	0.63	1
Lead	oxidized, gray	20	T	0.28	1

Table 31.1 T: Total spectrum; SW: 2–5 µm; LW: 8–14 µm, LLW: 6.5–20 µm; 1: Material; 2: Specification; 3: Temperature in °C; 4: Spectrum; 5: Emissivity; 6: Reference (continued)

1	2	3	4	5	6
Lead	oxidized, gray	22	T	0.28	4
Lead	shiny	250	T	0.08	1
Lead	unoxidized, polished	100	T	0.05	4
Lead red		100	T	0.93	4
Lead red, powder		100	T	0.93	1
Leather	tanned		T	0.75–0.80	1
Lime			T	0.3–0.4	1
Magnesium		22	T	0.07	4
Magnesium		260	T	0.13	4
Magnesium		538	T	0.18	4
Magnesium	polished	20	T	0.07	2
Magnesium powder			T	0.86	1
Molybdenum		1500–2200	T	0.19–0.26	1
Molybdenum		600–1000	T	0.08–0.13	1
Molybdenum	filament	700–2500	T	0.1–0.3	1
Mortar		17	SW	0.87	5
Mortar	dry	36	SW	0.94	7
Nextel Velvet 811-21 Black	Flat black	–60–150	LW	> 0.97	10 and 11
Nichrome	rolled	700	T	0.25	1
Nichrome	sandblasted	700	T	0.70	1
Nichrome	wire, clean	50	T	0.65	1
Nichrome	wire, clean	500–1000	T	0.71–0.79	1
Nichrome	wire, oxidized	50–500	T	0.95–0.98	1
Nickel	bright matte	122	T	0.041	4
Nickel	commercially pure, polished	100	T	0.045	1
Nickel	commercially pure, polished	200–400	T	0.07–0.09	1
Nickel	electrolytic	22	T	0.04	4
Nickel	electrolytic	260	T	0.07	4
Nickel	electrolytic	38	T	0.06	4
Nickel	electrolytic	538	T	0.10	4
Nickel	electroplated on iron, polished	22	T	0.045	4
Nickel	electroplated on iron, unpolished	20	T	0.11–0.40	1
Nickel	electroplated on iron, unpolished	22	T	0.11	4
Nickel	electroplated, polished	20	T	0.05	2
Nickel	oxidized	1227	T	0.85	4
Nickel	oxidized	200	T	0.37	2
Nickel	oxidized	227	T	0.37	4

Table 31.1 T: Total spectrum; SW: 2–5 µm; LW: 8–14 µm, LLW: 6.5–20 µm; 1: Material; 2: Specification; 3: Temperature in °C; 4: Spectrum; 5: Emissivity; 6: Reference (continued)

1	2	3	4	5	6
Nickel	oxidized at 600°C	200–600	T	0.37–0.48	1
Nickel	polished	122	T	0.045	4
Nickel	wire	200–1000	T	0.1–0.2	1
Nickel oxide		1000–1250	T	0.75–0.86	1
Nickel oxide		500–650	T	0.52–0.59	1
Oil, lubricating	0.025 mm film	20	T	0.27	2
Oil, lubricating	0.050 mm film	20	T	0.46	2
Oil, lubricating	0.125 mm film	20	T	0.72	2
Oil, lubricating	film on Ni base: Ni base only	20	T	0.05	2
Oil, lubricating	thick coating	20	T	0.82	2
Paint	8 different colors and qualities	70	SW	0.88–0.96	9
Paint	8 different colors and qualities	70	LW	0.92–0.94	9
Paint	Aluminum, vari- ous ages	50–100	T	0.27–0.67	1
Paint	cadmium yellow		T	0.28–0.33	1
Paint	chrome green		T	0.65–0.70	1
Paint	cobalt blue		T	0.7–0.8	1
Paint	oil	17	SW	0.87	5
Paint	oil based, aver- age of 16 colors	100	T	0.94	2
Paint	oil, black flat	20	SW	0.94	6
Paint	oil, black gloss	20	SW	0.92	6
Paint	oil, gray flat	20	SW	0.97	6
Paint	oil, gray gloss	20	SW	0.96	6
Paint	oil, various colors	100	T	0.92–0.96	1
Paint	plastic, black	20	SW	0.95	6
Paint	plastic, white	20	SW	0.84	6
Paper	4 different colors	70	SW	0.68–0.74	9
Paper	4 different colors	70	LW	0.92–0.94	9
Paper	black		T	0.90	1
Paper	black, dull		T	0.94	1
Paper	black, dull	70	SW	0.86	9
Paper	black, dull	70	LW	0.89	9
Paper	blue, dark		T	0.84	1
Paper	coated with black lacquer		T	0.93	1
Paper	green		T	0.85	1
Paper	red		T	0.76	1
Paper	white	20	T	0.7–0.9	1
Paper	white bond	20	T	0.93	2
Paper	white, 3 different glosses	70	SW	0.76–0.78	9

Table 31.1 T: Total spectrum; SW: 2–5 µm; LW: 8–14 µm, LLW: 6.5–20 µm; 1: Material; 2: Specification; 3: Temperature in °C; 4: Spectrum; 5: Emissivity; 6: Reference (continued)

1	2	3	4	5	6
Paper	white, 3 different glosses	70	LW	0.88–0.90	9
Paper	yellow		T	0.72	1
Plaster		17	SW	0.86	5
Plaster	plasterboard, untreated	20	SW	0.90	6
Plaster	rough coat	20	T	0.91	2
Plastic	glass fibre laminate (printed circ. board)	70	SW	0.94	9
Plastic	glass fibre laminate (printed circ. board)	70	LW	0.91	9
Plastic	polyurethane isolation board	70	LW	0.55	9
Plastic	polyurethane isolation board	70	SW	0.29	9
Plastic	PVC, plastic floor, dull, structured	70	SW	0.94	9
Plastic	PVC, plastic floor, dull, structured	70	LW	0.93	9
Platinum		100	T	0.05	4
Platinum		1000–1500	T	0.14–0.18	1
Platinum		1094	T	0.18	4
Platinum		17	T	0.016	4
Platinum		22	T	0.03	4
Platinum		260	T	0.06	4
Platinum		538	T	0.10	4
Platinum	pure, polished	200–600	T	0.05–0.10	1
Platinum	ribbon	900–1100	T	0.12–0.17	1
Platinum	wire	1400	T	0.18	1
Platinum	wire	500–1000	T	0.10–0.16	1
Platinum	wire	50–200	T	0.06–0.07	1
Porcelain	glazed	20	T	0.92	1
Porcelain	white, shiny		T	0.70–0.75	1
Rubber	hard	20	T	0.95	1
Rubber	soft, gray, rough	20	T	0.95	1
Sand			T	0.60	1
Sand		20	T	0.90	2
Sandstone	polished	19	LLW	0.909	8
Sandstone	rough	19	LLW	0.935	8
Silver	polished	100	T	0.03	2
Silver	pure, polished	200–600	T	0.02–0.03	1
Skin	human	32	T	0.98	2
Slag	boiler	0–100	T	0.97–0.93	1
Slag	boiler	1400–1800	T	0.69–0.67	1
Slag	boiler	200–500	T	0.89–0.78	1

Table 31.1 T: Total spectrum; SW: 2–5 µm; LW: 8–14 µm, LLW: 6.5–20 µm; 1: Material; 2: Specification; 3: Temperature in °C; 4: Spectrum; 5: Emissivity; 6: Reference (continued)

1	2	3	4	5	6
Slag	boiler	600–1200	T	0.76–0.70	1
Snow: See Water					
Soil	dry	20	T	0.92	2
Soil	saturated with water	20	T	0.95	2
Stainless steel	alloy, 8% Ni, 18% Cr	500	T	0.35	1
Stainless steel	rolled	700	T	0.45	1
Stainless steel	sandblasted	700	T	0.70	1
Stainless steel	sheet, polished	70	SW	0.18	9
Stainless steel	sheet, polished	70	LW	0.14	9
Stainless steel	sheet, untreated, somewhat scratched	70	SW	0.30	9
Stainless steel	sheet, untreated, somewhat scratched	70	LW	0.28	9
Stainless steel	type 18-8, buffed	20	T	0.16	2
Stainless steel	type 18-8, oxidized at 800°C	60	T	0.85	2
Stucco	rough, lime	10–90	T	0.91	1
Styrofoam	insulation	37	SW	0.60	7
Tar			T	0.79–0.84	1
Tar	paper	20	T	0.91–0.93	1
Tile	glazed	17	SW	0.94	5
Tin	burnished	20–50	T	0.04–0.06	1
Tin	tin-plated sheet iron	100	T	0.07	2
Titanium	oxidized at 540°C	1000	T	0.60	1
Titanium	oxidized at 540°C	200	T	0.40	1
Titanium	oxidized at 540°C	500	T	0.50	1
Titanium	polished	1000	T	0.36	1
Titanium	polished	200	T	0.15	1
Titanium	polished	500	T	0.20	1
Tungsten		1500–2200	T	0.24–0.31	1
Tungsten		200	T	0.05	1
Tungsten		600–1000	T	0.1–0.16	1
Tungsten	filament	3300	T	0.39	1
Varnish	flat	20	SW	0.93	6
Varnish	on oak parquet floor	70	SW	0.90	9
Varnish	on oak parquet floor	70	LW	0.90–0.93	9
Wallpaper	slight pattern, light gray	20	SW	0.85	6
Wallpaper	slight pattern, red	20	SW	0.90	6
Water	distilled	20	T	0.96	2

Table 31.1 T: Total spectrum; SW: 2–5 μm ; LW: 8–14 μm , LLW: 6.5–20 μm ; 1: Material; 2: Specification; 3: Temperature in $^{\circ}\text{C}$; 4: Spectrum; 5: Emissivity; 6: Reference (continued)

1	2	3	4	5	6
Water	frost crystals	-10	T	0.98	2
Water	ice, covered with heavy frost	0	T	0.98	1
Water	ice, smooth	0	T	0.97	1
Water	ice, smooth	-10	T	0.96	2
Water	layer >0.1 mm thick	0–100	T	0.95–0.98	1
Water	snow		T	0.8	1
Water	snow	-10	T	0.85	2
Wood		17	SW	0.98	5
Wood		19	LLW	0.962	8
Wood	ground		T	0.5–0.7	1
Wood	pine, 4 different samples	70	SW	0.67–0.75	9
Wood	pine, 4 different samples	70	LW	0.81–0.89	9
Wood	planed	20	T	0.8–0.9	1
Wood	planed oak	20	T	0.90	2
Wood	planed oak	70	SW	0.77	9
Wood	planed oak	70	LW	0.88	9
Wood	plywood, smooth, dry	36	SW	0.82	7
Wood	plywood, untreated	20	SW	0.83	6
Wood	white, damp	20	T	0.7–0.8	1
Zinc	oxidized at 400 $^{\circ}\text{C}$	400	T	0.11	1
Zinc	oxidized surface	1000–1200	T	0.50–0.60	1
Zinc	polished	200–300	T	0.04–0.05	1
Zinc	sheet	50	T	0.20	1

A note on the technical production of this publication

This publication was produced using XML — the eXtensible Markup Language. For more information about XML, please visit <http://www.w3.org/XML/>

A note on the typeface used in this publication

This publication was typeset using Linotype Helvetica™ World. Helvetica™ was designed by Max Miedinger (1910–1980)

LOEF (List Of Effective Files)

T501007.xml; en-US; AS; 40301; 2017-02-14
T505473.xml; en-US; 15553; 2014-06-30
T505474.xml; en-US; 39512; 2017-01-18
T505013.xml; en-US; 39689; 2017-01-25
T505209.xml; en-US; 40299; 2017-02-14
T505201.xml; en-US; 40299; 2017-02-14
T506044.xml; en-US; 39512; 2017-01-18
T505500.xml; en-US; 39512; 2017-01-18
T505015.xml; en-US; 39512; 2017-01-18
T505200.xml; en-US; 39512; 2017-01-18
T505199.xml; en-US; 39540; 2017-01-19
T505669.xml; en-US; 39512; 2017-01-18
T505480.xml; en-US; 39515; 2017-01-18
T505204.xml; en-US; 39512; 2017-01-18
T505205.xml; en-US; 39540; 2017-01-19
T505259.xml; en-US; 39682; 2017-01-25
T505501.xml; en-US; 32514; 2016-01-19
T505260.xml; en-US; 40299; 2017-02-14
T506090.xml; en-US; 40276; 2017-02-14
T506094.xml; en-US; 40294; 2017-02-14
T506091.xml; en-US; 40299; 2017-02-14
T505206.xml; en-US; 39512; 2017-01-18
T505208.xml; en-US; 40250; 2017-02-13
T505202.xml; en-US; 39512; 2017-01-18
T505007.xml; en-US; 39512; 2017-01-18
T505004.xml; en-US; 39512; 2017-01-18
T505000.xml; en-US; 39687; 2017-01-25
T505005.xml; en-US; 39512; 2017-01-18
T505001.xml; en-US; 39512; 2017-01-18
T505006.xml; en-US; 39581; 2017-01-20
T505002.xml; en-US; 39512; 2017-01-18



Website

<http://www.flir.com>

Customer support

<http://support.flir.com>

Copyright

© 2017, FLIR Systems, Inc. All rights reserved worldwide.

Disclaimer

Specifications subject to change without further notice. Models and accessories subject to regional market considerations. License procedures may apply. Products described herein may be subject to US Export Regulations. Please refer to exportquestions@flir.com with any questions.

Publ. No.: T810209
Release: AS
Commit: 40301
Head: 40301
Language: en-US
Modified: 2017-02-14
Formatted: 2017-02-14