

The logo for CHINO, consisting of the word "CHINO" in a bold, white, sans-serif font, centered within a dark gray rectangular background.

Integrated Application Software

**TRAMS IV**

---

## **INSTRUCTIONS**

A small, solid gray square located at the bottom right of the page, below the "INSTRUCTIONS" header.

Thank you for purchasing Integrated Application Software "TRAMS IV".  
For using this application correctly and safety, please read this instruction manual  
thoroughly before installing. IV  
In the following pages, [TRAMS] is abbreviated as [TRAMS].

**CHINO**

## Introduction

This instruction manual describes hardware preparation, program installation, operation method, etc. To fully understand this software and prevent troubles, be sure to read this instruction manual before installing.

### Cautions

1. Scope  
The following license terms apply to the CHINO product you purchased this time.
2. Copyright  
This software is protected by copyright law and international copyright, other intangible property rights law and treaty. All intellectual property rights such as patents, copyrights, commercial confidentiality, trademark rights, etc. relating to this software is owned by Chino Corporation (hereinafter referred to as CHINO).
3. Scope of license  
The software may be used only for the instrument you purchased.  
Within the scope of use, the software may be installed on more than one PC by more than one user.
4. Prohibition of use by the third party  
It is not possible for third parties to use this software by re-use permission, assignment, distribution, loan or other method.
5. Restriction on copying  
You may only make a copy of this software which is provided in the form of a storage medium for backup usage.
6. Prohibition of modifications  
You may not alter or modify this software (including partial integration of this software to other software).
7. Guarantee  
Because this software is provided free of charge, CHINO will not support and operation compensation by our company. In addition, we will not be obligated to solve any problems with software.
8. Limitation of liability  
CHINO is not responsible in any case for any direct or indirect losses and damages incidental or related by the operation of this software. In addition, we are not responsible for any dispute arising between you and a third party.
9. Operation at power failure  
When it is impossible to supply power such as power failure, the software will stop. Also, please make sure beforehand that you will need to start up manually even when power is restored.
10. Others  
Chino may change the specifications of this product for future improvement and other reasons without any notice. Moreover, there may be a difference between the screen image at the time of creating this manual and the actual screen.

## Warnings

1. No part of this manual can be reproduced or transferred in any form without permission.
2. Description contents of this manual may be changed without notice.
3. We take carefully thought-out about the contents of this manual.  
However, if you should have found a doubtful point, an error, a skipped description, please contact your nearest Chino's sales office.
4. CHINO is not responsible for any operation results of this software.

## Trademarks

1. Microsoft, Windows, .NET Framework, Office and Excel are the trademarks of US Microsoft Corporation and the related companies.
2. Other described company names and product name are trademarks and registered products of the respective companies.
3. Please note that the marks TM and ® marks are omitted throughout this manual.

## Precautions

1. Keep this instruction manual carefully until this software is discarded.
2. When discarding this software, according to the dust collection methods specified by each local self-governing community and cooperate for recycle, etc.

# Table of Contents

Introduction .....	1	12-2 Parameter setting window (specify file / specify model code) .....	74
Table of Contents.....	3	<b>12-2-1</b> Loading and writing device parameter file.....	75
<b>1 Overview.....</b>	<b>5</b>	12-3 Print Device Format / Output Device Format	85
1-1 About TRAMS .....	5	<b>12-3-1</b> Overview.....	85
1-2 Compatible Models .....	6	<b>12-3-2</b> Print device format.....	85
1-3 System configuration example .....	8	<b>12-3-3</b> Output device format.....	85
1-4 Communication cable .....	10	12-4 Barcode recipe output.....	86
1-5 Communication line connection .....	12	<b>12-4-1</b> Overview.....	86
1-6 SB700 Communication Module configuration	15	<b>12-4-2</b> Barcode recipe file.....	86
1-7 Line converter setting .....	18	<b>12-4-3</b> Creating procedure .....	88
1-8 Engineering port .....	19	12-5 DP-G parameter setting.....	93
1-9 TRAMS operating condition .....	22	<b>12-5-1</b> Cautions when reading patterns in communication.....	93
1-10 Software configuration .....	23	<b>12-5-2</b> Cautions on DP-G parameter setting.....	94
<b>2 How to setup .....</b>	<b>26</b>	<b>12-5-3</b> Parameter file saving.....	94
2-1 Installation .....	26	<b>12-5-4</b> How to open parameter file.....	96
<b>2-1-1</b> New installation.....	26	<b>12-5-5</b> Writing parameter through communication...97	
<b>2-1-2</b> Installation at the version upgrade .....	29	12-6 Kps Viewer .....	98
<b>2-1-3</b> Power supply control .....	29	<b>13 Data acquisition .....</b>	<b>100</b>
2-2 Uninstallation .....	30	13-1 Data acquisition operation .....	100
2-3 TRAMS folder structure .....	32	13-2 Data registration window .....	103
<b>3 Startup and Exit of TRAMS .....</b>	<b>33</b>	<b>13-2-1</b> Data edit window.....	105
3-1 Startup .....	33	13-3 Group registration window.....	107
3-2 Exit.....	34	<b>13-3-1</b> Group edit window .....	108
<b>4 How to Operate .....</b>	<b>35</b>	13-4 Acquisition group management window...109	
4-1 Flow of operation .....	35	13-5 Alarm display window .....	110
4-2 Operation of home .....	37	13-6 Data memory operation window .....	111
4-3 How to open a file.....	37	13-7 Trend graph display window.....	115
<b>5 Initial settings and functions .....</b>	<b>38</b>	<b>13-7-1</b> Data setting window.....	118
5-1 Initial settings.....	38	<b>13-7-2</b> Graph area setting window.....	119
5-2 TRAMS Functions .....	39	<b>13-7-3</b> Scale plate setting window.....	120
<b>6 Port registration .....</b>	<b>40</b>	<b>13-7-4</b> Numeric data setting window.....	123
6-1 Port edit window .....	41	<b>13-7-5</b> Operation setting window.....	124
<b>7 Device registration.....</b>	<b>42</b>	13-8 Real-time data list display window .....	126
7-1 Model code input window .....	43	<b>13-8-1</b> Display setting window.....	127
7-2 Device registration wizard window .....	44	<b>14 Data analysis .....</b>	<b>128</b>
7-3 Device scan window .....	46	14-1 Data analysis window .....	129
7-4 Device setting edit window .....	51	14-2 Toolbar .....	130
<b>8 Summary display .....</b>	<b>54</b>	14-3 Operation of home .....	132
8-1 Summary search window .....	55	<b>14-3-1</b> Data list display window.....	133
8-2 Summary setting window.....	57	<b>14-3-2</b> Daily report output window.....	137
<b>9 Registered device condition display ..</b>	<b>58</b>	<b>14-3-3</b> Monthly report output window.....	142
<b>10 Device data file auto collection .....</b>	<b>59</b>	<b>14-3-4</b> Specific period printing .....	147
10-1 Device data file auto collection setting..	61	<b>14-3-5</b> [Connect to previous file], [Connect all files], [Connect to following file] functions.....	148
10-2 Device data file auto collection error .....	63	<b>14-3-6</b> List of connecting files window.....	149
<b>10-2-1</b> [Unable to connect to the remote server].....	63	<b>14-3-7</b> [Batch information display] window .....	151
<b>10-2-2</b> [Unable to access FTP directory.] .....	64	14-4 Operation of display .....	152
<b>11 Version information display .....</b>	<b>65</b>	14-5 Operation of setting .....	154
<b>12 Parameter setting .....</b>	<b>66</b>	<b>14-5-1</b> Analysis file setting window.....	155
12-1 Parameter setting window (specify registered device).....	67	<b>14-5-2</b> Data setting window .....	156
<b>12-1-1</b> Device parameter loading and writing .....	70	<b>14-5-3</b> Graph area setting window .....	159
<b>12-1-2</b> Device parameter file saving.....	72	<b>14-5-4</b> Scale plate setting window.....	161
		<b>14-5-5</b> Numeric data/ bar graph setting window.....	163
		14-6 Numeric data/ Bar graph display area .....	165
		14-7 Trend graph display area .....	167
		<b>14-7-1</b> Operation of scale plate area.....	170
		<b>14-7-2</b> Operation of message .....	171
		<b>14-7-3</b> Operation of marker text .....	173
		14-8 Signature operation .....	174
		<b>14-8-1</b> File property .....	175
		<b>14-8-2</b> Other setting functions.....	177



---

<b>15</b>	<b>Operation of Favorite.....</b>	<b>178</b>
<b>16</b>	<b>Troubleshooting .....</b>	<b>182</b>

---

# 1 Overview

## 1-1 About TRAMS

Thank you for using integrated application software TRAMS.  
TRAMS can be connected to our recorders, controller and setting units (for compatible equipment: see 1-2) and following operations can be performed.

- ◆ Parameter settings  
Various parameters can be set from TRAMS easily. In addition, you can save and change setting data.
  
- ◆ Data recording  
You can record measured values (PV) of the recorder, measured values (PV) of the controller, set value (SV), output value (MV), etc.
  
- ◆ Data analysis  
Recorded measurement values (PV) can be reproduced and analyzed on TRAMS.

Communication supports serial port 1 and Ethernet, total 32 devices can be connected. Up to 300 points can be displayed and data can be recorded on the measured data of the connected device on the personal computer. (However, up to 31 devices can be connected to the line converter or SB700 Communication module via RS485.)

Also, DB1000/ DB2000 digital Indicating controller, KP1000/ KP2000 digital program controller, KP3000 digital program setting unit, DB600 digital Indicating controller, DP1000G/ DP2000G/ DP3000G Graphic Program Controller/Setter and DI5000 digital indicator with alarms have an engineering port. It is possible to perform parameter setting by USB connection with a personal computer with an engineering cable that is sold separately. (In this case, you can not always communicate data such as data acquisition.)

## 1-2 Compatible Models

The corresponding models are as follows. Unwritten models are not supported.

For details, refer to the instruction manual for each instrument.

In addition, please be aware that special specifications etc. may not be supported even if it is described below.

Device	Model	Serial Communication	Ethernet	USB	Parameter settings ( Files that can be opened )	Data recording	Data analysis ( Files that can be opened )
Controller	DB630	M	$\Delta^{*10}$	$\Delta^{*1}$	Serial communication or USB (pasconf)	Setting value	○ (dmf/ zil)
	DB650 DB670			$\Delta^{*2}$			
	DB1000	M	$\Delta^{*10}$	$\Delta^{*1}$	Serial communication or USB (pasconf/ pkp)	Indicated value	
	DB2000	M	$\Delta^{*10}$	$\Delta^{*1}$	Serial communication or USB (pasconf/ pkp)	Output value	
	KP1000	M	$\Delta^{*10}$	$\Delta^{*1}$			
	KP2000 (KP2500)	M	$\Delta^{*10}$	$\Delta^{*1}$			
	KP3000	M	$\Delta^{*10}$	$\Delta^{*1}$	x	SP value	
	LT23A	M	$\Delta^{*10}$	x <sup>*7</sup>		PV value	
	LT35A/ 37A	M	$\Delta^{*10}$	x <sup>*7</sup>		MV value	
	LT45A/ 47A	M	$\Delta^{*10}$	x <sup>*7</sup>			
	DP1000G	M	$\Delta^{*10}$	$\Delta^{*1}$	Serial communication or USB (pasconf/ ds/ dp)	Setting value	
	DP2000G					Indicated value	
	DP3000G					Output value Input switch status* (*Only DP2000G)	
SB100	Please use the SB setting software. (TRAMS is not supported.)						
Indicator	DI5000	M	$\Delta^{*10}$	$\Delta^{*2}$	Serial communication or USB (pasconf)	Measured value Maximum Value Minimum value	○ (dmf/ zil)
Recorder	KR2000 KR3000	M	○	x <sup>*3</sup>	Serial communication or Ethernet (pasconf/ krs)	Measured value <sup>*4</sup>	○ <sup>*5</sup> (dmf/ zil/ krf)
	KR2S/ 3S KR2D/ 3D (KRH)	M	○	x <sup>*3</sup>	Serial communication or Ethernet (pasconf/ krs/ kps)	Measured value <sup>*4</sup>	○ <sup>*5</sup> (dmf/ zil/ krf /kpf)
	SC5000	M	○	x	x	Measured value <sup>*4</sup>	○ <sup>*5</sup> (dmf/ zil/ krf)
	AL4000 AH4000	M	○	○ <sup>*9</sup>	Serial communication, Ethernet or USB (pasconf/ a4s)	Measured value	○ <sup>*6</sup> (dmf/ zil/ a4f)
	KL4000 KH4000	M	$\Delta^{*10}$	○ <sup>*9</sup>	Serial communication or USB (pasconf)	Measured value	○ (dmf/ zil)
	LE5100 LE5200	M	○	x <sup>*3</sup>	x	Measured value	○ <sup>*8</sup> (dmf/ zil/ l5f)

Converter	KT-M	M	$\Delta^{*10}$	x	○ Serial communication (pasconf)	Temperature Voltage	○ (dmf/ zil)
-----------	------	---	----------------	---	--	------------------------	-----------------

- \*1 USB can parameter setting only by engineering cable (RZ-EC4).
- \*2 USB can parameter setting only by engineering cable (RZ-EC4 or RZ-EC5).
- \*3 There is a USB port on the device, but it is not available in TRAMS.
- \*4 Device data file can be acquired automatically by FTP server function.
- \*5 The krf file can be read by the data analysis function.
- \*6 The a4f file can be read by the data analysis function.
- \*7 There is a loader connector on the device, but it is not available in TRAMS.
- \*8 The l5f file can be read by the data analysis function.
- \*9 Acquisition via USB is not available.
- \*10 Communication through Ethernet is available by using SB700 communication module.

File type - Parameter setting files	
*.pasconf	Parameter setting file saved by TRAMS
*.pkp	Parameter setting file created by PASS
*.krs	Parameter setting file created by KR
*.kps	Parameter setting file created by KR Heat Treatment Assistance Spec.
*.a4s	Parameter setting file created by KR AL4000/ AH4000
*.ds1, ds2, ds3	Parameter setting file created by DP1000G, DP2000G, DP3000G
*.dp1, dp2, dp3	Program pattern file created by DP1000G, DP2000G, DP3000G

File type - Data files	
*.dmf	Data file recorded by TRAMS
*.zil	Data analysis file saved by TRAMS
*.a4f	Data files recorded by AL4000/ AH4000
*.krf	Data files recorded by KR series and SC5000
*.l5f	Data files recorded by LE5100, LE5200
*.kpf	Data files recorded by KR Heat Treatment Assistance Spec.

#### Reference

- The M notation of serial communication is MODBUS protocol.
- Please confirm the communication interface to use when purchasing equipment.  
(The communication interface may be optional.)
- It does not correspond to each file created by our software KIDS and ZAILA.
- Setting file created by CHINO software PASS (pkp) corresponds to DB1000, DB2000, KP1000, KP2000 and KP3000 only.  
It does not to correspond to pkp files created by other models.

### 1-3 System configuration example

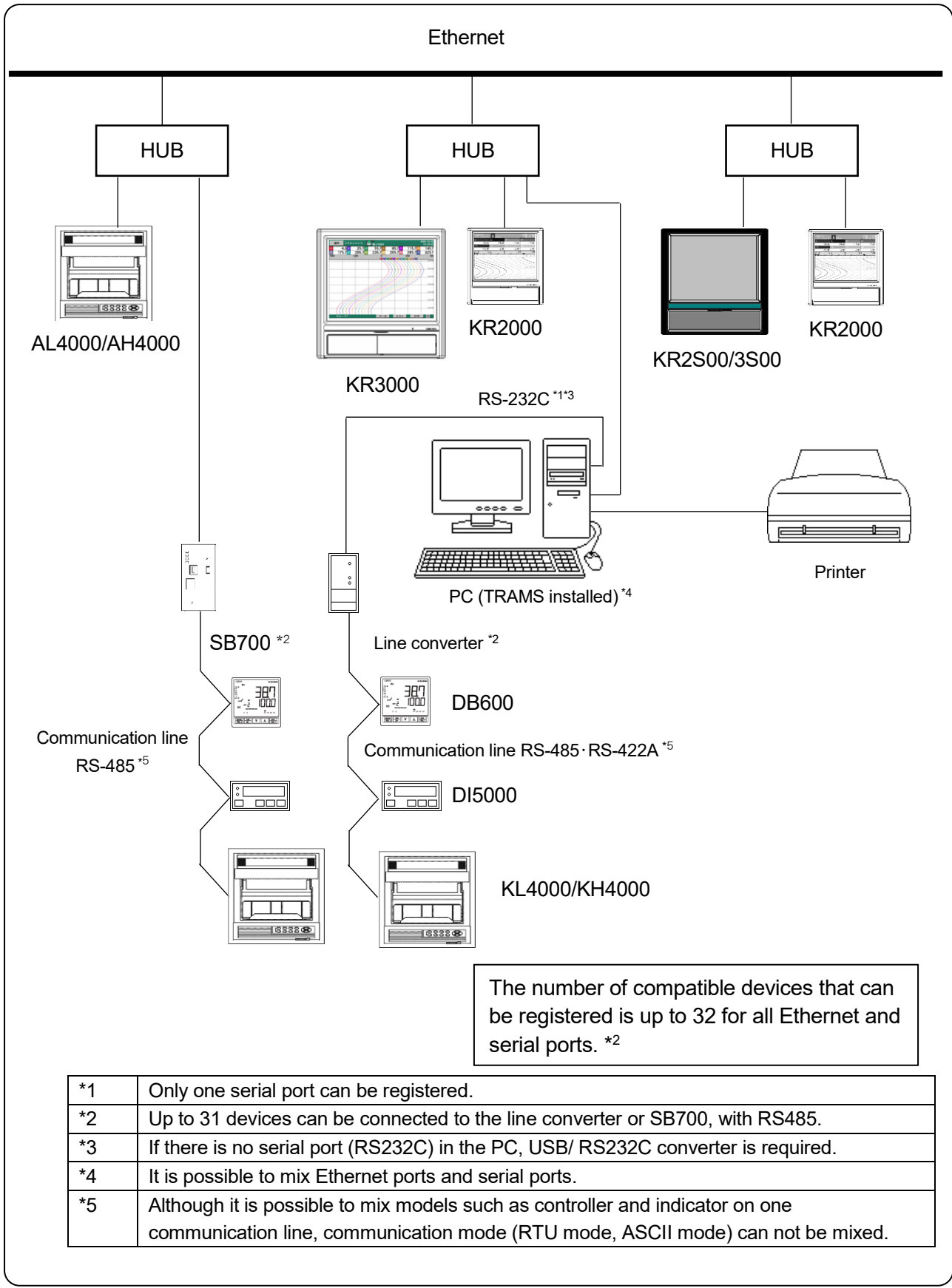

**Caution**

- To use RS-422A and RS-485 for communication interface, line convertor SC8-10 or SB700 communication module is required.
- To use SB700, change the time out setting value as follows.

(1) Set serial communication time out value of the SB700 smaller than the TRAMS's.

Or

(2) Set time out value of the TRAMS's bigger than the serial communication time out value of the SB700.

# 1-4 Communication cable

Prepare communication cables before starting the connection.  
If it is required, please contact CHINO.

## ◆ RS-232C

Connection between PC and units (recorder, controller, line converter)

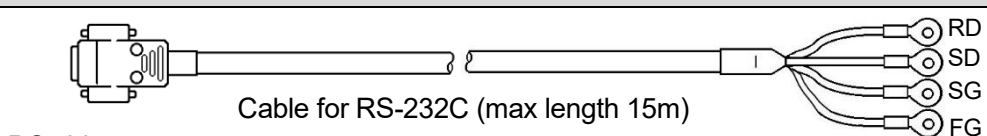
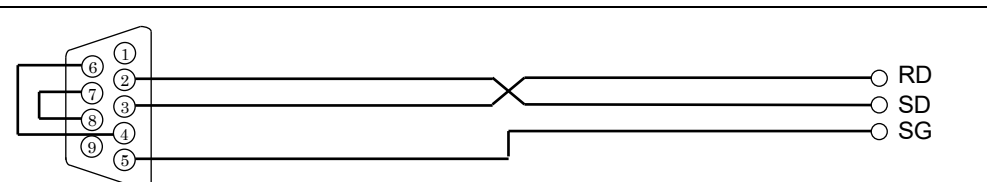
Cable	9-pin connector ←→ O type crimp style terminal RS-232C cable
Shape	 <p>Cable for RS-232C (max length 15m)</p> <p>PC side 9-pin connector</p> <p>If the device does not have FG, ground to a proper place. Cut it, if it is unnecessary.</p> <p>Unit side</p>
Internal wiring	
Model code	<p>RZ-CRS6 <input type="checkbox"/> <input type="checkbox"/></p> <p>Cable length 01 to 15m (specified)</p>

## ◆ RS-422A

● Connection between line converter and unit

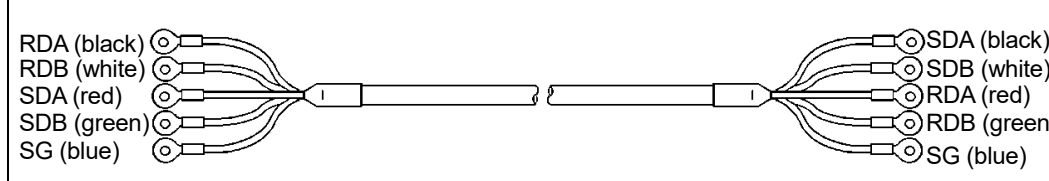
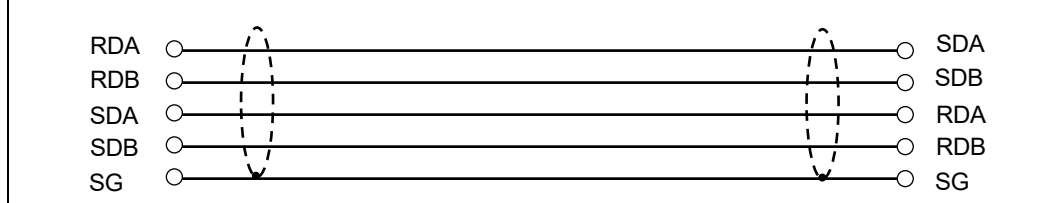
Cable	O type crimp style terminal ←→ O type crimp style terminal RS422A cable (for line converter)
Shape	 <p>Line converter side</p> <p>Unit side</p> <p>4-core cable of twisted 2-core cables of twisted VCTF lines. Each side has a SG (single ground) line. Since the line converter has no SG terminal, cut and use the cable.</p>
Internal wiring	
Model code	<p>RZ-CRA2 <input type="checkbox"/> <input type="checkbox"/></p> <p>Cable length 01 to 99m (specified)</p>

● Connection between units

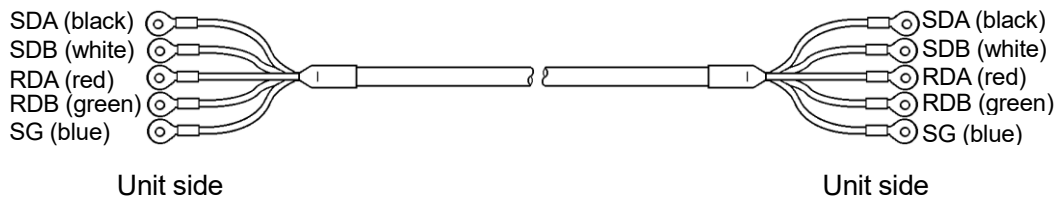
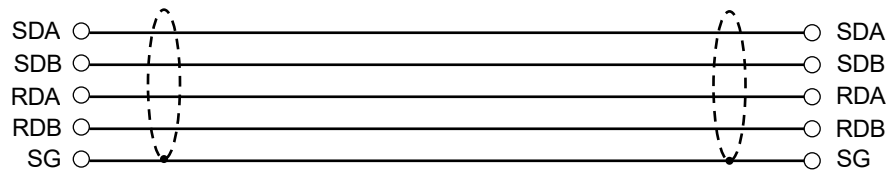
Cable	O type crimp style terminal ←→ O type crimp style terminal RS-422A cable (for parallel)
Profile	 <p>The cable is a 4-core cable which is made up by twisted 2-core twisted VCTF lines. SG (signal ground) wire is prepared on both sides.</p>
Internal connection	
Model code	RZ-CRA1□□ Cable length 01 to 99m (Designated)

◆ RS-485

Connection between units, and between line converter and unit.

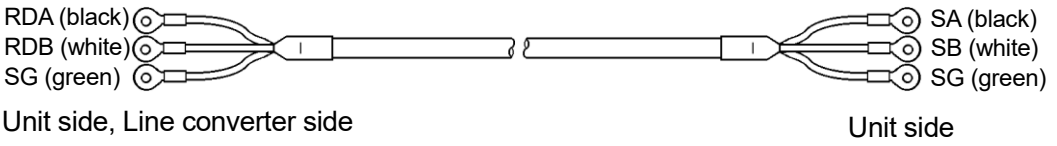
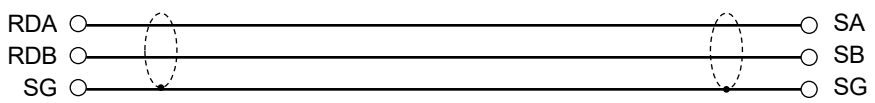
Cable	O type crimp style terminal ←→ O type crimp style terminal RS-485 cable
Profile	 <p>The cable is CVVS lines twisted 2-core cable. SG (signal ground) wire is prepared on both sides. Since the SG terminal is not provided on the line converter side, cut the cable before use.</p>
Internal connection	
Model code	RZ-LEC□□□ Cable length 01 to 200m (Designated)

◆ Ethernet

● Connection between PC and a unit

When connecting PC and unit directly (one-to-one), use a shielded, crossover twisted pair cable (commercially available STP cable).

● Connection between HUB and units (Plural units are connectable)

When connecting PC and units via HUB (one-to-N), use a shielded, straight pair cable (commercially available STP cable).



## 1-5 Communication line connection

TRAMS is applicable to various serial communication interfaces (RS232C, RS422A, RS485) and Ethernet. The connection method differs by every communication interface. Refer to each unit instruction manual for the setting method.

### ◆ RS-422A connection example

In RS422A, the PC and plural units are connected to each other. Line converter is necessary.

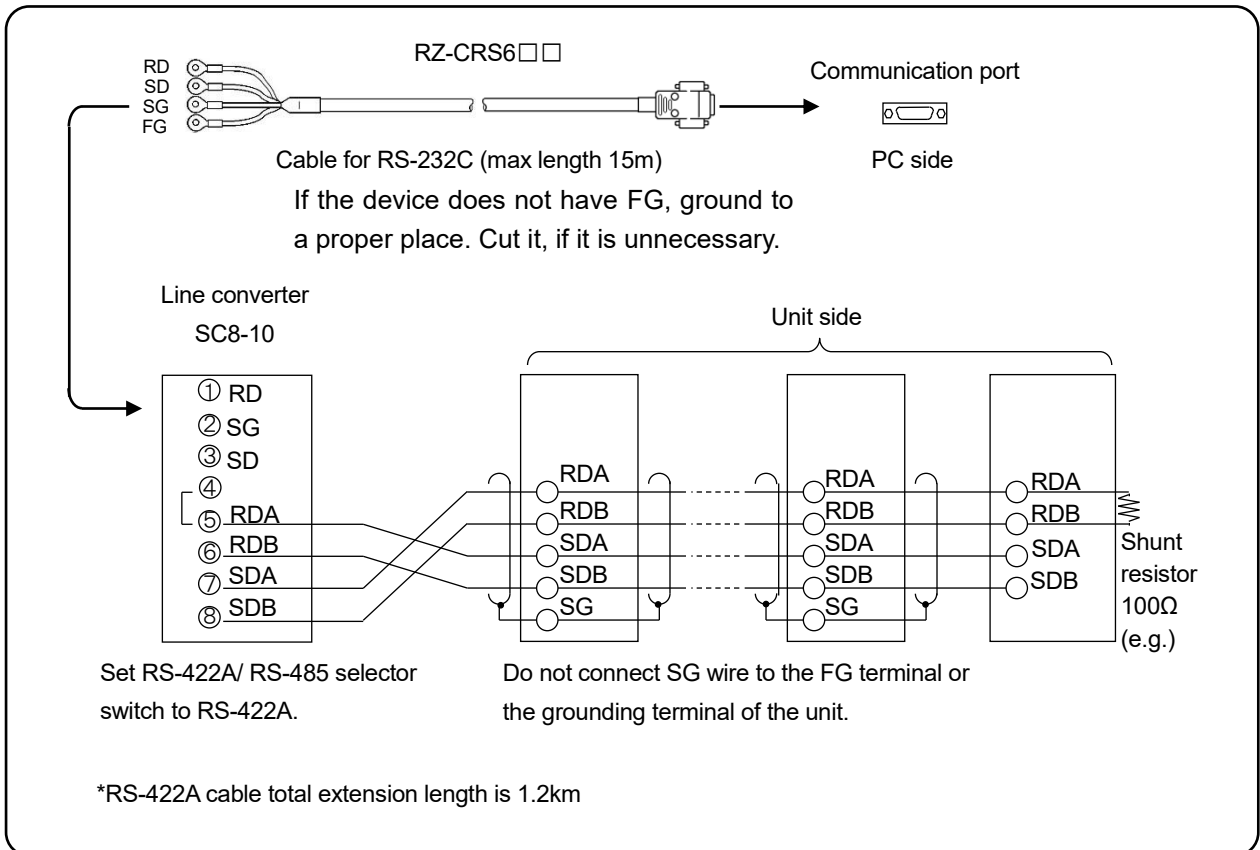

**Caution**

The optimum value of the shunt resistor value varies depending on the unit. For details, please refer to the instruction manual of each unit.

◆ RS-485 connection example

In RS485, the PC and plural units are connected to each other. Line converter is required.

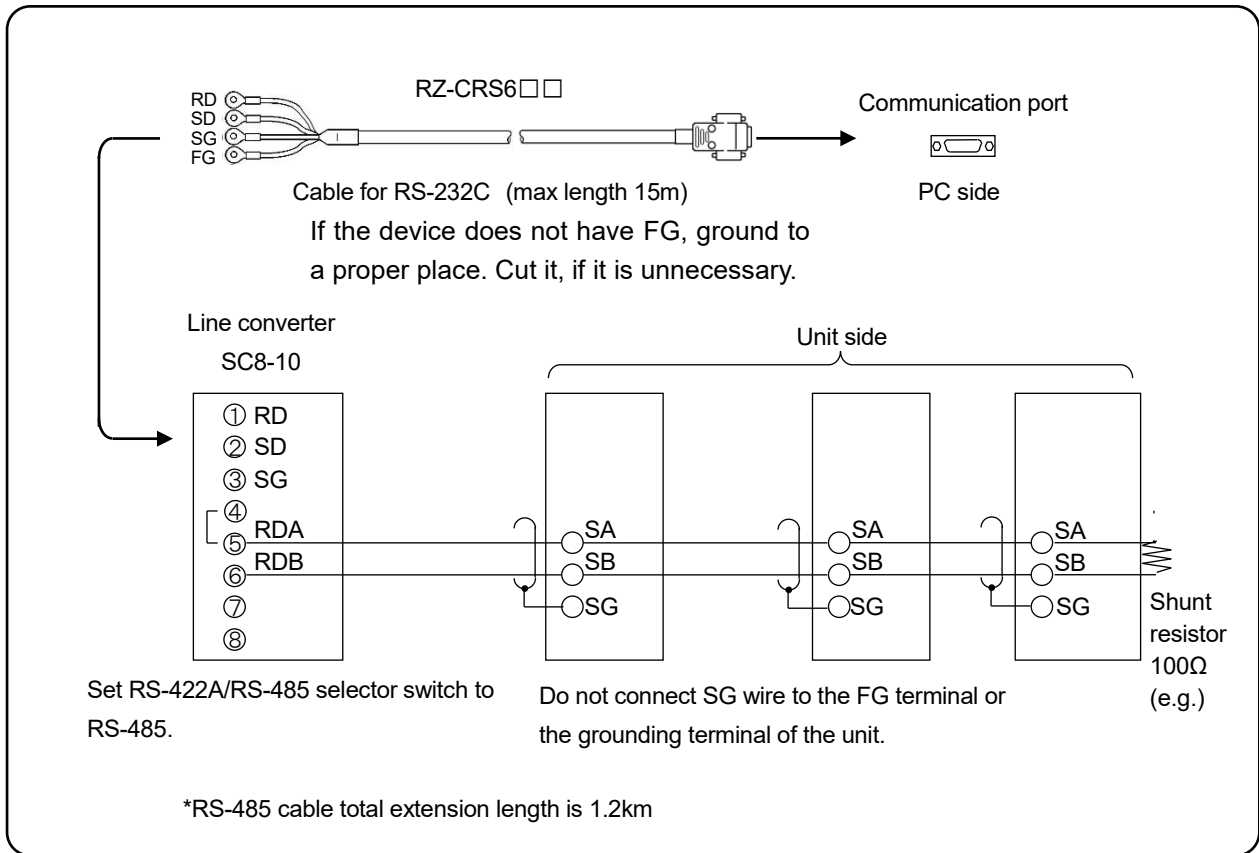

**Caution**

The optimum value of the shunt resistor value varies depending on the unit. For details, please refer to the instruction manual of each unit.

◆ Ethernet connection example

- Connection example between PC and Ethernet unit (one-to-one connection)

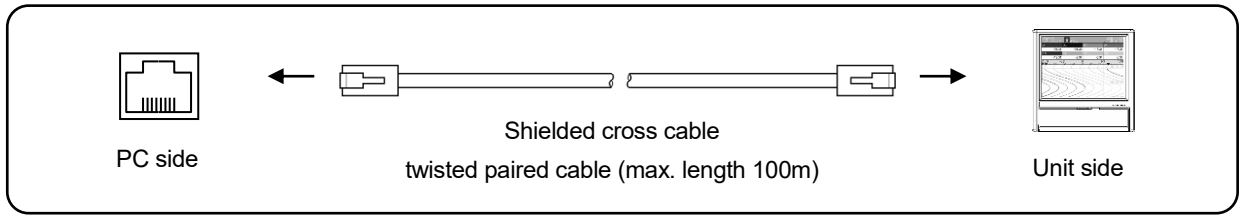

- Connection example between PC and HUB/Ethernet unit side (one-to-N connection)

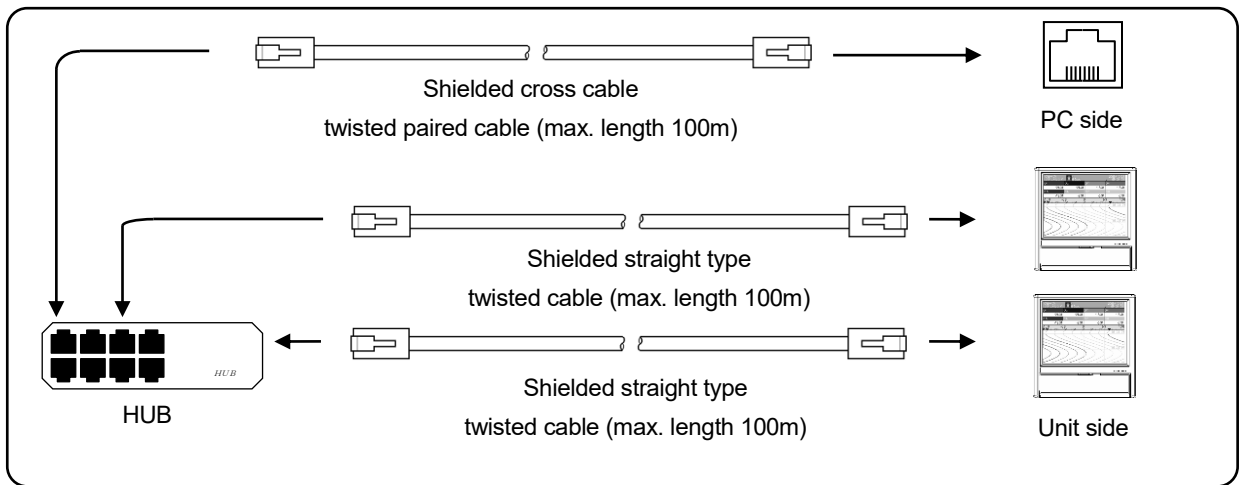

## 1-6 SB700 Communication Module configuration

To use SB700 communication module, setting required to connect to the TRAMS is set from SB setting software, not in the TRAMS. For details, refer to SB700 communication Module Instruction Manual [Setting].

### <Procedure>

- (1) Start the SB setting software. Click “Communication setup” → “Communication settings (PC)”.

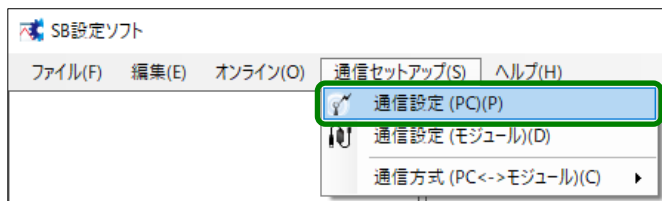

- (2) The setting using engineering communication is described below.

Configure the COM port number for the COM port to which the USB engineering cable is connected.

\* Check the COM port using the Device Manager.

Click the [OK] button.

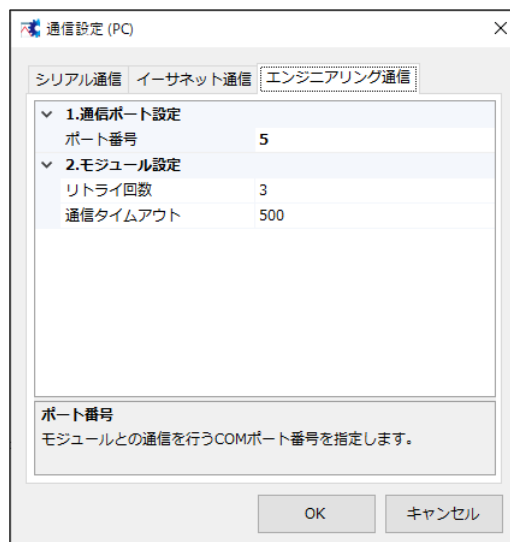

- (3) Click “Communication setup” → “Communication settings (module)”.

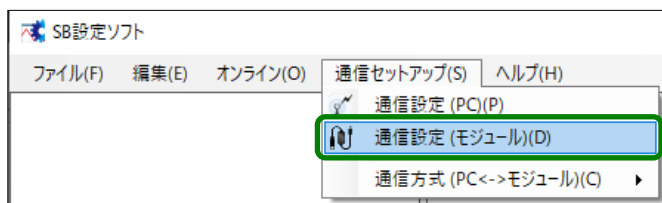

- (4) The USB engineering cable connection window will be displayed.

Click the [OK] button. The window will close.

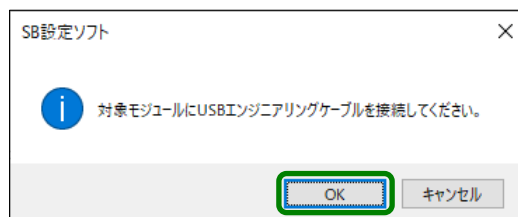

## (5) Configure Ethernet communication.

## - IP address

Configure the IP address. Ask the network administrator for the IP address.

## - Subnet mask

Configure the subnet mask.

## - Default gateway

If there are any gateways such as routers on the network, set the default gateway address.

## - Port number

Set the port number to use for TCP/IP socket communication. TRAMS does not support Modbus TCP (port number 502).

## - NAK response

Configure whether or not to use NAK response when in serial reception standby and being unable to perform subsequent Ethernet/serial conversion. Let it be turned OFF, when communicating through TRAMS.

## - TCP connection timeout

Set the amount of time (in seconds) before disconnecting when failing to receive Ethernet communication following the establishment of a TCP connection.

通信設定 (モジュール)

読み込み 書き込み

0. モジュール情報

形式コード SB700-00-0  
シリアル番号 B7-S198A0005  
ROMバージョン  
MACアドレス

1. 通信設定 (イーサネット)

IPアドレス 192.168.254.254  
サブネットマスク 255.255.255.0  
デフォルトゲートウェイ 0.0.0.0  
ポート番号1 502  
ポート番号2 11111  
NAK応答 OFF  
TCP接続タイムアウト時間 0

2. 通信設定 (シリアル通信)

通信プロトコル 0: Modbus RTU  
ビットレート 4: 115200bps  
通信キャラクタ 0: 8bit/無し/ストップ\*1  
シリアル通信タイムアウト時間 5000

3. システム設定

故障予知アラーム表示 OFF

IPアドレス  
モジュールのIPアドレスを指定して下さい。

## (6) Configure serial communication settings.

Configure the transmission protocol, bitrate, and transmission format.

It is necessary to match the communication settings of the devices connecting to the SB700 to these settings. If the configuration differs between modules, communication will not be possible.

Item	Setting range	
Communications protocol	0	Modbus RTU (default value)
	1	Modbus ASCII
Bitrate	0	9600 bps (default value)
	1	19200 bps
	2	38400 bps
	3	57600 bps
	4	115200 bps

If the communication protocol is Modbus RTU, the communication format can only be 8 bit. When the communication protocol is changed, the communication format will switch to its default value.

Item	Setting range	
Communications format	0	8 bit/no parity/stop bit 1 (default value)
	1	8 bit/no parity/stop bit 2
	2	8 bit/even parity/stop bit 1
	3	8 bit/even parity/stop bit 2
	4	8 bit/odd parity/stop bit 1
	5	8 bit/odd parity/stop bit 2
	6	7 bit/even parity/stop bit 1*
	7	7 bit/even parity/stop bit 2
	8	7 bit/odd parity/stop bit 1
9	7 bit/odd parity/stop bit 2	

\* Modbus ASCII default value: 7 bit/even parity/stop bit 1

通信設定 (モジュール)

読み込み 書き込み

0. モジュール情報

形式コード SB700-00-0  
シリアル番号 B7-S198A0005  
ROMバージョン  
MACアドレス

1. 通信設定 (イーサネット)

IPアドレス 192.168.254.254  
サブネットマスク 255.255.255.0  
デフォルトゲートウェイ 0.0.0.0  
ポート番号1 502  
ポート番号2 11111  
NAK応答 OFF  
TCP接続タイムアウト時間 0

2. 通信設定 (シリアル通信)

通信プロトコル 0: Modbus RTU  
ビットレート 4: 115200bps  
通信キャラクタ 0: 8bit/無し/ストップ\*1  
シリアル通信タイムアウト時間 5000

3. システム設定

故障予知アラーム表示 OFF

通信プロトコル  
以下の通信プロトコルから指定します。  
0: Modbus RTUモード 1: Modbus ASCIIモード

- (7) For serial communication time-out time\*, set response wait time (millisecond) of the device connected to SB700.
- (8) Click the [Write] button. The communication settings will be written to the module.



## Caution

**\*To use SB700, change the time out setting value as follows.**

- (1) Set serial communication time out value of the SB700 smaller than the TRAMS's.**  
**Or**
- (2) Set time out value of the TRAMS's bigger than the serial communication time out value of the SB700.**

# 1-7 Line converter setting

Set the communication speed (bit rate) necessary for connecting to TRAMS and communication types (RS422A, RS485). For details, refer to the instruction manual for line converter.

By opening the lower cover at the front of the line converter, the communication speed (bit rate) selector switch and the communication type (RS422A, RS485) selector switch are mounted.

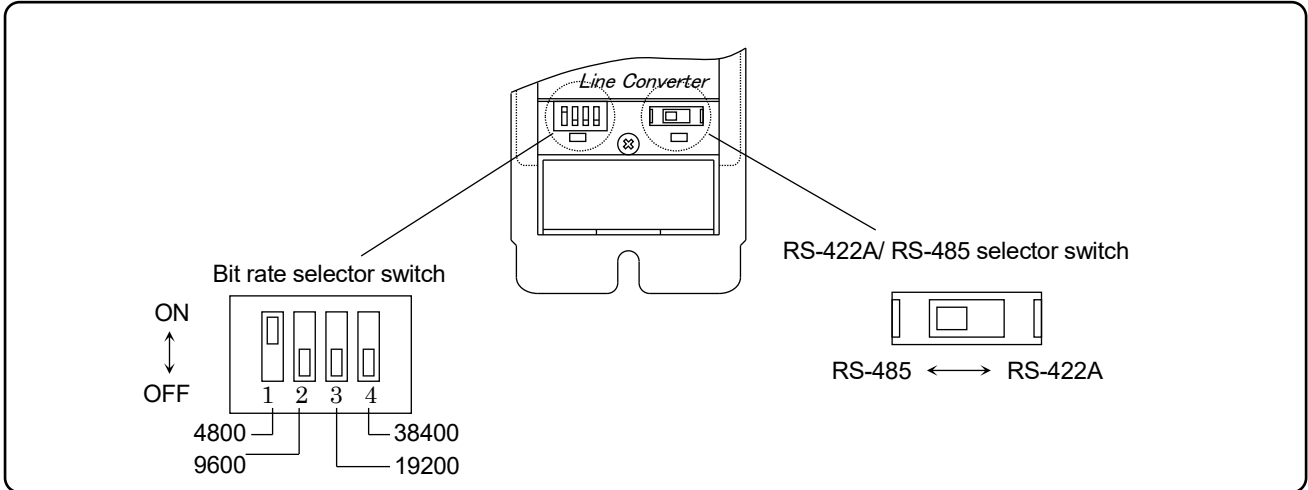

**Caution** Select two switches before mounting the line converter. (The lower cover does not open after mounting the unit.)

## 1. Communication speed (bit rate setting)

In case of RS485, turn on the selector switch of the communication speed employed.

\*For RS-422A, no setting is necessary.

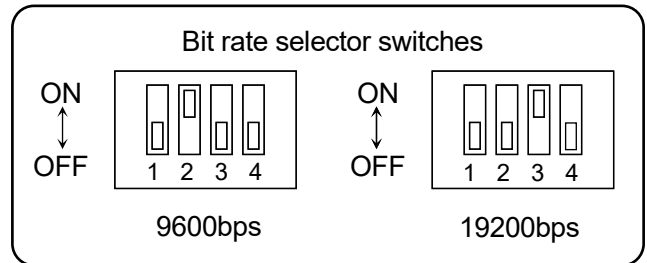

## 2. Communication type setting

Select the communication type according to the communication interface of the unit to be connected.

(The communication type is preset to RS422A (right side) at the delivery time from our factory.)

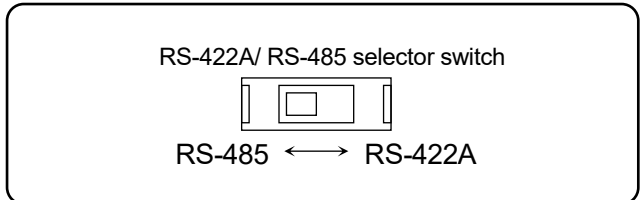

# 1-8 Engineering port

For the unit with engineering cable, setting of various parameters are made easy by using a cable.

	DB1000 DB2000	KP1000 KP2000 KP3000	DP1000G DP2000G DP3000G	DB630	DB650/ 670	DI5000
Engineering port location	Unit case front			Unit case bottom	Unit case top (for RZ-EC4), Front (for RZ-EC5)	Unit case right side (for RZ-EC4), front (for RZ-EC5)
Cable	RZ-EC4 USB engineering cable (optional)			RZ-EC4 USB engineering cable (optional) or RZ-EC5 IR engineering cable (optional)	RZ-EC4 USB engineering cable (optional) RZ-EC5 IR engineering cable (optional) *It can not be used when equipment is installed in close installation.	
Supported OS	Windows 10 (32bit/ 64bit), Windows11(64bit)					
Port of PC	USB					
Communication protocol	MODBUS-RTU	MODBUS-RTU/ ASCII	MODBUS-RTU			
Communication transmission speed	9600bps	19200bps	9600bps			
Communication character	Bit length 8/ Parity NON/ Stop bit 1					

	AL4000 / AH4000
Port location	Unit front
Cable	Mini-USB cable (use commercial product)

**Reference**

To communicate through USB on AL4000/ AH4000/ KL4000/ KH4000, USB driver is required. Download the driver from CHINO's homepage and install it. As of June 2023, this USB driver does not support Windows 11.

DB1000/ 2000 Digital Indicating Controller, KP1000/ KP2000 Digital Program Controller, KP3000 Digital Program Setter

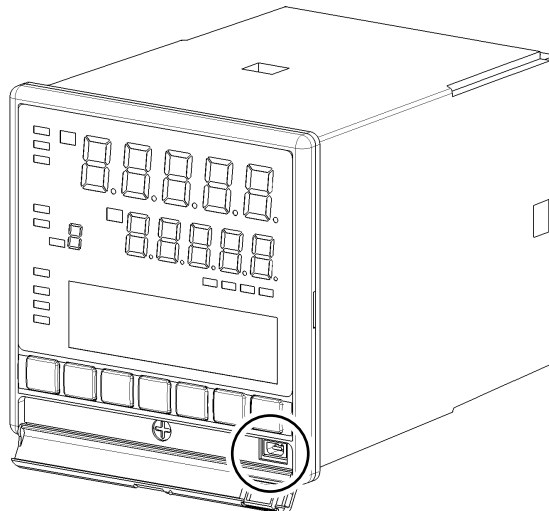



DB600 Digital Indicating Controller

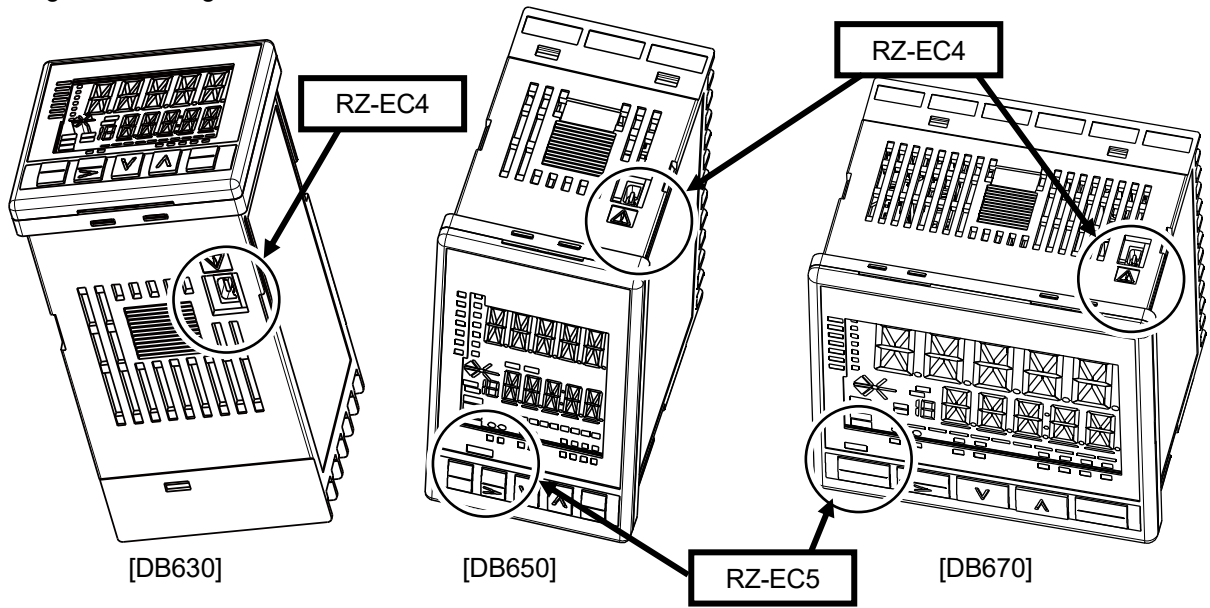

D15000 Digital Indicator

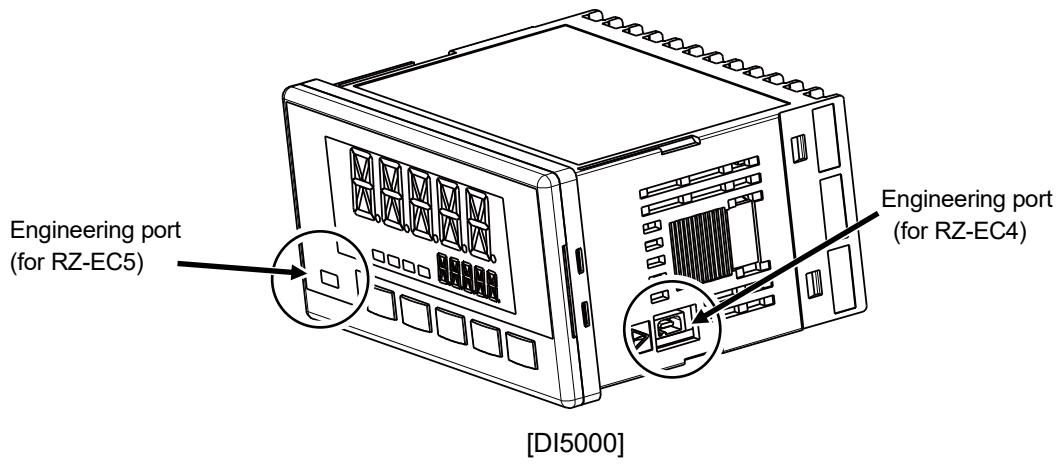

\*Set port at "Port switch (MODEt)".

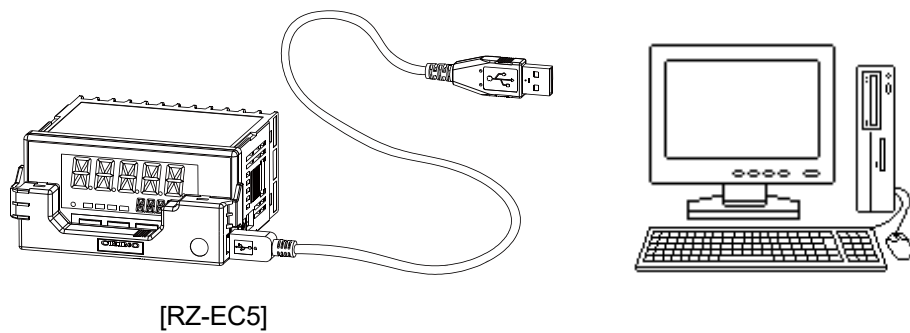
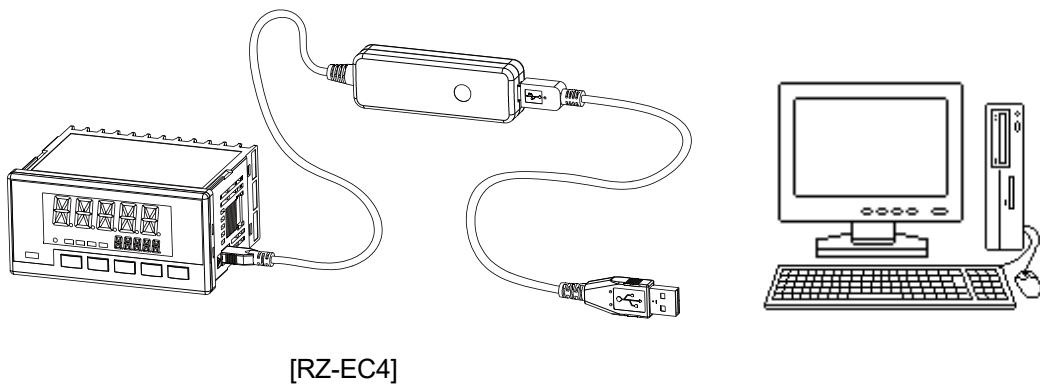

## DP1000G/ DP2000G/ DP3000G Graphic Program Controller/Setter

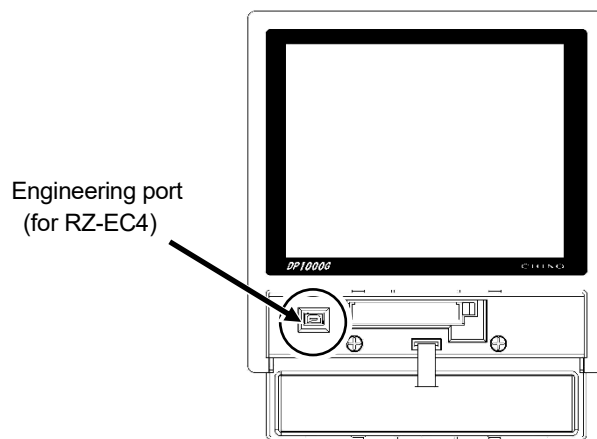

## AL4000/ AH4000 Hybrid recorder

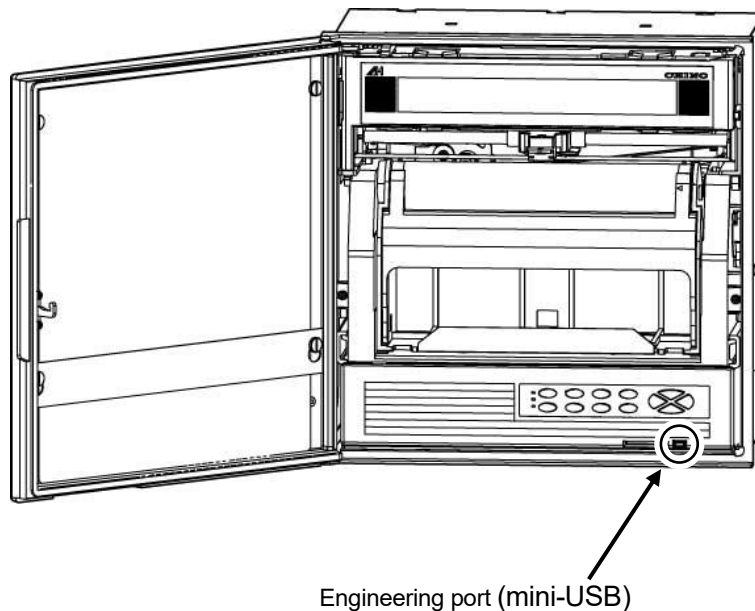
**Caution**

For controller/ setter/ alarm unit, do not use a cable other than dedicated engineering cable.

**Caution**

SB700 has the engineering port, but it does not support setting from the TRAMS. So use SB setting software.

**Caution**

Make sure to connect/ disconnect the engineering cable to the engineering port while the unit is energized.  
For its structure, engineering cable is for temporarily communication, not for normal communication connection use.  
For normal communication connection, order specification with communication interface at purchase and connect permanently from back terminal.

## 1-9 TRAMS operating condition

Use TRAMS under following environment.

Preparation	Contents/conditions	
PC	CPU	1GHz or more. 32 bit or 64 bit
	Memory	1GB or more (32bit), 2GB or more (64bit)
	Hard disc	2GB or more free hard disc space
	Removable disc	<p>For KR2000, KR3000, KR2S / 3S, KR2D / 3D, LE5100, LE5200 Data acquired by the equipment (*.krf, *.kpf, *.csv, *.l5f) or parameter setting file (*.krs, *.kps) can be saved to CF card. To use these data on PC, use CF card reader etc. to connect to the PC.</p> <p>For AL4000, AH4000 Data and setting parameter acquired by the equipment can be saved to SD card. To use these data (*.a4f, *.txt, *.a4s) on PC, SD card reader etc. to connect to the PC.</p> <p>For DP1000G, DP2000G, DP3000G Setting filer (*.ds1, *.ds2, *.ds3) and program pattern file (*.dp1, *.dp2, *.dp3) can be saved to CF card. To use these data in PC, use CF card reader etc. to connect to the PC.</p> <p>*For SC5000, data (*.krf, *.csv) can be saved to PC using FTP function.</p> <p>*Above files, TRAMS readable files are *.krf file, *.kpf file, *.a4f file, *.l5f file, *.krs file, *.kps file, *.a4s file, *.ds1/ ds2/ ds3 files and *.dp1/ dp2/ dp3 files.</p>
OS	<p>Windows 10(32bit/64bit) Windows 11(64bit) *.NET Framework4.7.2 or latter version shall be able to be installed to above OS.</p>	
Install	.NET Framework4.7.2	
	<p>Microsoft Excel 2016 /2019 /2021 *If it is not installed, daily report output, monthly report output, and data list output function are restricted.</p>	
	Windows Media Player	
Display	Screen resolution 1024x768 or more	

# 1-10 Software configuration

\*In configuration item, number inside parentheses is reference chapter number and section number.

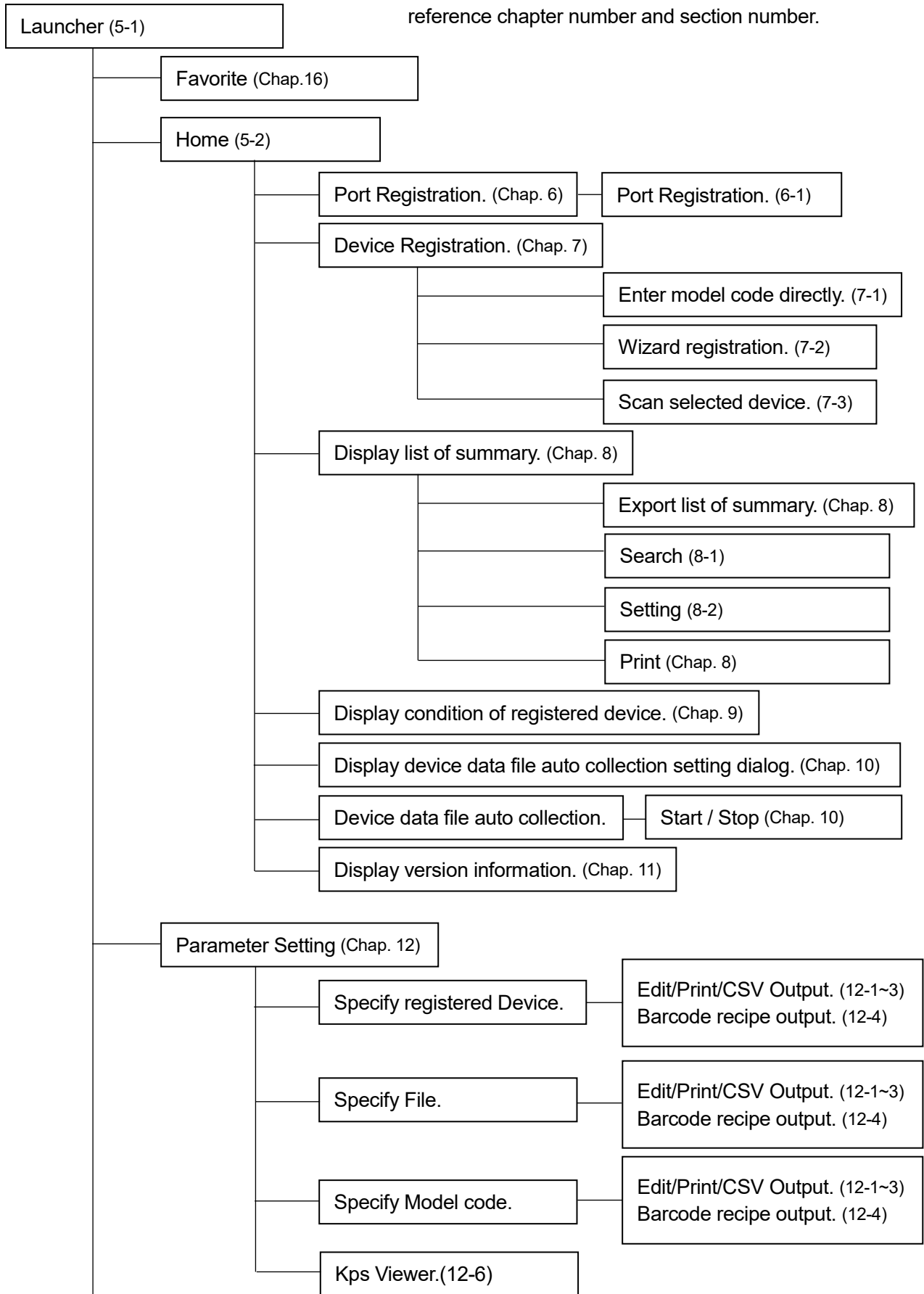

(Continued on next page.)

(Continuation from previous page.)

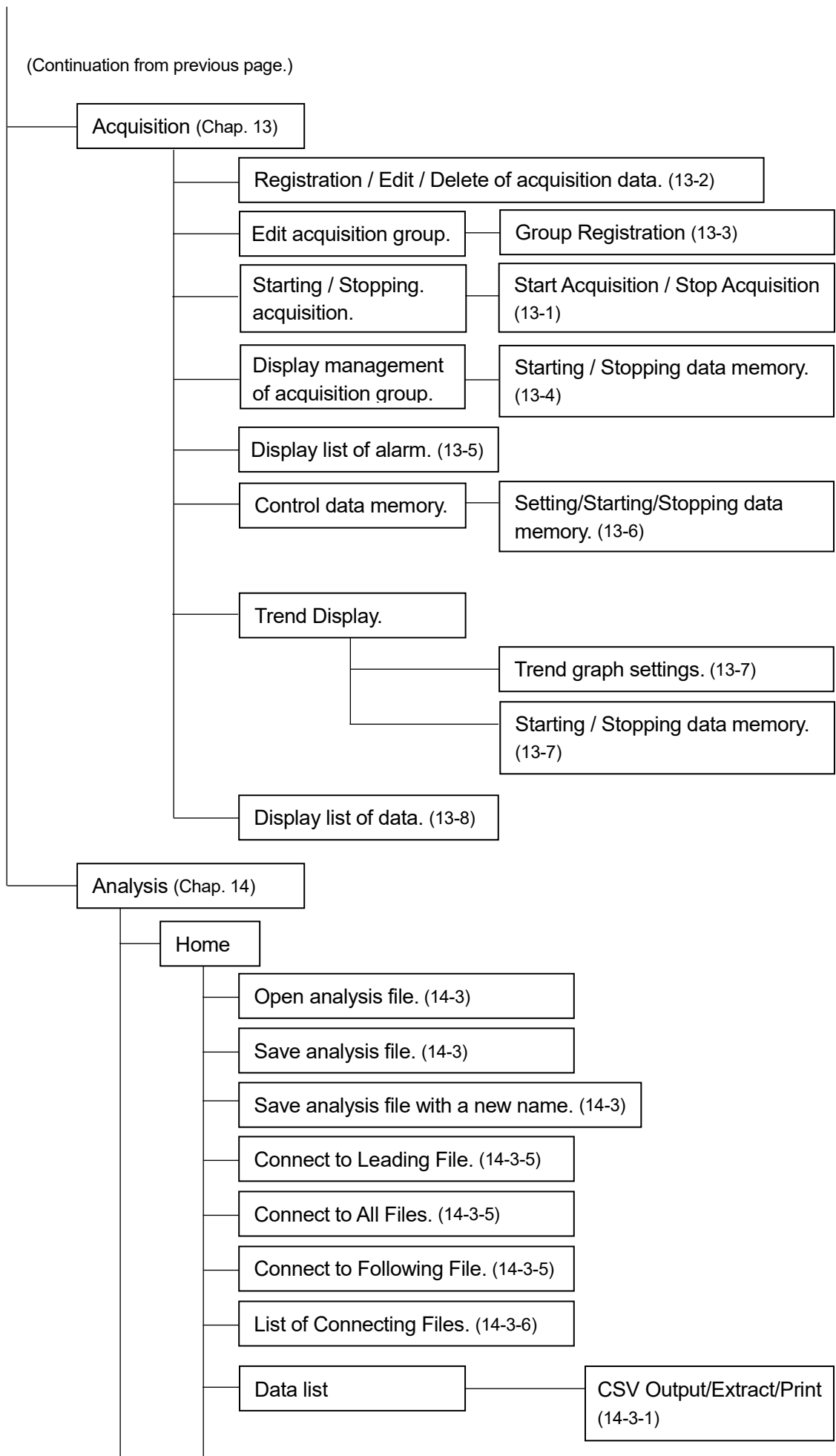

(Continued on next page.)

(Continuation from previous page.)

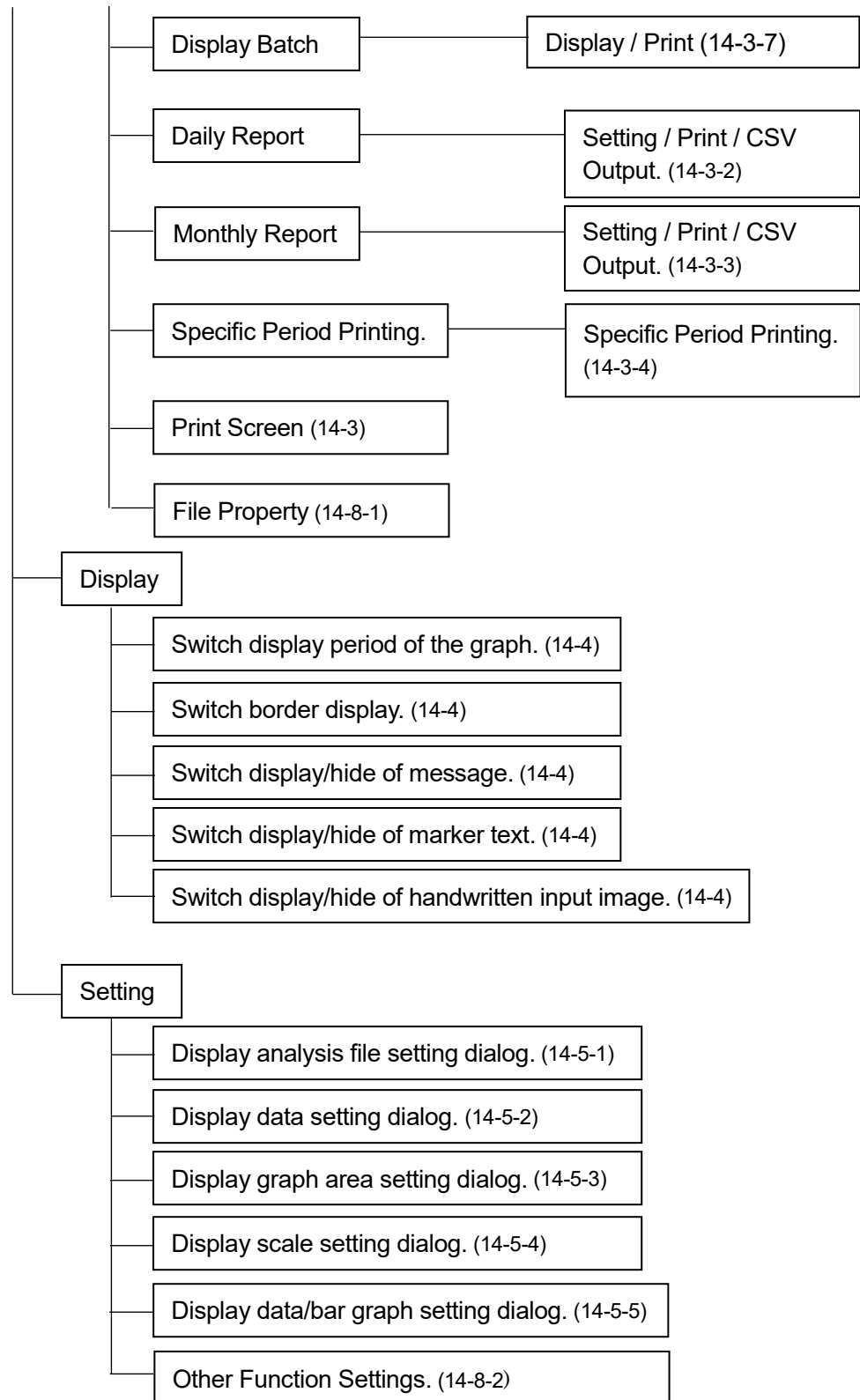

## 2 How to setup

### 2-1 Installation

#### 2-1-1 New installation

Install TRAMS to PC before use.

Follow the procedures for installation below.



### Caution

At the time of installation, it is necessary to log in to PC as administrator.  
Installation can not be done by general user.

#### <Procedures>

1. Start up installer

Log in to the Windows as administrator and run 'setup.exe'.

2. License agreement.

Installation of "Microsoft .NET Framework 4" is required in advance.  
Click [Accept] button.

**\*If it is installed, the dialog may not be displayed.**

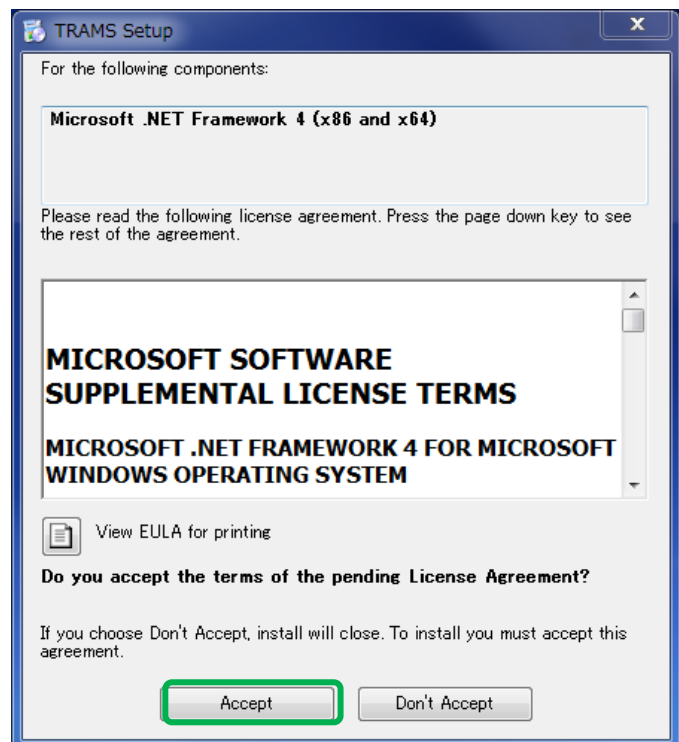

**\*Note on license agreement**

If this dialog is displayed, check that the PC is connected to the network. Execute the installation again in the condition of connected to the network.

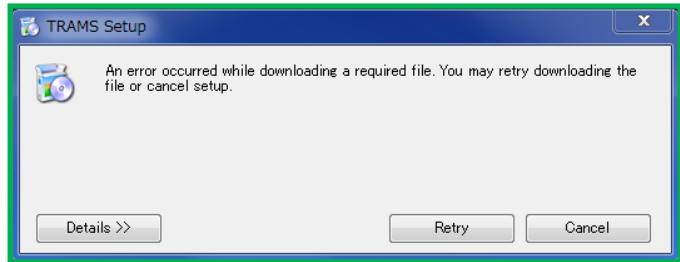
**3. Start the Installation Wizard.**

TRAMS Setup Wizard dialog is started.

Click [Next] button.

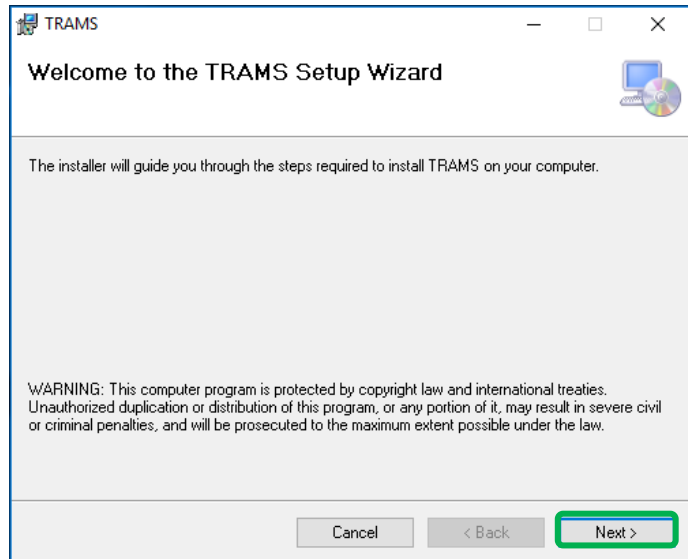
**4. Select Installation Folder.**

On Select Installation Folder dialog, select [Folder] and [User]. Click [Next] button.

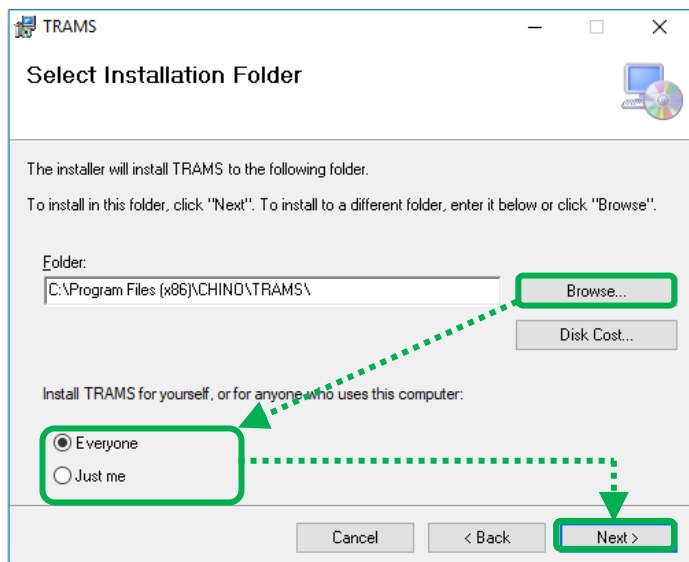



## 5. Confirm the Installation.

On Installation Confirmation dialog, click [Next] button.

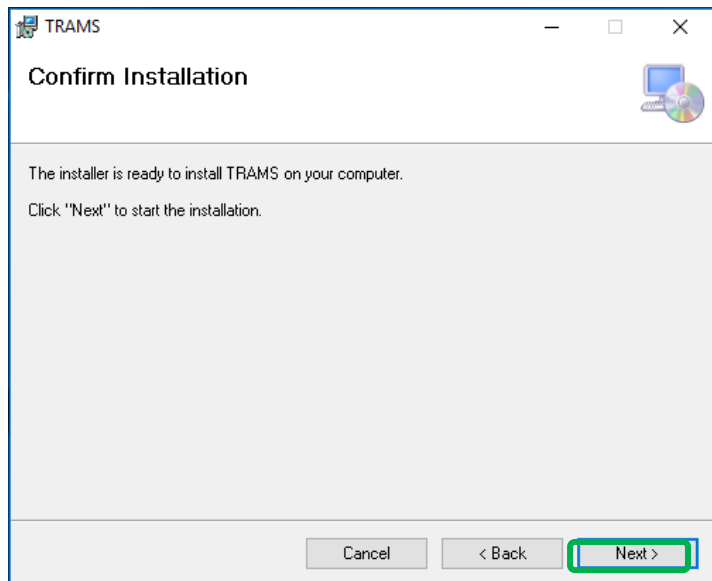

## 6. Licence for change

Before installation start, user account control dialog is displayed.

If no problem is arisen, click [Yes] button and proceed to installation.

\*Display of user account control dialog differs depending on OS/ settings etc.

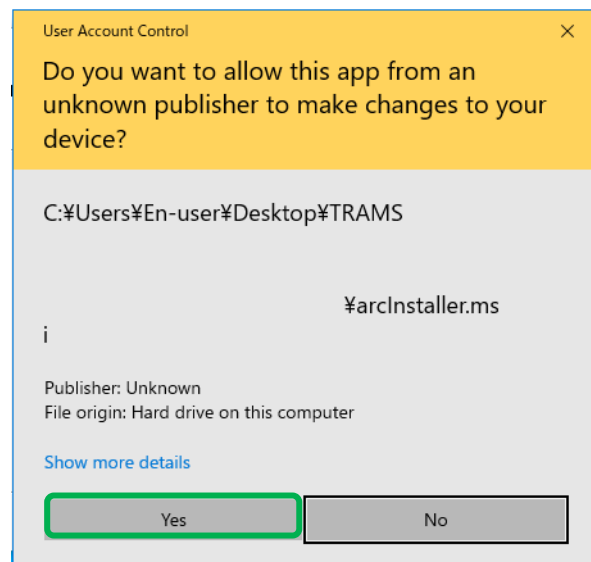

## 7. Enter license key

To use as a free-of-charge version, click the [Use as Free Version] button. In that case, no license key is required.

A license key must be entered to use the software as a TUS report output function version (paid). The license key is attached to the front of "TRAMS TUS Report Output Function" CD case you purchased. Click [Next].

\*The license key entry window may be hidden behind.

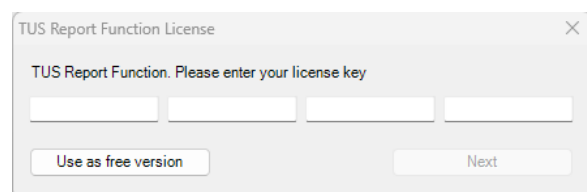

## 8. Start installation

The installation is started.

The dialog indicating the progress of the installation appears. Wait until the installation completes.

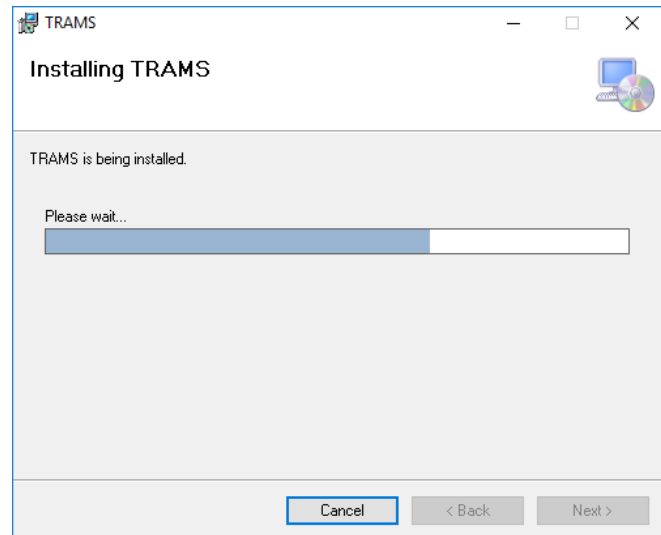

## 9. Complete the installation

Installation Complete dialog appears.

Click [Close] button to finish.

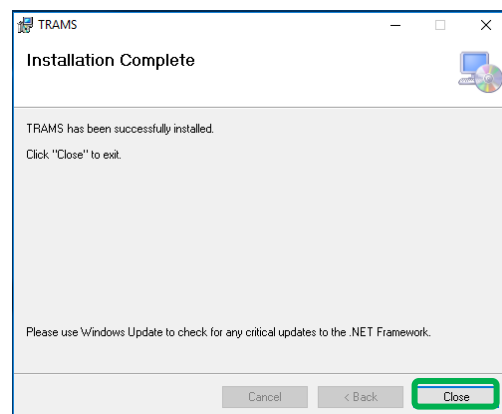

### 2-1-2 Installation at the version upgrade

TRAMS may upgrade to a new version to add new functions and/or fix failures.

Follow the procedures for version upgrade below.

#### <Procedures>

1. Uninstall current version (refer to the section 2-2)
2. Install new version (refer to the section 2-1-1)

### 2-1-3 Power supply control

For a continuous run, [Power supply option] setting change is necessary.

◆ <For Windows 11>

Open [Sleep] by clicking [Start]-[Setting]-[System]-[Power]-[Screen & sleep] in order, and select [Never].

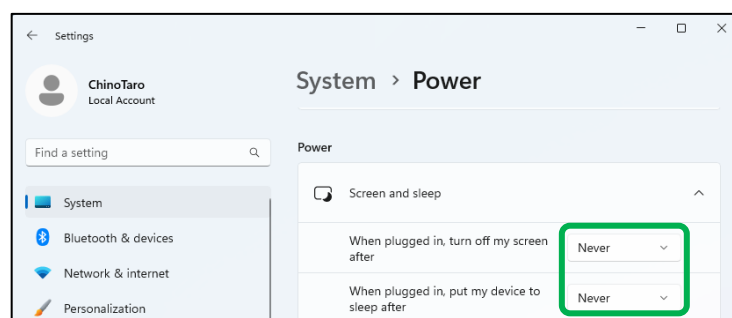

## 2-2 Uninstallation

This section describes how to delete TRAMS from the hard disk.

Before starting the uninstallation, exit from all the programs that are related to TRAMS.

### <Procedures>

1. Open Control Panel.  
Open Control Panel.

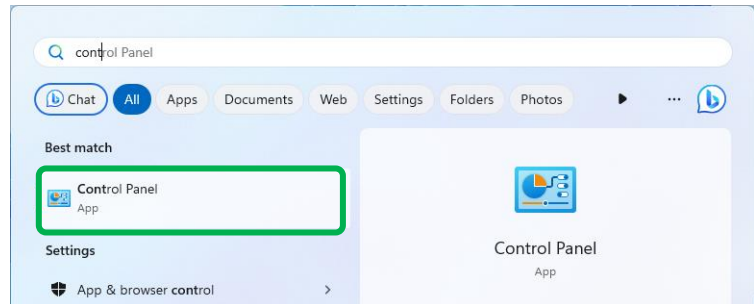

2. Click [Uninstall a program].  
After the Control Panel appears, click [Uninstall a program].

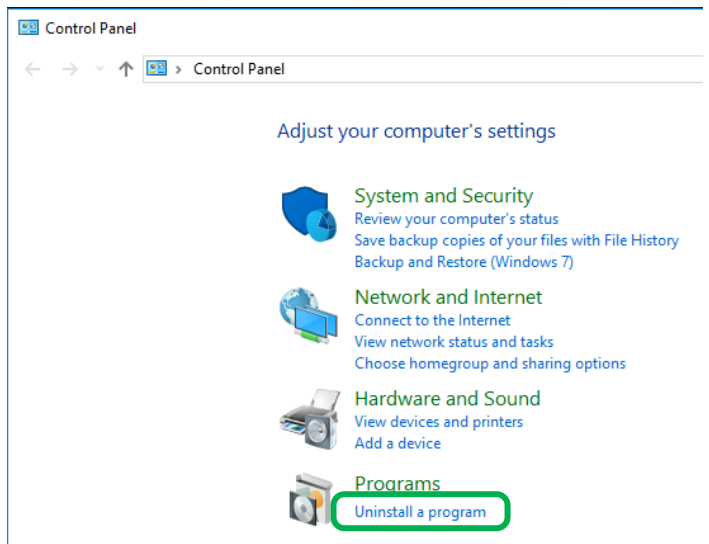

### 3. Delete [TRAMS].

Select [TRAMS] from a list, then click [Uninstall].

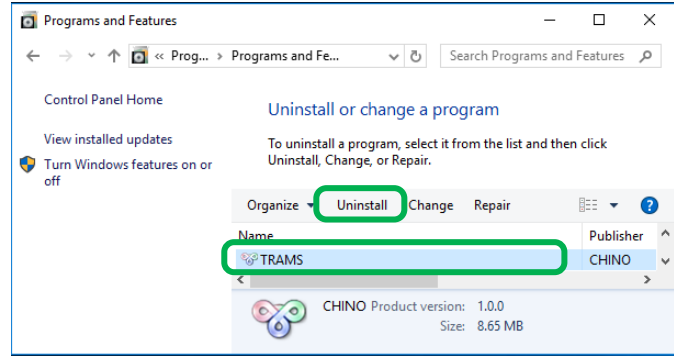

### 4. Click [Yes].

Click [Yes] on Program and Features dialog

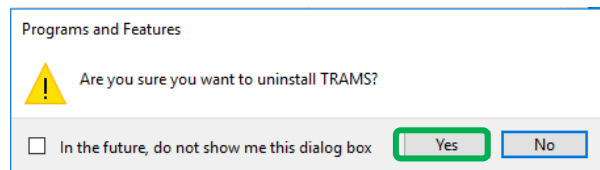

### 5. Licence for change

Before uninstall starts, user account control dialog is displayed.

If no problem is arisen, click [Yes] button and proceed to uninstallation.

**\*Display of user account control dialog differs depending on OS/ settings etc.**

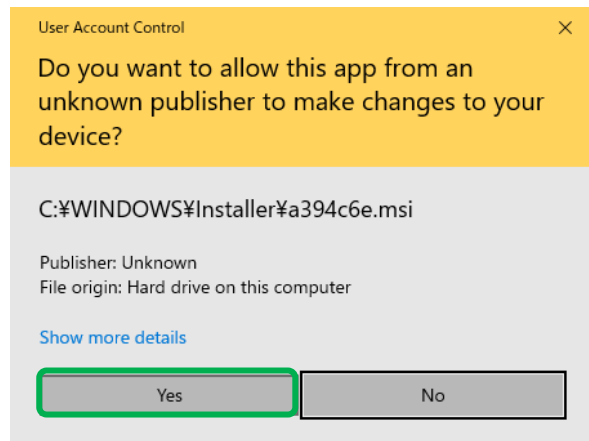

### 6. Start the uninstallation.

The uninstallation is started.

The dialog indicating the progress of the uninstallation appears.

Wait until the uninstallation completes.

When the uninstallation is completed, the dialog shown right is closed automatically.

**\*At this point, a folder related to the software still remains. To delete the folder completely, delete the related folder "TRAMS" by Windows Explorer. The location of the folder is indicated on 2-3. Folder structure.**

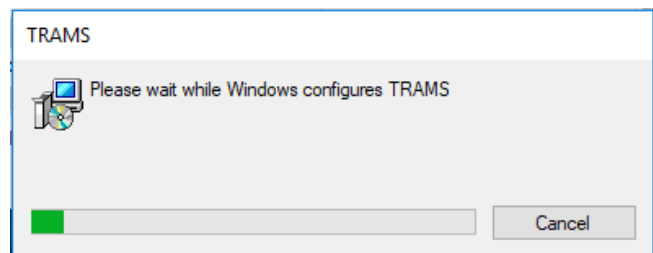

## 2-3 TRAMS folder structure



### Caution

It may cause error or system failure if executes a program in the folder alone, or moving, deleting or changing name of file or folder.

This section describes how to delete TRAMS from the hard disk.

Before starting the uninstallation, exit from all the programs that are related to TRAMS.





#### [Folder location for TRAMS]

Type	Folder location (default )
Program folder	C:\Program Files (x86)\CHINO\TRAMS (for 64bit) C:\Program Files\CHINO\TRAMS (for 32bit)
Data folder	C:\ProgramData\TRAMS

#### [TRAMS program folder structure]





C:\Program Files (x86)\CHINO\TRAMS (for 64bit)

C:\Program Files\CHINO\TRAMS (for 32bit)

Folder name	Contents
 TRAMS	The save destination is designated at installation. The default save destination is as follows. C:\Program Files (x86)\CHINO\TRAMS (for 64bit) C:\Program Files\CHINO\TRAMS (for 32bit) A folder is prepared automatically under the folder designated at the installation. <b>Do not move, delete, rename files under this folder, otherwise TRAMS will not start normally.</b>
 Device	This folder loads .dll files.
 ExcellInterop	This folder loads .dll files for Excel control.
 Template	This folder loads sample files of daily reports and monthly reports. You can copy this sample file to another location and use it as a report file. Do not delete these files by mistake.

#### [TRAMS data folder structure]

C:\ProgramData\TRAMS

Folder name	Contents
 TRAMS	<b>Do not move, delete, rename files under this folder, otherwise TRAMS will not start normally.</b>
 Config	This folder loads setting information (xml file) of the entire software.
 Group1 to 10	This folder loads trend settings and data memory setting information for each group. (Folder does not exist if unused.)
 TrendStorage	This folder loads trend data files. These data can only be confirmed on the trend graph screen. (User can not manipulate this graph data )

# 3 Startup and Exit of TRAMS

## 3-1 Startup

This section describes how to startup TRAMS.

### <Procedures>

#### 1. Start TRAMS

Click in following order [Start]→[All apps]→[TRAMS], TRAMS starts up.

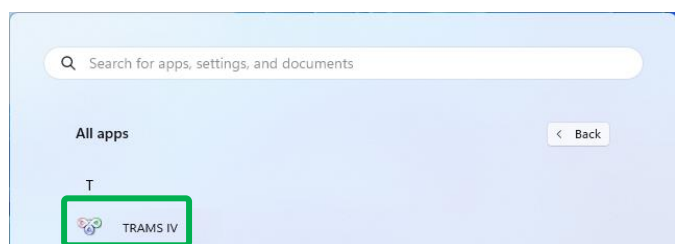
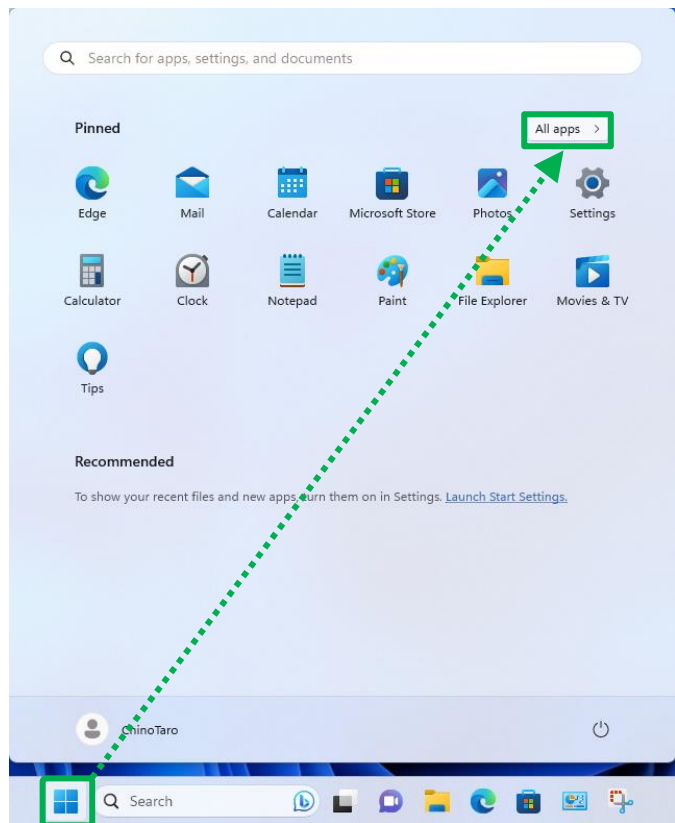

#### 2. Display at initial startup

At initial startup, message of "Specify TRAMS as the default application for supported files." is displayed.

When [YES] is clicked, the default application becomes TRAMS. When TRAMS is not running, it can be opened by double-clicking on the file.

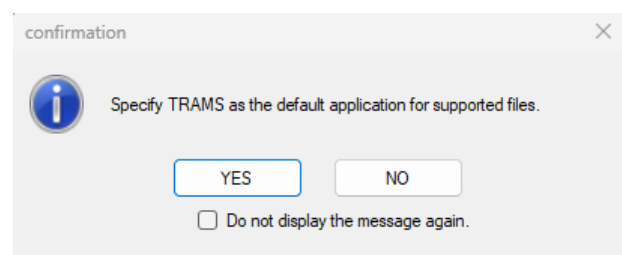

If you clicked [YES] mentioned above, the message "Please restart the OS" is displayed. To set default application as TRAMS, it is necessary to restart the OS.

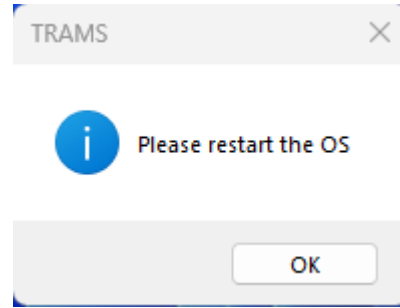

---

## 3-2 Exit

---

This section describes how to exit TRAMS.

### <Procedures>

Click [ X ] on the right end of the title bar and close the Main Operation window.

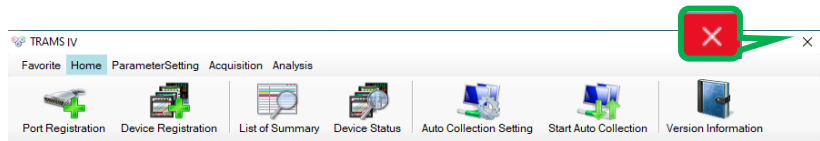

## 4 How to Operate

### 4-1 Flow of operation

#### <Procedures>

#### 1. Startup TRAMS

Launcher is displayed when TRAMS is started.

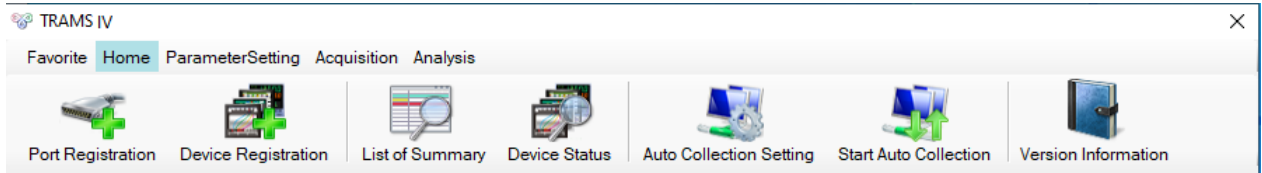

#### 2. Function selection

5 functions can be selected from launcher.

From left of the menu bar [Favorite], [Home], [Parameter setting], [Data acquisition] and [Data analysis].

By clicking each menu button, tool button under the menu bar changes to corresponding function's tool buttons.

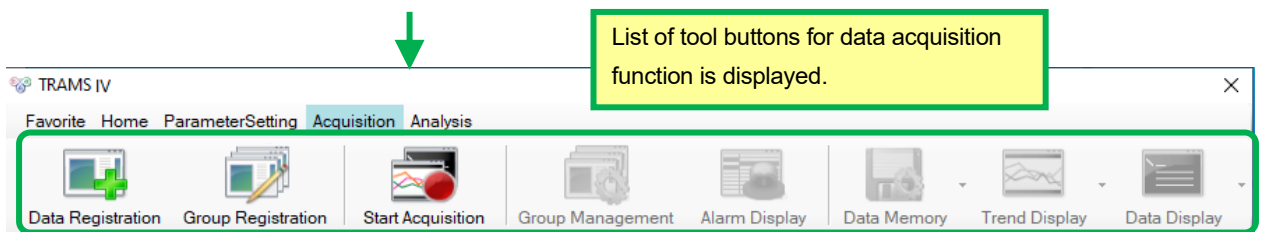
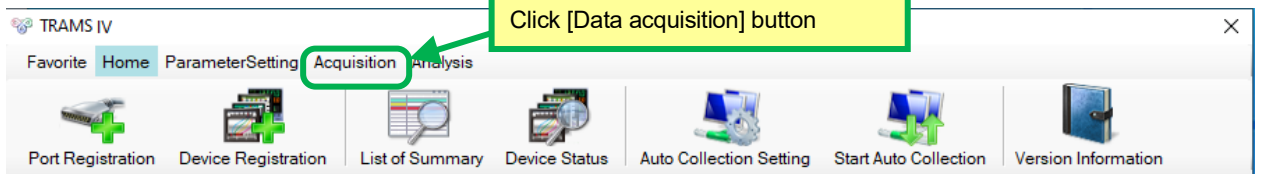



### 3. Startup various functions

After function is selected, click tool button under the menu bar.

By clicking the tool button, applicable function/ display starts up.

**\*Maximum 10 displays can be opened up. However, following displays are exceptional.**

- [4-2-1. Port registration display]
- [4-2-6. Version information display]
- [4-4-1. Data registration display]
- [4-4-2. Group registration display]

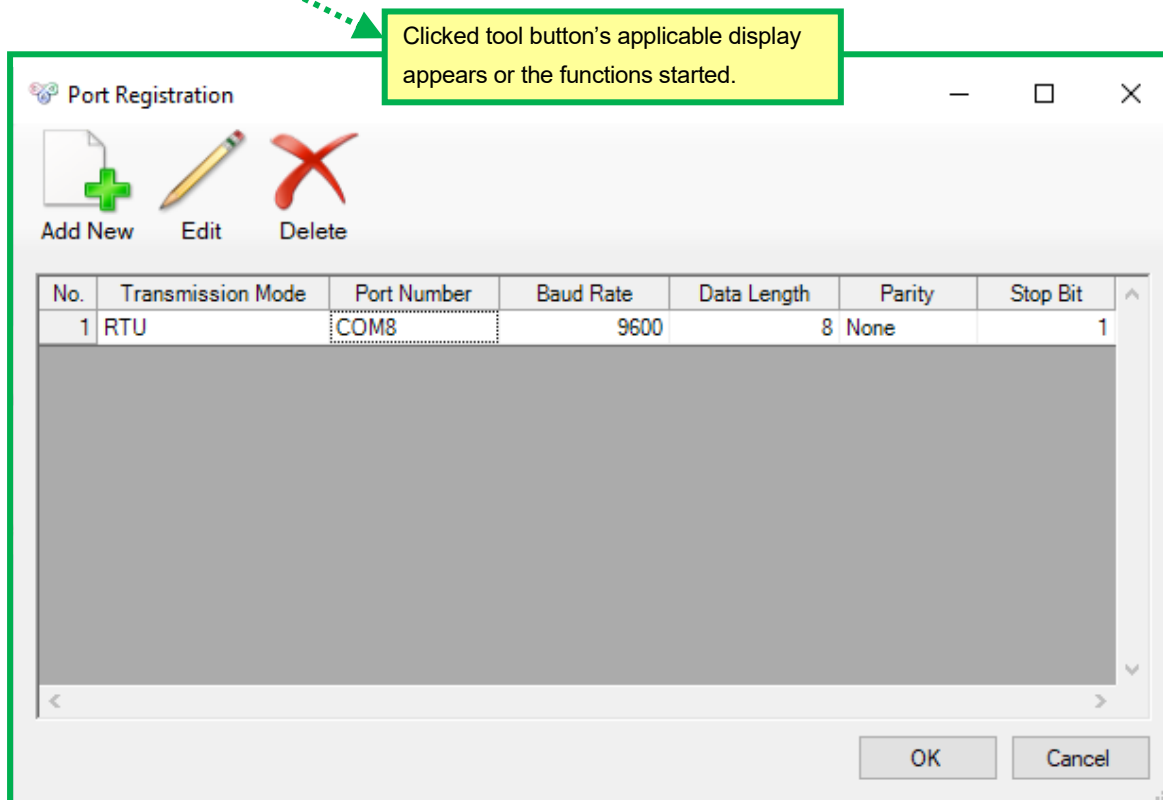
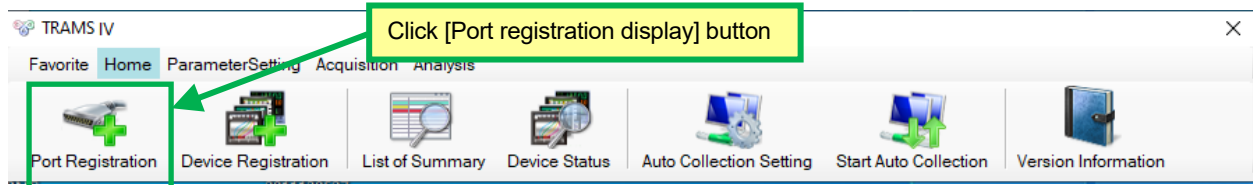

### 4. Exit TRAMS

Close the launcher.



## Caution

**By closing the launcher, even though setting/ acquisition/ analysis function is running, the operation is forcibly terminated. Save settings and data before closing the launcher.**

## 4-2 Operation of home

Home functions as displaying registration display of setting information or status monitoring display.

### <Names of home functions on Launcher>

This is displayed by following procedure.

[TRAMS]→[Home]

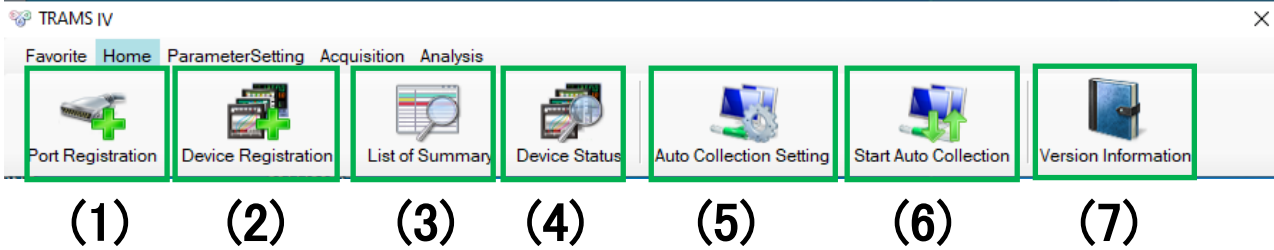

Num.	Number	Descriptions	Reference
(1)	Port registration	Displays port registration window. Performs registration/ editing/ deleting of port setting.	Chap. 6
(2)	Device registration	Displays device registration window. Performs registration/ editing/ deleting of connected device.	Chap.7
(3)	Summary display	Displays summary and performs its display setting.	Chap.8
(4)	Registered device status display	Displays registered device's acquisition communication status. It also displays registered device name, current communication status, model and port.	Chap.9
(5)	Device data file auto correction setting	Performs detail setting of acquiring data file from a device with FTP server function (KR series).	Chap.10
(6)	Device data file auto collection	Starts and ends data file acquiring from a device with FTP server function (KR series).	
(7)	Version information display	Displays TRAMS version and connected device's DLL version information.	Chap.11

## 4-3 How to open a file

To open a parameter file or a data file, drag & drop file icon to an icon on the launcher or data analysis display (only for data file).

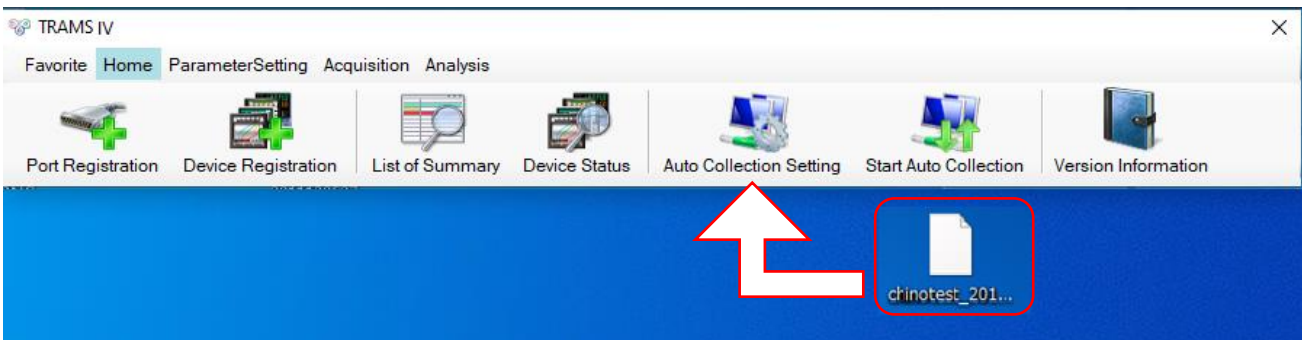

If the file is associated:

The file can be opened by double-clicking when TRAMS is not running.

## 5 Initial settings and functions

### 5-1 Initial settings

Required setting differs depending on contents you want to perform.

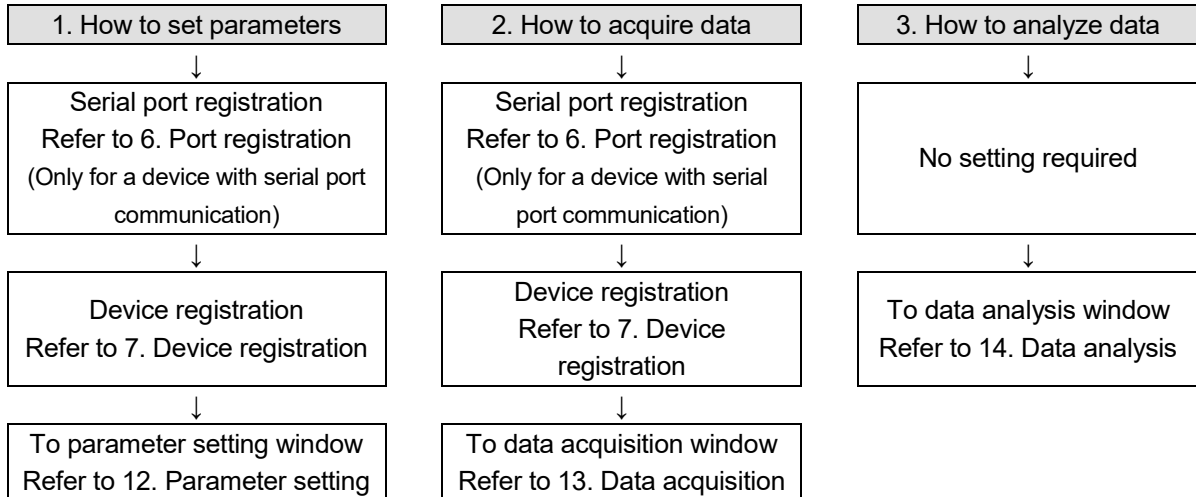

How to connect device and PC: Only Ethernet⇒ Serial port registration is unnecessary.

**There are 3 ways to register devices.**

1. Input model manually.
2. Input model from wizard window.
3. Scan connected devices and load models.

When required settings are done, operation on various windows become available.

## 5-2 TRAMS Functions

TRAMS can perform followings for registered devices.

1. Check and change settings of device (Parameter setting)		
	(Preparation 1-1) Registration is necessary only for performing serial communication. Perform serial port registration.	⇒6. Port registration
	Load device parameters and check setting contents.	⇒12-1-1. Device parameter loading and writing
	Change parameter loaded from a device and write to the same device.	⇒12-1-1. Device parameter loading and writing
	Save parameter loaded from a device as a file.	⇒12-1-2. Device parameter file saving
	Load saved file, change its contents and save.	⇒12-2-1. Loading and writing device parameter file(1)
	Startup parameter setting window from device selection wizard, change contents and save.	⇒12-2-1. Loading and writing device parameter file(2)
	Load saved file, change its contents and write to the device.	⇒12-2-1. Loading and writing device parameter file(3)
	Output recipe for KR2S/ KR3S/ KR2D/ KR3D barcode recipe output function (optional).	⇒12-4. Barcode recipe output
2. Data acquisition		
Red letters are required items.		
	(Preparation 2-1) Register data Perform alarm settings (alarm settings are optional)	⇒13-2. Data registration window
	(Preparation 2-2) Register data to groups	⇒13-3. Group registration window
	(Preparation 2-3) Start data acquisition (Note 1) If not starting data acquisition, data acquisition related operation onward (trend graph display, numerical data display etc.) can not be done. For details, refer to 13-1. Operation of data acquisition.	⇒13-1. Data acquisition operation
	Displays trend graph of acquired data.	⇒13-7. Trend graph display
	Displays real-time data of acquired data as numeric value.	⇒13-8. Real-time data list display
	Saves acquired data in a file. (Note 2) For difference of data acquisition and data memory, refer to 13-1. Operation of data acquisition.	⇒13-6. Data memory operation or ⇒13-4. Acquired group management window
3. Use of data acquired by TRAMS and data acquired by devices (Data analysis)		
	Displays data list.	⇒14-3-1. Data list display window
	Output daily report, save CSV file	⇒14-3-2. Daily report output window
	Output monthly report, save CSV file	⇒14-3-3. Monthly report output window
	Specify period and print trend graph.	⇒14-3-4. Period specific printing window
	Displays batch information of KR binary data file (.krf, .kpf) and print out.	⇒14-3-7. Batch display
	Prints display image.	⇒14-3. Operation of home
	Name analysis file and save.	⇒14-3. Operation of home

## 6 Port registration

To communicate using serial port, register, change, delete port at port registration window.

### <Names of Parts on Port registration window>

The window is displayed by following operation.

[TRAMS]→[Home]→[Port registration]

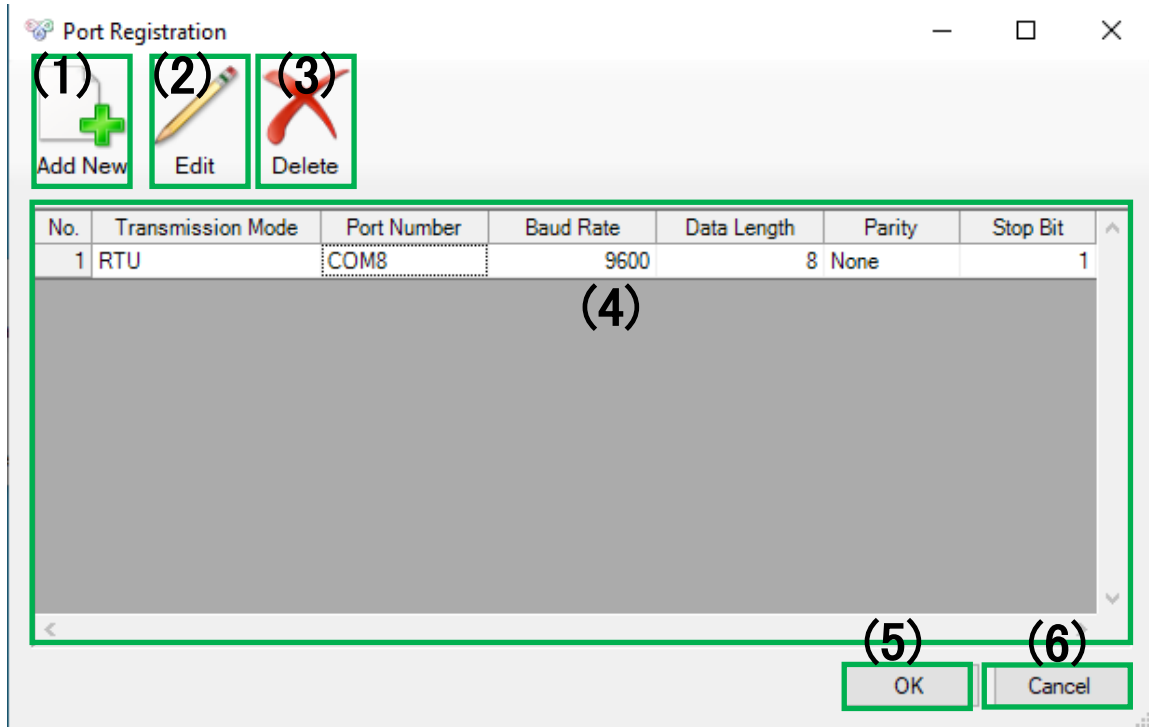

Num.	Name	Descriptions	Reference
(1)	Add New	Displays port edit window. Only 1 port can be registered.	6-1
(2)	Edit	Displays edit window for registered port setting information. *Only for editing, double-clicking on a part of (4) Registered port list can display port editing window.	6-1
(3)	Delete	Deletes selected port from registered port setting information.	
(4)	Registered port list	List of currently registered port setting information is displayed.	
(5)	OK	Add New·Edit·Delete contents will be reflected.	
(6)	Cancel	Add New·Edit·Delete contents will be canceled.	

## 6-1 Port edit window

Performs port registration and edit port setting information.

### <Names of Parts on Port edit window>

The window is displayed by following operation.

[TRAMS]→[Home]→[Port registration]→[Edit]

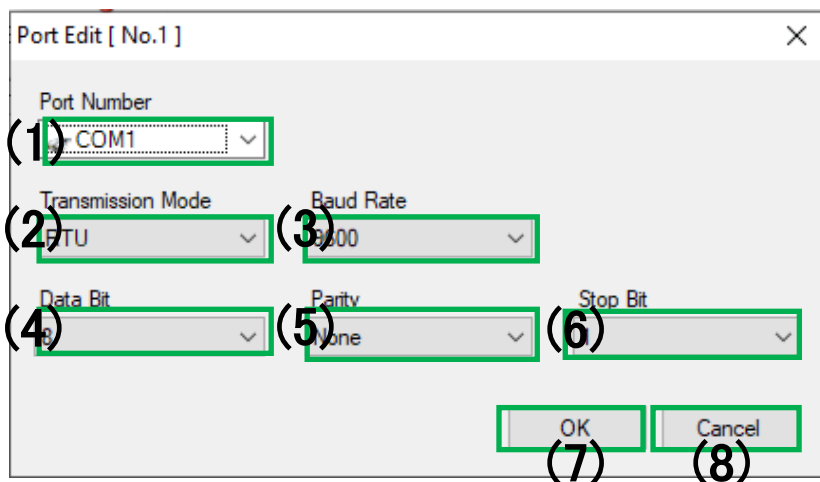

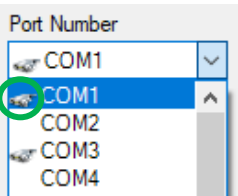
Num.	Name	Descriptions
(1)	Port number	Select port number from COM1 to COM256. *For available port number, following icon is displayed.    Or from control panel⇒device manager, check port to use.
(2)	Transmission mode	Select one of RTU/ ASCII.
(3)	Baud rate	Select from 9600/ 19200/ 38400.
(4)	Data bit	Select one of 7/ 8.
(5)	Parity	Select form None/ Even/ Odd.
(6)	Stop bit	Select one of 1/ 2.
(7)	OK	Reflect edited port setting information to port registration window.
(8)	Cancel	Cancels edited port setting information. If it is new registration, it cancels the addition, and if it is editing of registered port setting, it returns to the status before editing.

\*Match (1) to PC's communication setting and (2) to (6) to device's communication setting. If setting does not match to each other, communication can not be done.

# 7 Device registration

Performs registration, editing, and deleting of communicating device.

## <Names of Parts on Device registration window>

The window is displayed by following operation.

[TRAMS]→[Home]→[Device registration]

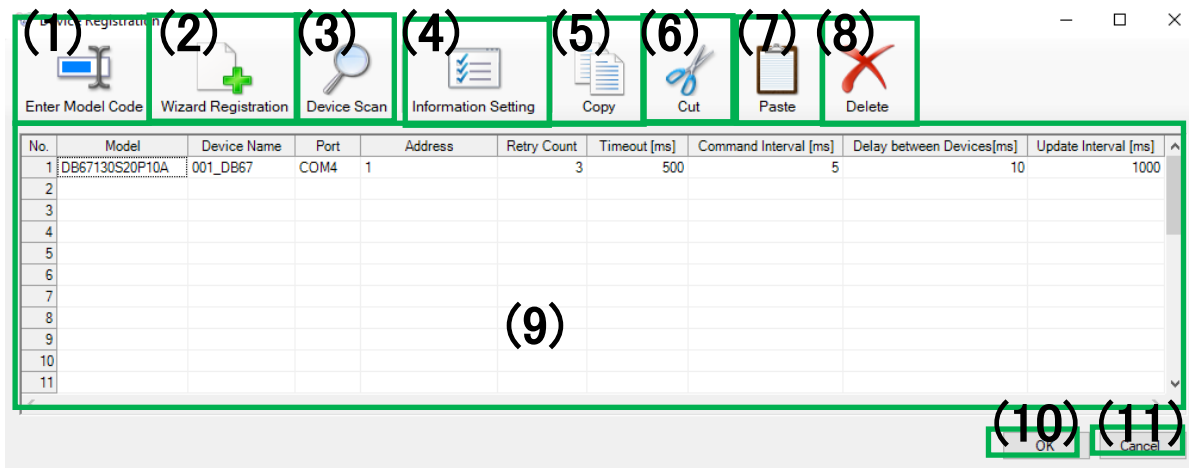

Num	Name	Descriptions	Reference
(1)	Mode code input	Displays model code input window. Directly input model code of the device intended to register.	7-1
(2)	Wizard registration	Device registration wizard starts. Specify device and various settings by choosing from selections.	7-2
(3)	Device scan	Displays device scan window. Specify communication setting and obtain model code from currently connected device.	7-3
(4)	Information setting	Displays device setting edit window. Edit detail setting information of device with confirmed model code.	7-4
(5)	Copy	Copies selected device information from list of registered devices. *Shot cut is available as Ctrl + C key.	
(6)	Cut	Cuts selected device information from list of registered devices. *Shot cut is available as Ctrl + X key.	
(7)	Paste	Paste device information obtained by (5) Copy or (6) Cut after the selected row. *Shot cut is available as Ctrl + V key.	
(8)	Delete	From registered device information, delete selected one. * Multiple deletions are available.	
(9)	List of registered devices	Displays list of currently registered device setting information. *Maximum 32 devices can be registered.	
(10)	OK	Add New·Edit·Delete contents will be reflected. *By clicking OK button, data is reflected to data registration window automatically. (Function is from TRAMSIII version 3.0.0.4)	
(11)	Cancel	Add New·Edit·Delete contents will be canceled.	

## 7-1 Model code input window

Window to obtain model code of device intended to register.  
Model code can be input from wizard window. (Refer to 7-2)

### <Names of Parts on Port edit window>

The window is displayed by following operation.

[TRAMS]→[Home]→[Device registration]→[Model code input]

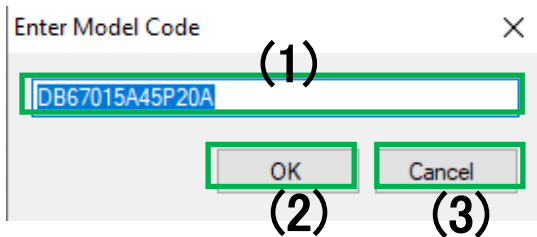

Num.	Name	Descriptions
(1)	Model code input column	Directly input model code intended to register.
(2)	OK	Create and register device information based on input model code. *If input model code is not included in feasible model codes of registration, it displays message saying registration is impossible.
(3)	Cancel	Ignore input model code and exit from model code input window.



## 7-2 Device registration wizard window

Model code of a device intended to register can be input from the wizard window.

Model code can be input from model code input window. (Refer to 7-1)

### <Names of Parts on 1. Device registration wizard window (Setting of Each Device)>

The window is displayed by following operation.

[TRAMS]→[Home]→[Device registration]→[Wizard registration]

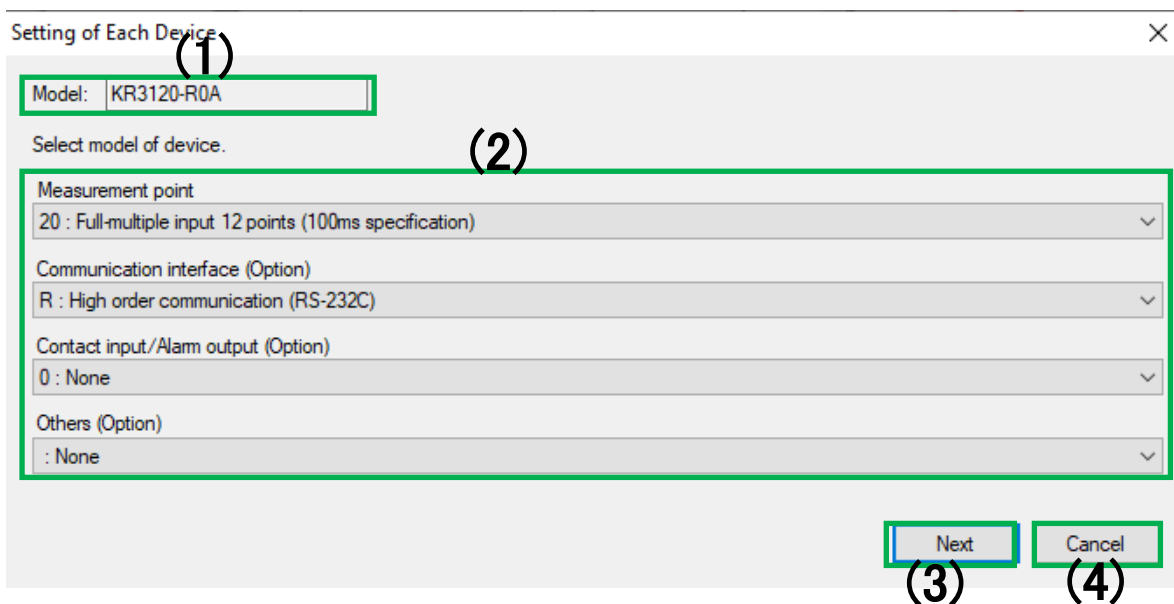

Num.	Name	Descriptions
(1)	Model code	Displays current model code. Contents changes by choosing (2) Model selection. *Direct editing cannot be done.
(2)	Model selection	It confirms model code by choosing each selection. Contents of (1) Model code changes by selecting each selection.
(3)	Next	To register device as specified model, it moves to confirmation window.
(4)	Cancel	Ignore specified model and exit from Device registration wizard window.

### <Names of Parts on 2. Device registration wizard (confirmation) window>

The window is displayed by following operation.

[TRAMS]→[Home]→[Device registration]→[Wizard registration]→[(3) Next]

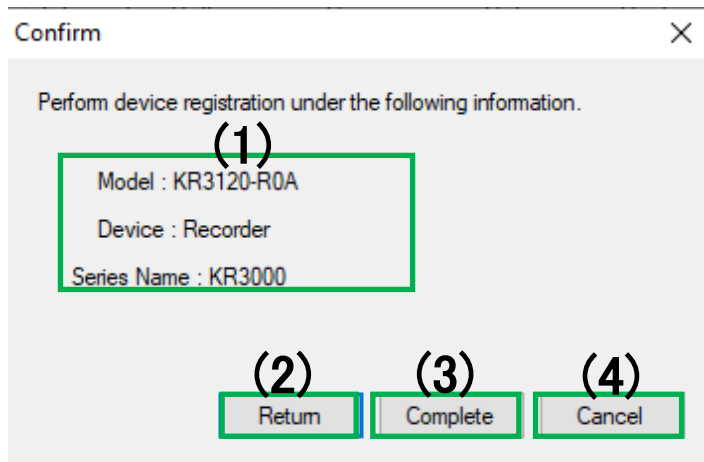

Num.	Name	Descriptions
(1)	Confirmation contents	Registering Model /Device/ Series Name are displayed.
(2)	Return	Returns to 2. Device registration wizard (model code selection) window.
(3)	Complete	Register device as confirmed contents.
(4)	Cancel	Ignore confirmed contents and exit from Device registration wizard window.

## 7-3 Device scan window

Scans device and registers detected device.

### <1. Names of Parts on Device scan window>

The window is displayed by following operation.

[TRAMS]→[Home]→[Device registration]→[Device scan]

The screenshot shows the 'Device Scan' window with the following elements:

- (1)** Condition Setting: Radio buttons for Serial (selected), USB, and Ethernet.
- (2)** Port: A dropdown menu showing 'COM4'.
- (2)** Device Address Range: Two input boxes, both containing '1', with 'to' between them.
- (2)** Retry Count: An input box containing '3'.
- (2)** Time Out [ms]: An input box containing '2000'.
- (3)** Scan: A button at the bottom right.
- (4)** Close: A button at the bottom right.

Num.	Name	Descriptions	Reference
(1)	Communication selection	Select communication method to connected device from serial communication/ Ethernet communication.	
(2)	Communication condition setting	Perform setting by each communication method specified at (1) Communication selection. Setting is saved and it is held at next time scan window is opened. (Function from TRAMSIII)	7-3<2.> 7-3<3.> 7-3<4.>
(3)	Scan	Starts device scan based on condition setting.	7-3<5.>
(4)	Close	Exit Device scan window.	

## <2. Names of Parts on Device scan window serial communication condition setting>

The window is displayed by following operation.

[TRAMS]→[Home]→[Device registration]→[Device scan]→[Select serial communication at Condition Setting]

Condition Setting

Serial    USB    Ethernet

Port (1)   Device Address Range (2)

COM4   1 to 1

Retry Count (3)   Time Out [ms] (4)

3   2000

Num.	Name	Descriptions
(1)	Port	Select a port form a list registered at 6. Port registration window. To decide which port to use, check control panel⇒device manager.
(2)	Device Address Range	Specify device address range of a device intended to scan from 1 to 99. Check each device's setting for device address. If engineering cable is used, device address is fixed to 1, so set the range 1 to 1. Initial value: 1 to 10
(3)	Retry Count	Specify communication retry count at scan from 0 to 50. Initial value: 3
(4)	Time out	Specify communication time-out time at scan from 0 to 10000. Initial value: 1000ms

\*For setting (3) Retry Count and (4) Time out

Check communication specification of connecting device, if there is no special specification, scan at initial value.

If the scan fails, set each value bigger and scan again.

### <3. Names of Parts on Device scan window Ethernet communication condition setting>

The window is displayed by following operation.

[TRAMS]→[Home]→[Device registration]→[Device scan]→[Select Ethernet communication at Condition Setting]

Num.	Name	Descriptions
(1)	IP Address Range	Specify IP address range of a device intended to scan. *Only for private IP address.
(2)	Port number	Specify port number of a device intended to scan from 0 to 65535. Check each device's setting for port number. This software does not support Modbus/ TCP (Port number 502).
(3)	Retry count	Specify communication retry count at scan from 0 to 50. Initial value: 3
(4)	Time out	Specify communication time-out time at scan from 0 to 10000. Initial value: 1000ms
(5)	Device address range	Specify the device address range of the device you want to scan. Initial value: 1 to 1

\*For setting (3) Retry Count and (4) Time out

Check communication specification of connecting device, if there is no special specification, scan at initial value.

If the scan fails, set each value bigger and scan again.

#### <4. Names of Parts on Device scan window USB communication condition setting>

The window is displayed by following operation.

[TRAMS]→[Home]→[Device registration]→[Device scan]→[Select USB communication at Condition Setting]

Condition Setting

Serial  USB  Ethernet

USB ID range

to  (1)

Retry Count  (2)

Time Out [ms]  (3)

Num.	Name	Descriptions
(1)	USB ID range	Specify USB ID range of a device intended to scan.
(2)	Retry count	Specify communication retry count at scan from 0 to 50. Initial value: 3
(3)	Time out	(3)Specify communication time-out time at scan from 0 to 10000. Initial value: 1000ms

\*For setting (2) Retry count and (3) Time out

Check communication specification of connecting device, if there is no special specification, scan at initial value.

If the scan is fails, set each value bigger and scan again.



### Caution

**USB communication is only supported by AL4000/ AH4000 parameter setting. (Supported from TRAMS IV) Furthermore, acquisition can not be done.**

#### <5. Names of Parts on Device scan window after scan window>

The window is displayed by following operation.

[TRAMS]→[Home]→[Device registration]→[Device scan]→[Scan]

Device Scan

Condition Setting

Serial  USB  Ethernet

Port: COM4

Device Address Range:  to

Retry Count:  Time Out [ms]:

(1)

Address	Model Code	Add	Setting	Web	FTP
1	DB201060*E-***	<input checked="" type="checkbox"/>	<input checked="" type="checkbox"/>	<input checked="" type="checkbox"/>	<input checked="" type="checkbox"/>

(2) (3) (4) (5)

Num.	Name	Descriptions
(1)	List of scan result	After scanning connected device, address which model code was loaded and model code of the device is displayed in a list. *The list is not displayed before the scan. *After the scan, device model code may be complemented as "*" (This is the case for a device which model code can be partially loaded by communication). If "*" is included in the model code, part of the device specification is not recognized correctly. In this case, set correct model code at device setting window after clicking Add button.
(2)	Add button	Add device information to the list of device registration using row of subjected model code.
(3)	Setting button	Targeting a device found by device scan, startup parameter setting window. *Refer to 12. Parameter setting.
(4)	Web connection button	Displays Web setting window of subjected device, using specified browser. *This operation is only available if subjected device supports Web setting.
(5)	FTP connection button	Displays FTP setting window of subjected device, using specified browser. *This operation is only available if subjected device supports FTP setting.

### <6. Names of Parts on Setting of Each Device window >

The window is displayed by following operation.

[TRAMS]→[Home]→[Device registration]→[Device scan]→[Scan]→[Add] or [Setting]

(\*This window is displayed for a device which model code can not be loaded by communication.)

Num.	Name	Descriptions
(1)	Model code	Model code of the device is displayed. *Moving to the next window is not available if displaying the window.
(2)	Model code selection column	Specify the model code which is not be able to load. If the model code is left blank, moving to the next window is not available. If it is not blank, but stated "*" The model is not specified.", the item is its initial value and it does not necessarily match to an actual status of the device, so check the value.

## 7-4 Device setting edit window

Performs editing device setting.

### <Names of Parts on Device setting edit window>

The window is displayed by following operation.

[TRAMS]→[Home]→[Device registration] → after selecting a device at device registration window, click [Information setting] or double-click device name.

Num.	Name	Descriptions
(1)	Device name	Specify device display name. Up to 30 letters can be input.
(2)	Retry count	Specify communication retry count from 0 to 50. Initial value:3 If communication is unstable, increase this number.
(3)	Time out [ms]	Specify response time out [ms] at communication from 0 to 10000. Initial value: varies on the device If the time-out time elapses, it is recorded in summary as time-out occurred.
(4)	Command interval [ms]	Specify transmission command interval [ms] at communication from 0 to 10000. Initial value: varies on the device. This is set according to communication specification of each device. If there is no special specification, leave it to the initial value. If time-out occurs, it may solves the problem by setting bigger command interval.
(5)	Delay between devices [ms]	Specify delay between devices [ms] at acquisition from 0 to 10000. Initial value: varies on the device This is set according to communication specification of each device.



Num.	Name	Descriptions
(6)	Update interval [ms]	Specify communication interval [ms] from 0 to 3600. Initial value: 1000ms  *Note: if update interval is set bigger than display interval or data memory interval, next trend graphing and data memory is done before data update. In this case, same data is recorded multiply. Set update interval value smaller than trend display interval and data memory interval.
(7)	Serial communication setting	Specify device address used for serial communication from 1 to 99. Select port from ports registered at 6. Port registration window. If engineering cable is used, it runs at device address 1.
(8)	USB communication setting	Specify ID used for USB communication.
(9)	Ethernet communication setting	Specify IP address used for Ethernet communication. Specify port number from 0 to 65535 and device address from 1 to 99. *This is only for private IP address.
(10)	OK	Reflects settings to device registration window.
(11)	Cancel	Ignores setting information and cancels reflecting setting contents.

\*Set values of (4) to (6) are used as following (Used at data acquisition communication).

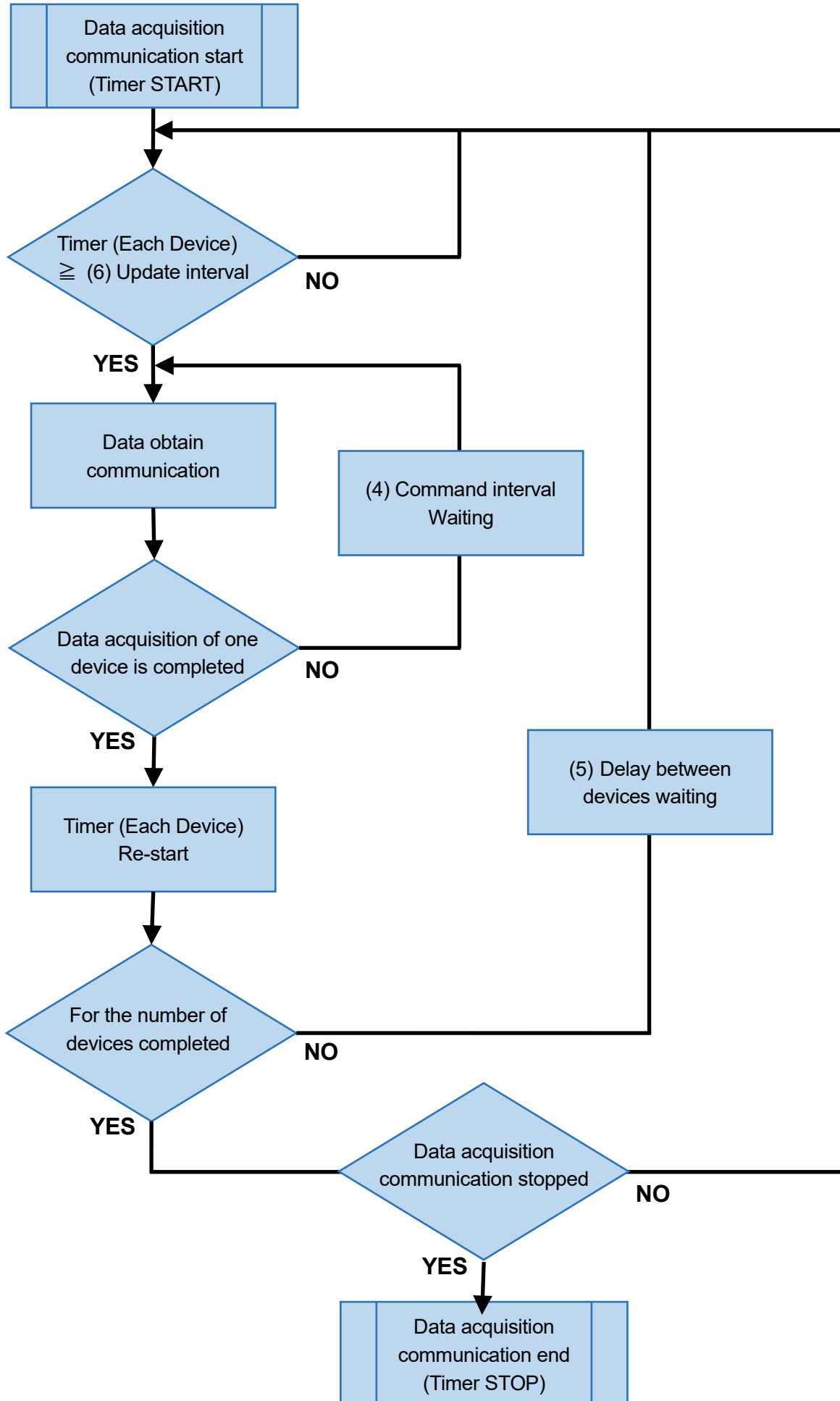

# 8 Summary display

Aggregate information in TRAMS and display as a list.

## <Names of Parts on Summary display>

The window is displayed by following operation.

[TRAMS]→[Home]→[List of Summary]

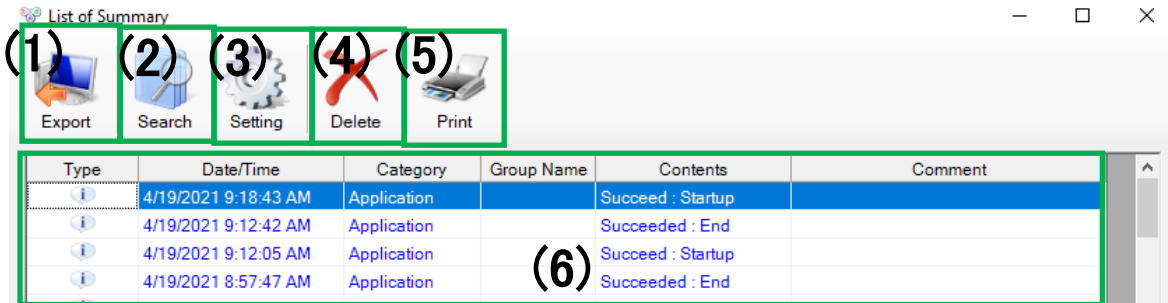

Num	Name	Descriptions	Reference
(1)	Export	Output file of currently displaying list of summary information. *Select file format from CSV/ text/ Excel.	
(2)	Search	Displays summary search window. By input search condition, specified summary information can be searched.	8-1
(3)	Setting	Performs various settings of summary display window.	8-2
(4)	Delete	Delete selected information from displayed summary information. *Deleting multiple information is available.	
(5)	Print	Print output currently displaying list of summary information. *Font changed in (3) Setting is not applied on the print.	
(6)	List of summary display	<p>Aggregates and displays fragment processing information in TRAMS. There are sort filter functions on each header of rows. By using following filter window, specify event to display.</p> <div style="border: 1px solid gray; padding: 5px; margin: 5px 0;"> <p>Type    Date/Time    Category    C</p> <p><input checked="" type="checkbox"/> (Select All)</p> <p><input checked="" type="checkbox"/> Error</p> <p><input checked="" type="checkbox"/> Information</p> <p><input checked="" type="checkbox"/> Warning</p> </div> <div style="border: 2px solid green; padding: 5px; margin: 5px 0; text-align: center;"> <p>By check box operation, change use or not the filter.</p> </div> <div style="border: 1px solid gray; padding: 5px; margin: 5px 0;"> <p>Apply    Clear    Cancel</p> </div> <p>*With check mark: display, without check mark: no displaying *Right click sub-menu: cancels sort, it cancels sort status by clicking *Comment to event can be written to the comment column (Cell directly editing, up to 100 letters)</p>	

## 8-1 Summary search window

Search summary.

### <Names of Parts on 1. Summary search window>

The window is displayed by following operation.

[TRAMS]→[Home]→[List of Summary]→[Search]

**\*Multiple condition specification other than event type may all searched by AND condition.**

The screenshot shows the 'Summary Search' window with the following elements highlighted and numbered:

- (1) Event type selection (Information, Alarm, Abnormal)
- (2) Start Point Date (2020/11/12 08:39:53)
- (3) End Point Date (2021/04/19 11:04:36)
- (4) Category (OS)
- (5) Group Name
- (6) Contents
- (7) Comments
- (8) Search All button
- (9) Search Previous button
- (10) Search Next button

Num.	Name	Descriptions	Reference
(1)	Event type selection	Specify event type. Information/ alarm/ abnormal all 3 types are specified as default value, so uncheck and invalidate the event if only specific event is intended to search.	
(2)	Start point date	Specify start date. It is enabled by marking the check box.	
(3)	End point date	Specify end date. It is enabled by marking the check box.	
(4)	Category	Specify summary event by choosing from selection or input directly. It is enabled by marking the check box. *Those which input values partially matches is searched.	
(5)	Group name	Specify group name by direct input. It is enabled by marking the check box. *Those which input values partially matches is searched.	
(6)	Contents	Specify contents by direct input. It is enabled by marking the check box. *Those which input values partially matches is searched.	
(7)	Comment	Specify comment by direct input. It is enabled by marking the check box. *Those which input values partially matches is searched.	
(8)	Search all	From list of summary, search all information matches to the condition and displays in list of search result.	8-1<2.>
(9)	Search previous	From list of summary, search information matches to the condition upward.	
(10)	Search next	From list of summary, search information matches to the condition downward.	

<Names of Parts on 2. Summary search window (List of search result display) >

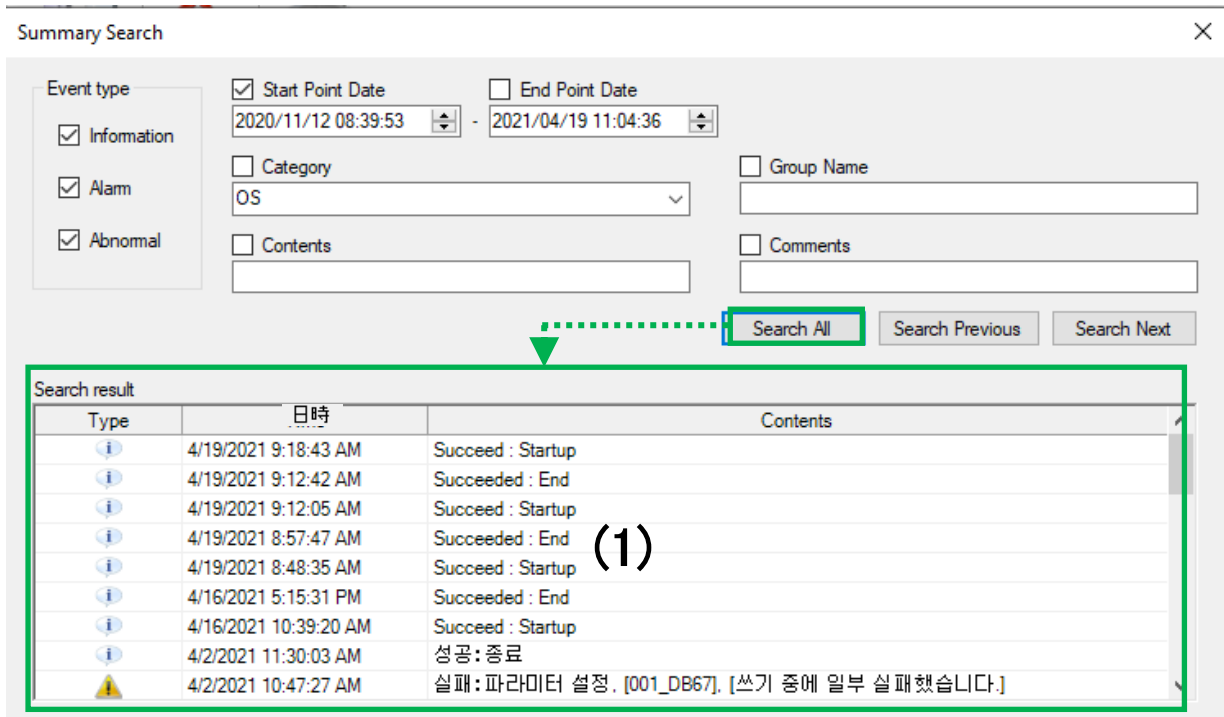

Num.	Name	Descriptions
(1)	List of search result display	List of search result matches to search condition (Category, group name, contents, comment may be match partially) is displayed all. By double-clicking on summary information on the list emphasizes and displays appointed summary information on the summary window. *Before clicking [Search all], (1) List of search result display is not displayed.

## 8-2 Summary setting window

Performs settings of summary setting window.

### <Names of Parts on summary setting window>

The window is displayed by following operation.

[TRAMS]→[Home]→[List of Summary]→[Summary setting]

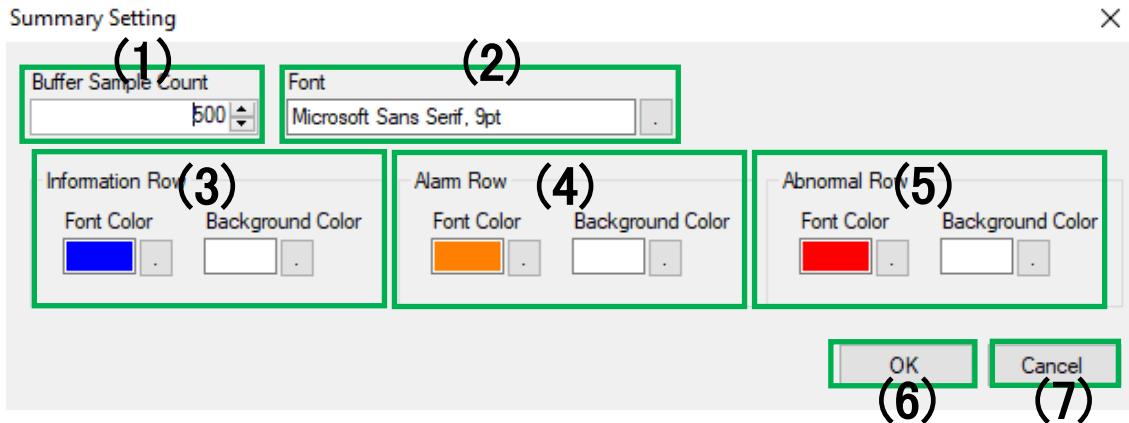

Num.	Name	Descriptions
(1)	Buffer sample count	Specify summary information number that TRAMS holds from 50 to 5000. Initial value: 500 Summary information in specified number is held although TRAMS ends and those are available to browse at next startup.
(2)	Font	Specify font information on summary display window.
(3)	Information row setting	Specify letter color and background color of information event summary.
(4)	Alarm row setting	Specify letter color and background color of alarm event summary.
(5)	Abnormal row setting	Specify letter color and background color of abnormal event summary.
(6)	OK	Reflects setting contents to summary display window.
(7)	Cancel	Ignores setting information and cancels reflecting setting contents.

## 9 Registered device condition display

Displays acquisition communication status of registered device in a list.

### <Names of Parts on registered device status display>

The window is displayed by following operation.

[TRAMS]→[Home]→[Device status]

Device Name (1)	Condition (2)	Model (3)	Port (4)
001_DB67	Stand-by	DB600	COM4 RTU 1
001_DB67	Stand-by	DB600	COM4 RTU 1
001_DB67	Stand-by	DB600	COM4 RTU 1
005_KR31	Stand-by	KR3000	192.168.254.254:11111:1
005_KR31	Stand-by	KR3000	192.168.254.254:11111:1
005_KR31	Stand-by	KR3000	192.168.254.254:11111:1

Num.	Name	Descriptions
(1)	Device name	Name that user choose at his/her will is displayed.
(2)	Condition	Current acquisition communication status is displayed by following classification. [Stand-by (background color gray)] Acquisition communication OFF, acquisition data not yet registered, or it is out of acquisition subject due to not belonging to acquisition group etc. [Normal (background color white)] Acquisition communication is ON, previous acquisition communication is completed normally. [Abnormal (background color red)] Acquisition communication is ON, Abnormality occurred on previous acquisition communication.
(3)	Model	Displays model of registered device.
(4)	Port information	Displays communication port information of registered device.

## 10 Device data file auto collection

When connecting to the device with the FTP server function (KR series), the device data file saved in the external memory inserted into the device can be collected automatically by a specific interval.

### <Names of Parts on device data file auto collection function setting widow>

The window is displayed by following operation.

[TRAMS]→[Home]→[Auto collection setting]

The screenshot shows the 'Device Data File Auto Collection Setting' dialog box. It is titled 'Device Data File Auto Collection Setting' and has a close button (X) in the top right corner. The dialog is divided into two main sections: 'FTP Setting' and 'Saving Setting'.  
 In the 'FTP Setting' section:  
 - 'Address' (1) is a text field containing '192.168.11.77'.  
 - 'Folder Hierarchy' (2) is an empty text field.  
 - 'User' (3) is a text field containing 'anonymous'.  
 - 'Password' (4) is a text field with masked characters '\*\*\*\*\*'.  
 - 'Interval' (5) is a dropdown menu set to '1 day'.  
 - 'Condition to Obtain' (6) is a dropdown menu set to 'Increment'.  
 In the 'Saving Setting' section:  
 - 'Saving Folder' (7) is a text field containing 'C:\Users\En-user\Documents\FTP'.  
 - 'Saving Condition' (8) is a dropdown menu set to 'Overwrite'.  
 - 'Suffix' (9) is a dropdown menu set to 'Sequential Number'.  
 At the bottom of the dialog are two buttons: 'OK' (10) and 'Cancel' (11).

Num.	Name	Descriptions
(1)	IP address	Specify IP address of FTP server device (KR). Initial value: 192.168.254.254
(2)	Folder hierarchy	Specify output destination folder for device data file. *1. If this is not specified, the file is going to be in root folder (directly under the external memory) of FTP server (KR). *2. If there is hierarch, specify as [Data¥Group].
(3)	User	Specify FTP server user name. Initial value: anonymous
(4)	Password	Specify FTP server password. Initial value: blank
(5)	Interval	Select and specify device data auto collection interval from 10min./ 30min./ 1h./ 4h./ 8h./ 12h. /1 day Initial value: 1 day
(6)	Condition to obtain	Select and specify acquisition condition of device data auto collection from All/ Increment. Initial value: Increment
(7)	Saving folder	Specify the folder path to save the data file collected. Initial value: C:¥Users¥En-user¥Documents¥FTP



Num.	Name	Descriptions
(8)	Saving condition	Select condition of data file saving from Overwrite/ suffix. Initial value: Overwrite If suffix is selected, character string specified at (9) is added to the end of the file name and saved in a file.
(9)	Suffix	Select one from Sequential number / yy/MM/dd/hh/mm / yy/MM/dd/hh / yy/MM/dd / yy/MM at saving if condition is set to suffix. Initial value: Sequential number
(10)	OK	Reflect edited contents.
(11)	Cancel	Cancel edited contents.

# 10-1 Device data file auto collection setting

(e.g.) Connect to KR, data under DATA\GROUP4 folder of CF card inserted to KR is automatically copied under C:\Chinotest folder in every 10min.

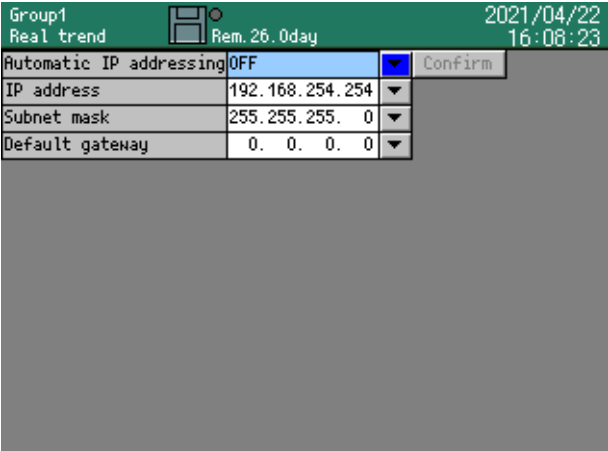
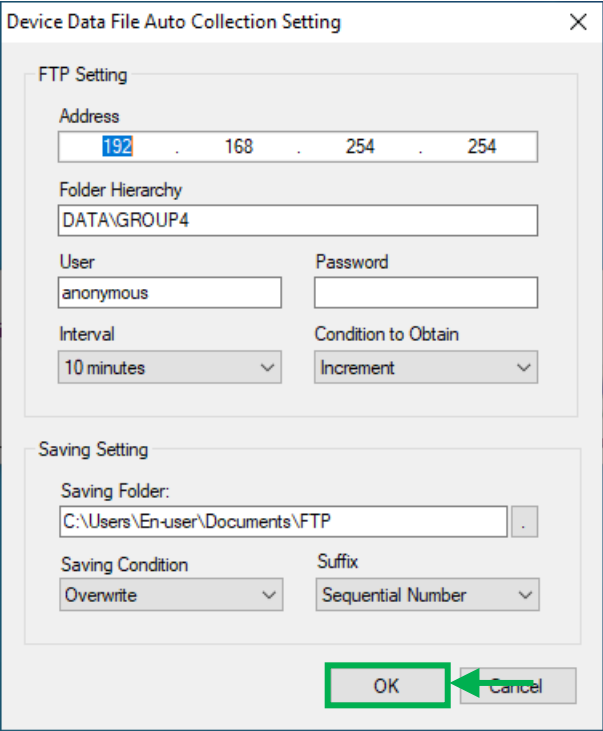
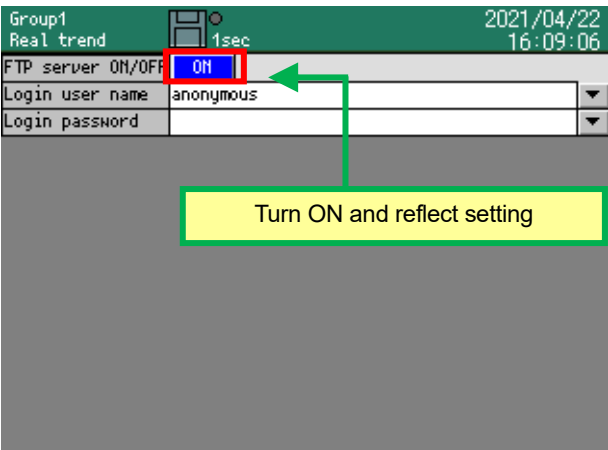
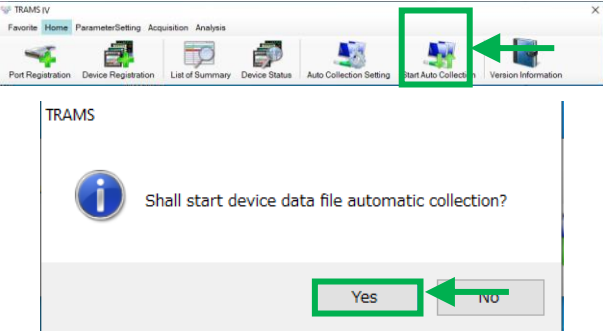
KR setting	TRAMS setting
<p>1. Insert external media (in here, it is CF card) to KR.</p> <p>2. Network setting → Ethernet setting</p>  <p>IP address: 192.168.254.254 (e.g.)</p>	<p>4. Home → Device data file auto collection setting</p>  <p>FTP setting area: correspond to setting of KR. Saving setting area: set saving destination in PC When setting is done, click [OK].</p>
<p>3. Network setting → FTP server setting</p>  <p>Turn ON and reflect setting</p>	<p>5. Home → Device data file auto collection start</p> 

6. If it is successfully connected to server, there is nothing specific is displayed.  
 Check that data is copied to appointed folder.

Type	Date/Time	Category	Group Name	Contents
i	4/22/2021 4:14:44 PM	Instrument data file auto acquisition		Succeeded : Start
i	4/22/2021 4:14:39 PM	Instrument data file auto acquisition		Succeeded : Stop
i	4/22/2021 4:14:08 PM	Instrument data file auto acquisition		Succeeded : Start
i	4/22/2021 4:07:47 PM	Application		Succeed : Startup
i	4/20/2021 11:56:22 AM	Application		Succeeded : End

FTP

This PC > Documents > FTP

Name	Date modified	Type	Size
Group4_G4(210422161508-210422161940)...	4/22/2021 4:19 PM	CSV File	13 KB
Group4_G4(210422162031-210422162033)...	4/22/2021 4:19 PM	CSV File	1 KB

If collection succeeds data is copied to appointed folder.

## 10-2 Device data file auto collection error

### 10-2-1 [Unable to connect to the remote server]

If address of FTP setting and set address of actual device (KR series) differs, then start auto collection, [Unable to connect to the remote server] is displayed on the summary.

In this case, set correct address.

Device Data File Auto Collection Setting

FTP Setting

Address: 192 . 168 . 254 . 30

Folder Hierarchy: DATA\GROUP4

User: anonymous Password: [empty]

Interval: 10 minutes Condition to Obtain: Increment

Saving Setting

Saving Folder: C:\Users\En-user\Documents\FTP

Saving Condition: Overwrite Suffix: Sequential Number

OK Cancel

In the case that FTP setting address is wrong

List of Summary

Export Search Setting Delete Print

[Unable to connect to the remote server] is displayed

Type	Date/Time	Category	Group Name	Contents
!	4/22/2021 4:37:22 PM	Instrument data file auto acquisition		Activation : [Unable to connect to the remote server]
i	4/22/2021 4:37:01 PM	Instrument data file auto acquisition		Succeeded : Start
i	4/22/2021 4:20:13 PM	Instrument data file auto acquisition		Succeeded : Stop
i	4/22/2021 4:19:03 PM	Instrument data file auto acquisition		Succeeded : Start
i	4/22/2021 4:19:01 PM	Instrument data file auto acquisition		Succeeded : Stop
i	4/22/2021 4:18:28 PM	Instrument data file auto acquisition		Succeeded : Start

## 10-2-2 [Unable to access FTP directory.]

Address of FTP setting and set address of actual device (KR series) matches, for some reasons, if it can not access to FTP directory, [Unable to access FTP directory.] is displayed on the summary.

The cause in this case may be...

- External memory is not inserted to KR
- It is accessing to FTP server through web browser
- There is some error in network setting

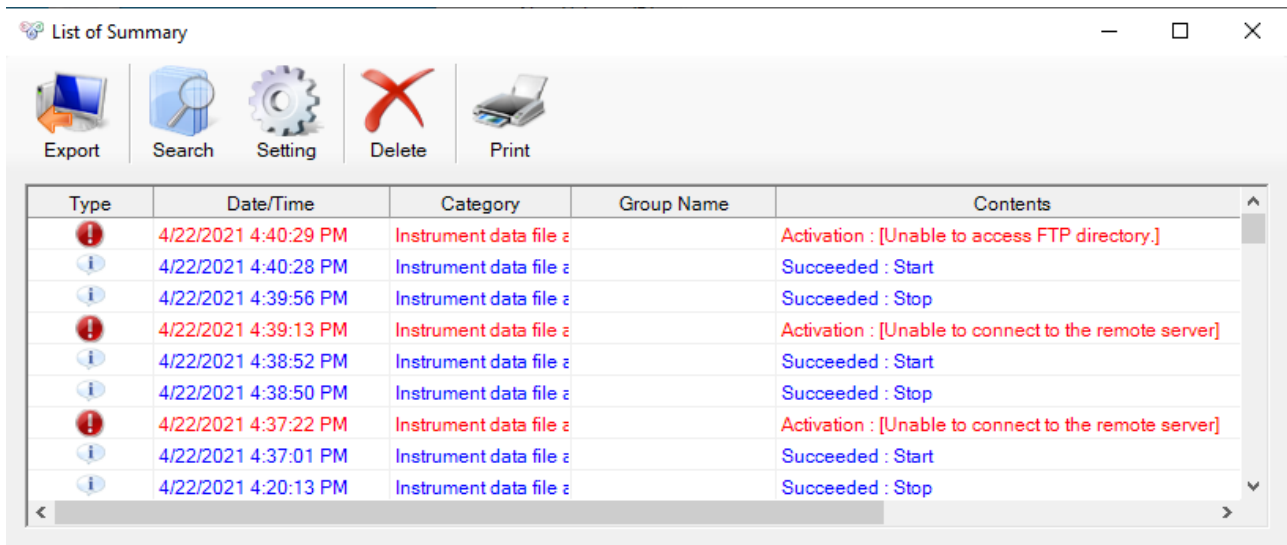

Type	Date/Time	Category	Group Name	Contents
!	4/22/2021 4:40:29 PM	Instrument data file z		Activation : [Unable to access FTP directory.]
i	4/22/2021 4:40:28 PM	Instrument data file z		Succeeded : Start
i	4/22/2021 4:39:56 PM	Instrument data file z		Succeeded : Stop
!	4/22/2021 4:39:13 PM	Instrument data file z		Activation : [Unable to connect to the remote server]
i	4/22/2021 4:38:52 PM	Instrument data file z		Succeeded : Start
i	4/22/2021 4:38:50 PM	Instrument data file z		Succeeded : Stop
!	4/22/2021 4:37:22 PM	Instrument data file z		Activation : [Unable to connect to the remote server]
i	4/22/2021 4:37:01 PM	Instrument data file z		Succeeded : Start
i	4/22/2021 4:20:13 PM	Instrument data file z		Succeeded : Stop

# 11 Version information display

Displays version information of TRAMS and holding device DLL.

### <Names of Parts on version information window>

The window is displayed by following operation.

[TRAMS]→[Home]→[Version information]

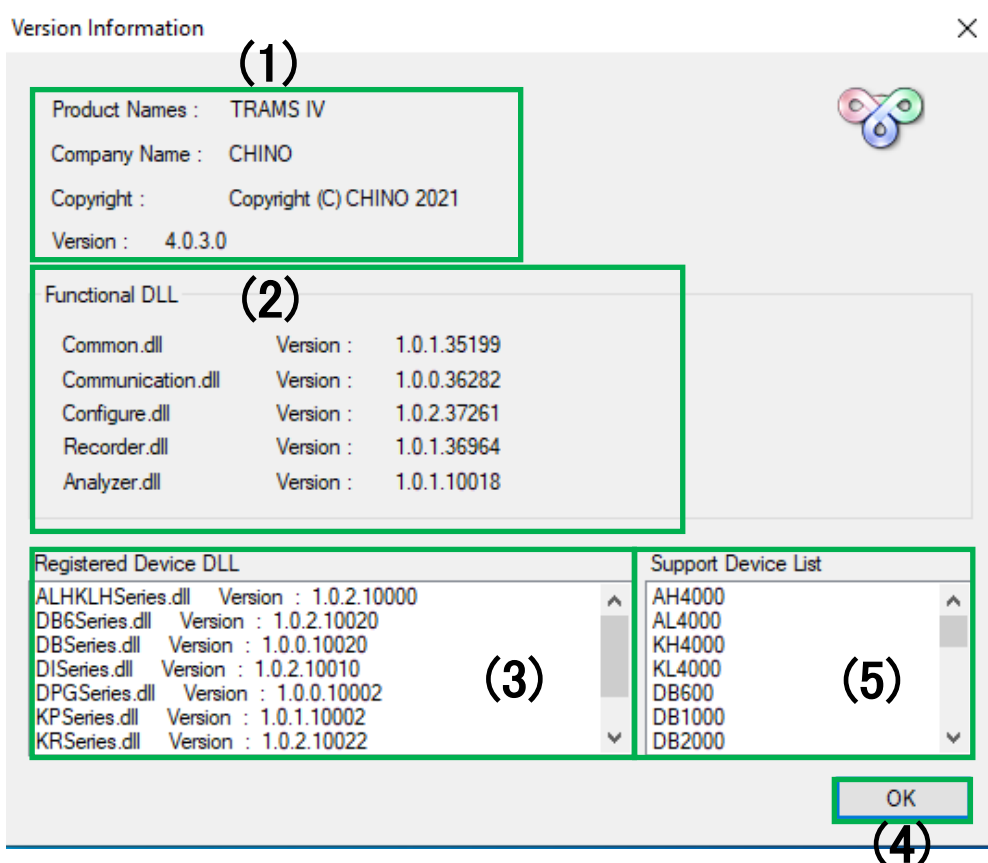

Num.	Name	Descriptions
(1)	TRAMS basic information	Displays TRAMS main EXE version information.
(2)	Functional DLL	Displays DLL version information used in TRAMS.
(3)	Registered Device DLL	Displays DLL version information of connected device. *Information changes depending on extension of registered DLL.
(4)	Support Device List	Displays the list of devices supported by this version of TRAMS. If (No setting function) is written, it support only acquisition and analysis.
(5)	OK	Close version information window.

# 12 Parameter setting

Sets parameters for registered device and output device parameter file.

## <Names of Parts on launcher parameter setting>

The window is displayed by following operation.

[TRAMS]→[Parameter setting]

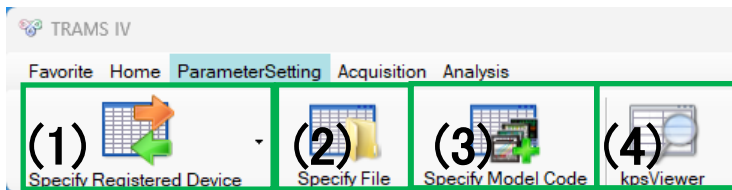

Num.	Name	Descriptions	Reference
(1)	Specify Registered Device	<ul style="list-style-type: none"> <li>· Loads parameter setting from registered device and displays.</li> <li><b>(Online)</b></li> <li>· List of registered devices is displayed from drop-down box. Click a device intended to set from the list.</li> </ul> <p>*Contents of setting items varies depending on a device.</p>	12-1-1 12-1-2
(2)	Specify File	<ul style="list-style-type: none"> <li>· Loads saved parameter setting file (*.pasconf, *.pkp, *.krs, *.a4s, *.ds1/ 2/ 3, *.dp1/ 2/ 3) and displays.</li> <li>*Contents of setting items varies depending on the specified device.</li> </ul>	12-2-1 (1)
(3)	Specify Model Code	<ul style="list-style-type: none"> <li>· From device selection window, displays parameter setting window and create new file.</li> <li>*Contents of setting items varies depending on the specified device.</li> <li>*Device selection wizard is same as 7-2. Device registration wizard window.</li> </ul>	12-2-1 (2)
(4)	Kps Viewer	Opens parameter setting file created by KR Heat Treatment Assistance Spec.	12-6

**Reference** For parameter setting  
To set parameter file created and saved by (2) Specify File or (3) Specify Model Code, it is necessary to write parameter to the device from (1) Specify Registered Device.

**Reference** For parameter reading (loading) and writing while data acquisition  
If parameter reading or writing is done while data acquisition, data acquisition communication stops. So, stop data memory operation and perform parameter writing.

## 12-1 Parameter setting window (specify registered device)

Set parameter to a registered device. At starting up the window, it loads set value from device. When the loading is successful, current parameter is displayed on the window.

### <Names of Parts on parameter setting window>

The window is displayed by following operation.

[TRAMS]→[Parameter setting]→[specify registered device]→[Select specific device from drop-down menu]

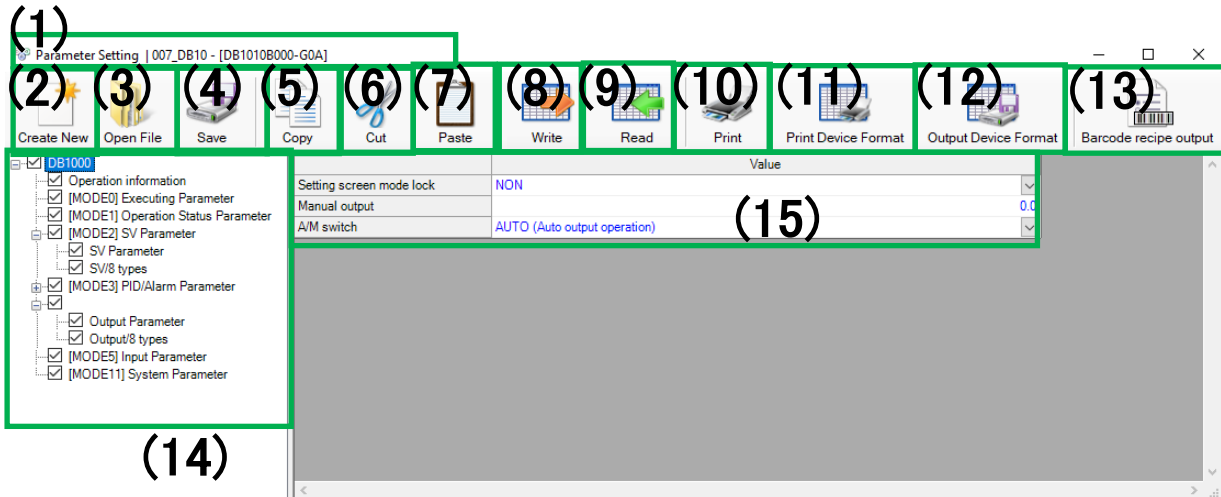

Num.	Name	Descriptions	Reference
(1)	Registered device information	Displays display name and model code of registered device.	
(2)	New	Opens up new setting file on the window. *Setting contents on the window is initialized, so if it necessary, perform (4) Save.	
(3)	Open file	Opens device parameter setting file (*.pasconf, *.pkp, *.krs, *.a4s, *.ds1/2/3, *.dp1/2/3). *If setting file of different model code (same device model) is loaded, message confirming whether or not to rewrite model code of registered device is displayed. To rewrite, select [Yes], to leave it as is, select [No]. (Only if [Yes] is selected, setting file is loaded.) *If rewriting device model code while in registration, registration information (model code only) of 7. Device registration window is changed. So be noted for next connection.	
(4)	Save	Specifies the file name and saves current setting contents as device parameter setting file (*.pasconf). If clicking Save button after opening setting file of KR series (*.krs), it can be saved as KRS. (Saving as KRS format is a function on and after TRAMSIII version 3.0.0.4) If clicking Save button after opening setting file of AL4000/AH4000 (*.a4s), it can be saved as A4S. (Saving as A4S format is a function on and after TRAMSIV version 4.0.0.0)	
(5)	Copy	Copies cell information of selected range of (15) setting value input area *Short cut is available as Ctrl + C keys.	



Num.	Name	Descriptions	Reference
(6)	Cut	Cut selected range of cell information of (15) setting value input area. Cell after cut becomes initial value. (The value same as when opening (2) New setting file) *Short cut is available as Ctrl + X keys	
(7)	Paste	Paste cell information obtained by (5) Copy or (6) Cut to cell after selected one. *Paste is not available if data type of the cells varies. *Short cut is available as Ctrl + V keys	
(8)	Write	Writes set value of checked item on (14) setting value category list to the device.	12-1-1
(9)	Read	Loads set value of checked item on (14) setting value category list from the device.	12-1-1
(10)	Print	Printouts set value of checked item on (14) setting value category list.	
(11)	Print Device Format	Printouts a list of setting information of specific device model.	12-3
(12)	Output Device Format	Outputs a list of setting information of specific device model as CSV.	12-3
(13)	Barcode recipe output	Outputs barcode recipe of KR2S/ 2D/ 3S/ 3D. This is only effective for DB600, DB1000 and DB2000.	12-4
(14)	Setting value category list	Displays set value category of subjected device as tree view. Each item has check box and if it is marked, it is included to processing, and if it is not checked, it is excluded from processing. By selecting specific item, detail is displayed on (15) Setting value input area.	
(15)	Setting value input area	Displays details of item selecting at (14) Setting value category list. Performs parameter setting by writing value input or changed here using (8) Export. *setting available value may change model code of a device or related neighboring set value.	

If NAK is displayed at parameter writing

(1) For KR2000, KR3000, KR2S, KR3S and KR3D, if setting screen is opened in actual device, it can not accept parameter writing from TRAMS. To write parameter from TRAMS, set the device to its operation screen.

Reference

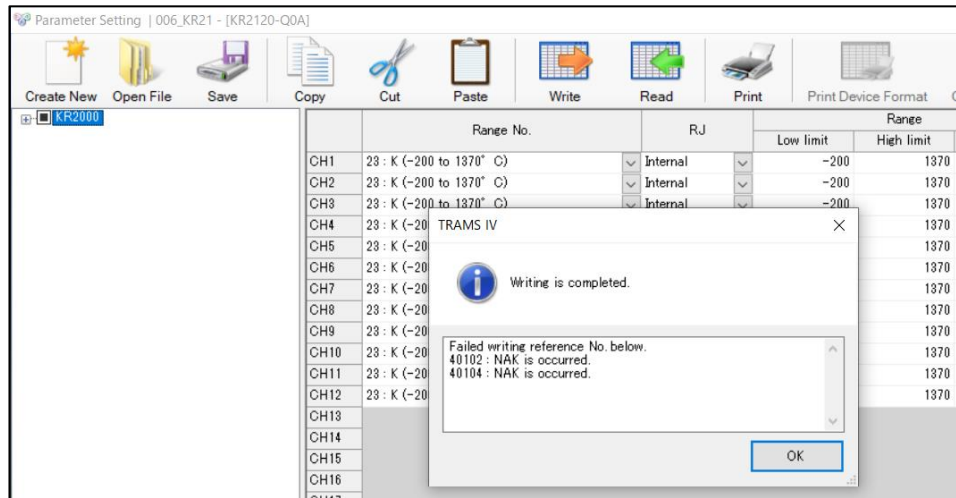

(2) If NAK is displayed in situation other than above:

Availability of each parameter setting is checked beforehand, but depending on the device specification, it does not accept parameter writing. Check reference number on communication interface manual of the device, and consider setting again. Problem may be solved by writing setting at once, but to write them individually.

### 12-1-1 Device parameter loading and writing

It describes operation of parameter setting load/ write from communicating with device in a flow from the startup of parameter setting window.

#### <Parameter setting window operation flow>

Parameter Setting | 007\_DB10 - [DB1020BS0B-G0A]

At the window startup, it starts obtaining set value from a device subjected to connecting.  
\* If cancel is clicked, the initial value is displayed.

Successfully loaded

Parameter Setting | 007\_DB10 - [DB1020BS0B-G0A]

If loaded set value is opened, color of the letters changes blue→black.

	Value
Measurement range	K1
Unit	° C
RJ	INT (RJ function ON)
Digital filter	4.0
Sensor correction	0.00
PV decimal point	1
Measurement scope zero	-200.0
Measurement scope span	1370.0
Linear scale decimal point	1
Linear scale low limit value	-200.0
Linear scale high limit value	1370.0
SV decimal point for display	4

Change input type form K1→R1  
Color of the letters changes black→blue by changing the set value.

	Value
Measurement range	R1
Unit	° C
RJ	INT (RJ function ON)
Digital filter	4.0
Sensor correction	0.00
PV decimal point	1
Measurement scope zero	0.0
Measurement scope span	1760.0
Linear scale decimal point	1
Linear scale low limit value	0.0
Linear scale high limit value	1760.0
SV decimal point for display	4

To the writing operation

Parameter Setting | 001\_DB10 - [DB1020BS0B-G0A]

Click Write

Overwrite Parameter. OK?

Click Yes (Y)

Progress bar is displayed

[MODE5] Input Parameter Writing...

TRAMS IV

Writing is completed.

Message of completing writing is displayed. Click OK

OK

Parameter Setting | 001\_DB10 - [DB1020BS0B-G0A]

Input type R1 is set to connecting device  
Color of letters of which set value successfully wrote changes blue -> black

\*If changing or setting of input type (range number) is performed, parameter is loaded form device again. (To take consistency of measuring range higher/ lower limit, linear scale zero/ span etc.)

## 12-1-2 Device parameter file saving

It describes how to load parameter setting and saved in a file from communication to a device.

### <Parameter setting window operation flow>

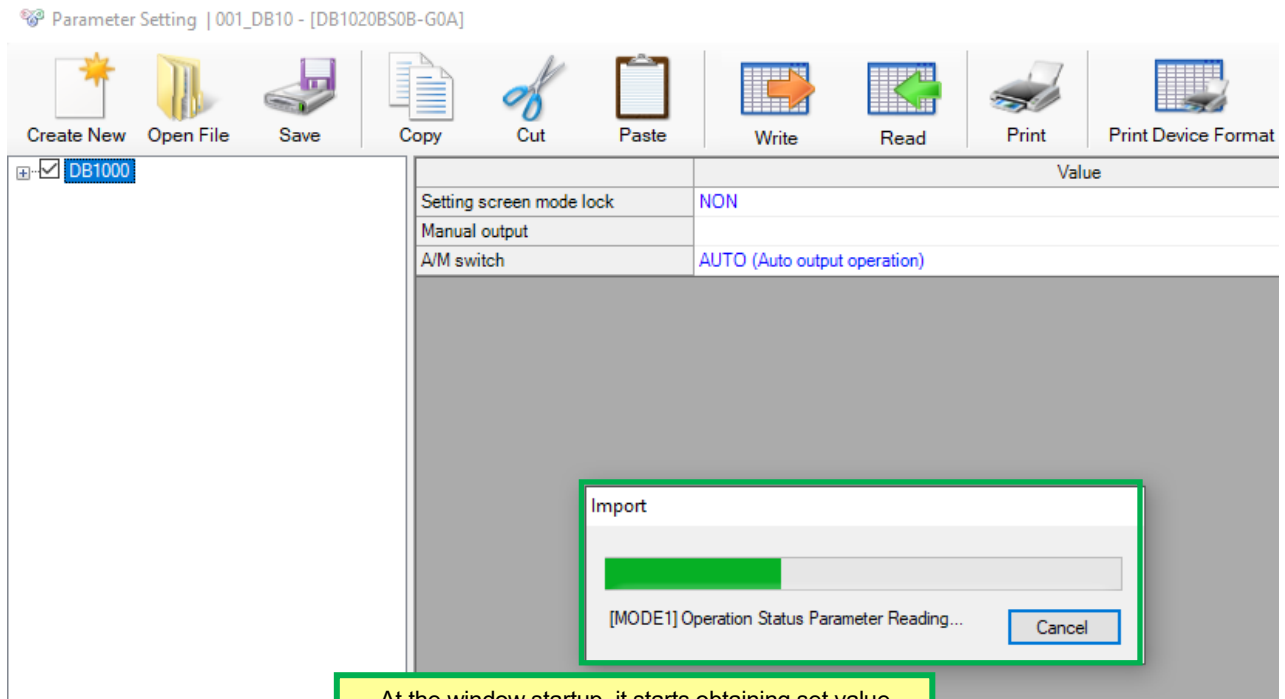

At the window startup, it starts obtaining set value from a device subjected to connecting.

\* If cancel is clicked, the initial value is displayed.

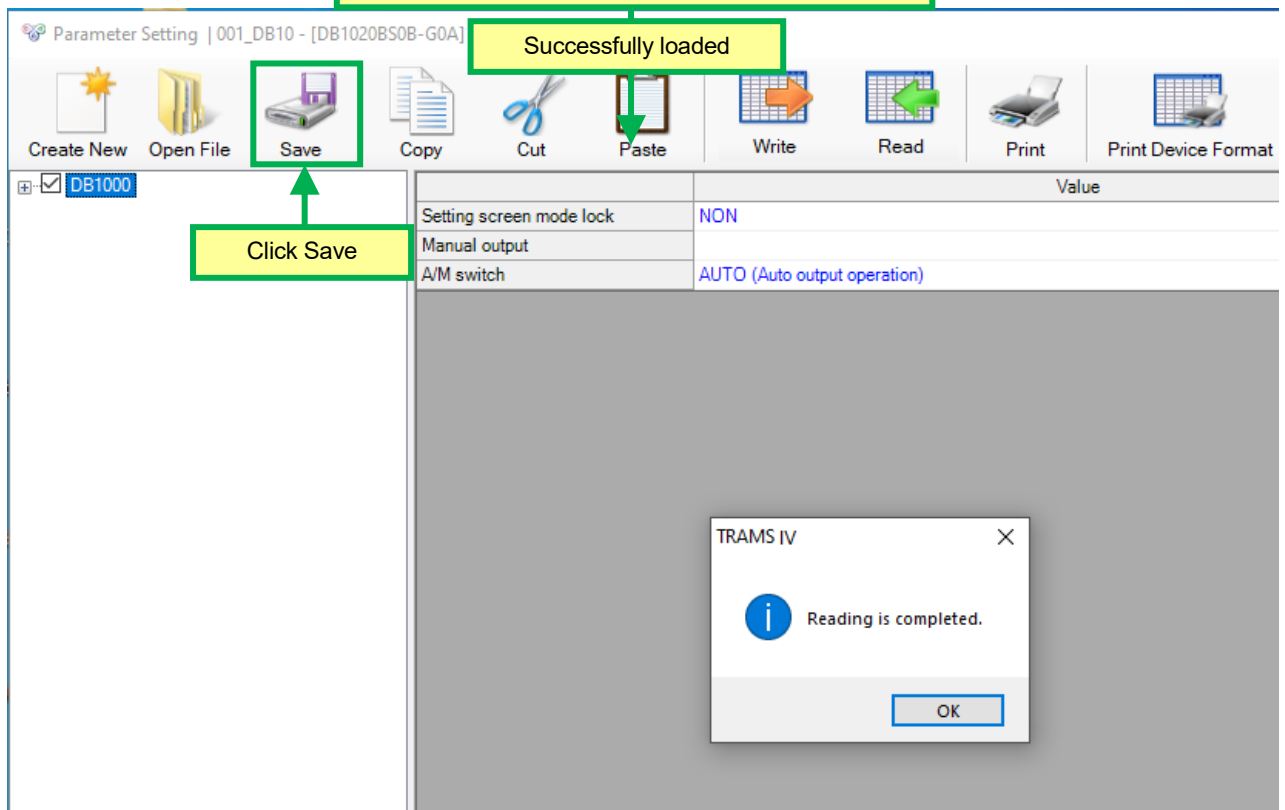

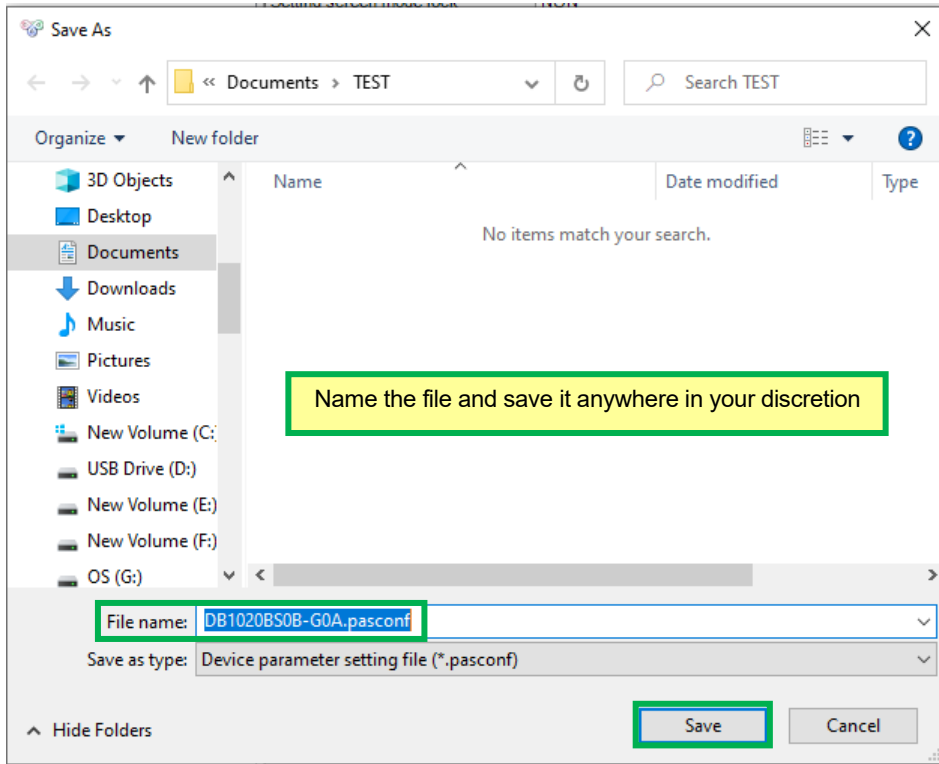

## 12-2 Parameter setting window (specify file / specify model code)

It does not communicate to the device at [Specify file] and [Specify model code], but edits parameter file. It does not load parameters from the device at startup. The files available to be loaded are \*.pasconf, \*pkp (only DB1000/ DB2000, KP1000/ KP2000/ KP3000), \*.krs, \*.a4s, \*.ds1/ 2/ 3, \*.dp1/ 2/ 3.

It can not reflect setting to the device from this window. To set parameter file created or saved to the device, refer to 12-2-1. Loading and writing device parameter file, (3) Case of loading saved device parameter file and writing to the device.

### <Parameter setting window view>

The window is displayed by following operation.

[TRAMS]→[Parameter setting]→[Specify file] (Parameter setting window)

Or

[TRAMS]→[Parameter setting]→select model or model code from [Specify model code] and displays parameter setting window.

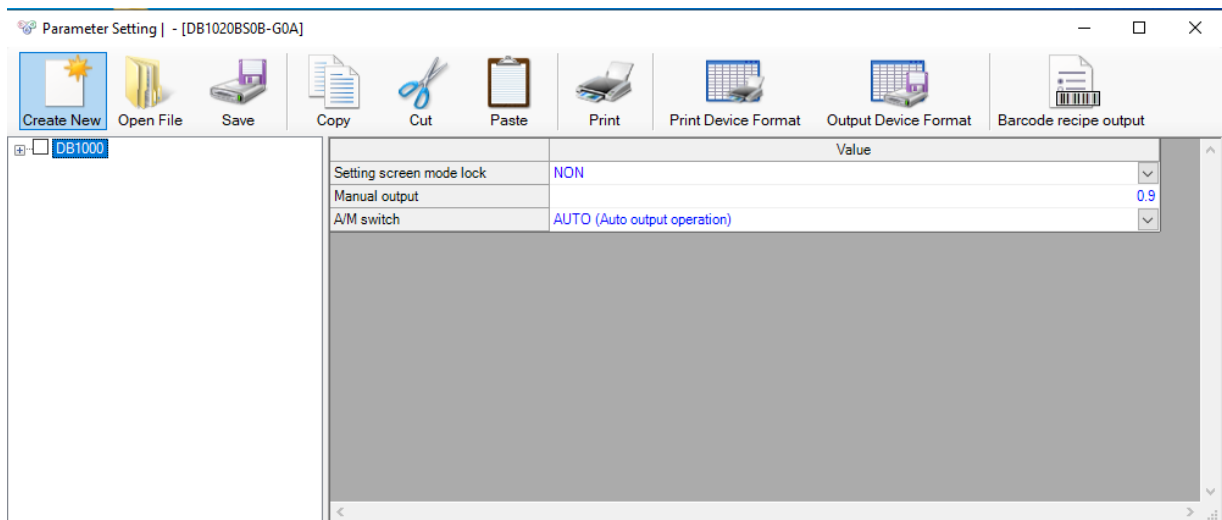

## 12-2-1 Loading and writing device parameter file

It describes operation flow of editing parameter loaded from a device or parameter file saved in TRAMS and writing set values.

### <Parameter setting window operation flow>

(1) Case of startup parameter setting window from device parameter file

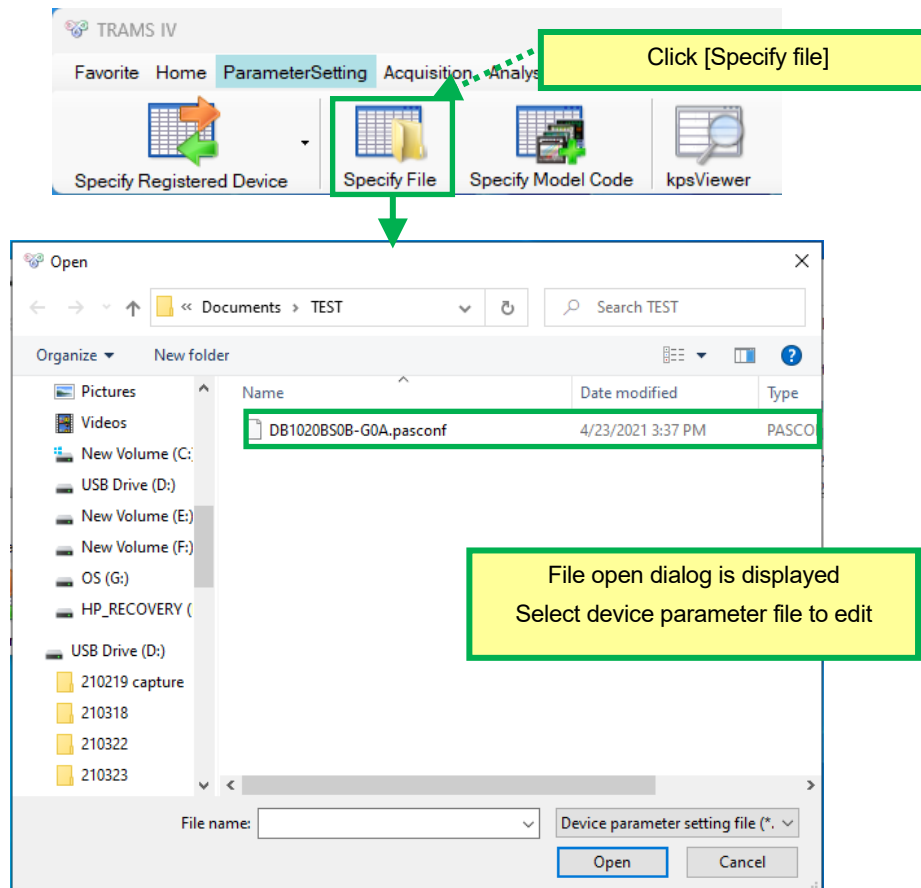

The parameter files available to be loaded are \*.pasconf, \*pkp (only DB1000/ DB2000, KP1000/ KP2000/ KP3000), \*.krs, \*.a4s, \*.ds1/ 2/ 3, \*.dp1/ 2/ 3. For loading \*pkp, a part of model code may not be obtained. In that case, a setting window by models is displayed. Select a model code and click Next.



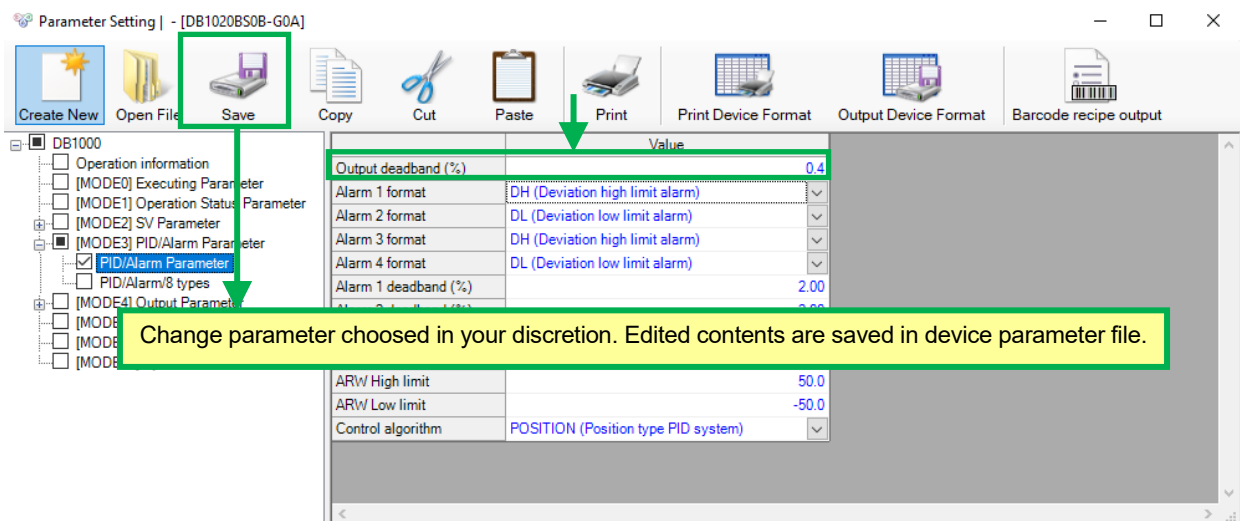
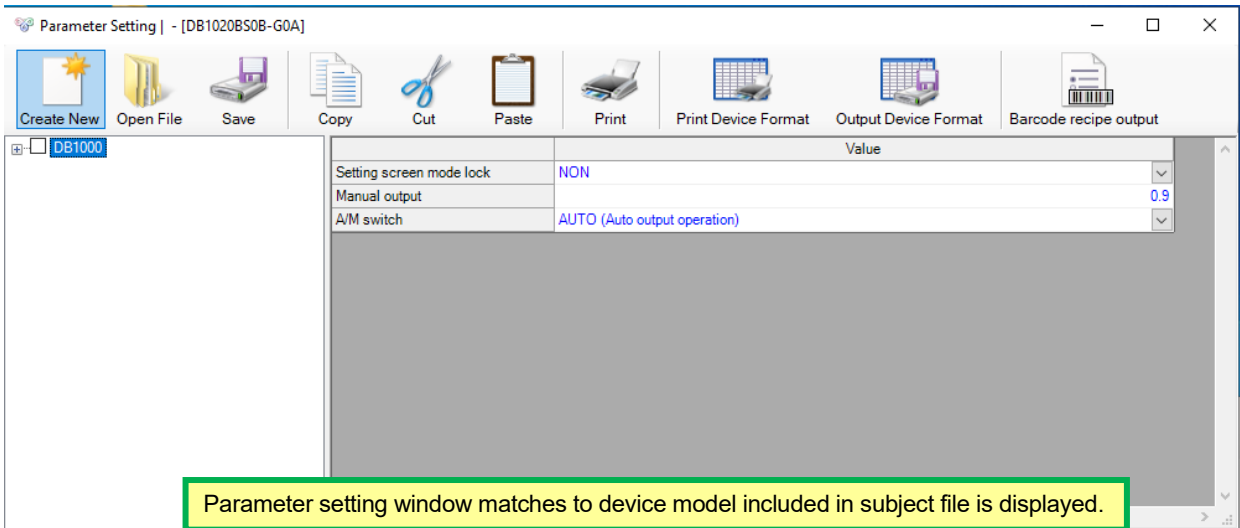
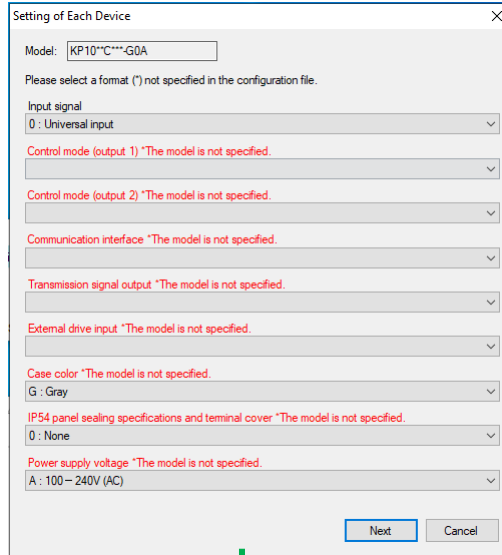

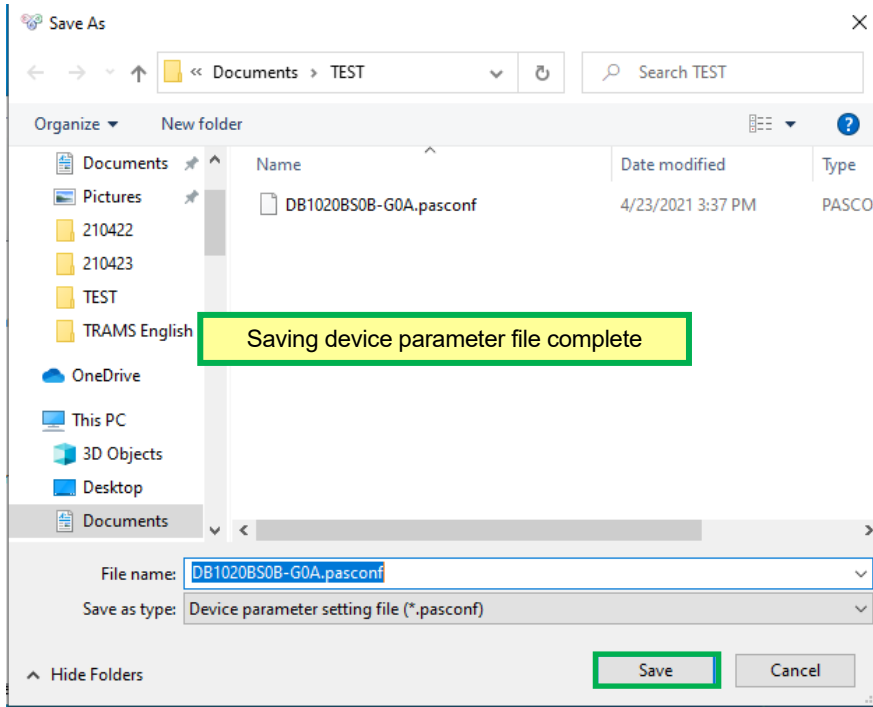

**Reference** For parameter file saving format  
 Saving parameter file as \*.pasconf format, (\*.krs) for KR series, or (\*.a4s) for AL4000 / AH4000. However, to save as KRS/ a4s format, it is only available by creating KRS or a4s file by device first, then saving it to CF card or SD card etc. and loading it by TRAMS.  
 (saving as KRS format is a function from TRAMS III version 3.0.0.4, as a4s format is from TRAMS IV)  
 For \*.pasconf format, device model information is saved in the file.

**Reference** For parameter setting by DP-G  
 For details, refer to 12-5.



**Caution**

**To save as KRS format or a4s format, reading source KRS file or a4s file is necessary.**

×

The loaded setting file cannot be found.  
To save in KRS format, use the loaded source setting file.

**Reference** To load \*pkp  
 To load \*pkp, a part of model code can not be obtained, so a setting window by models is displayed every time.  
 In that case, save parameter file (\*.pasconf format) and from next time on, it is unnecessary to input parameters in setting window of various model only by opening \*.pasconf file.

(2) Case of editing by startup parameter setting window from [Specify model code]

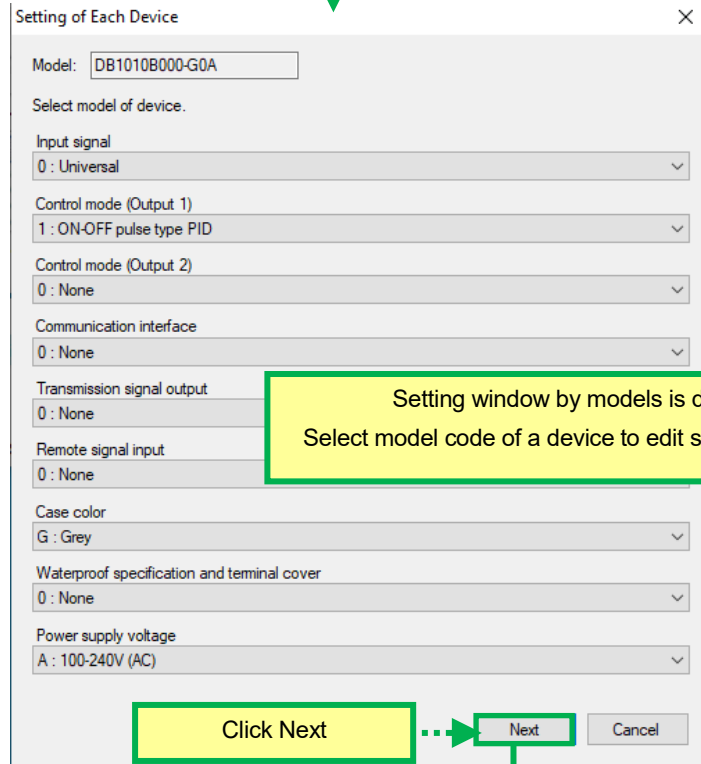
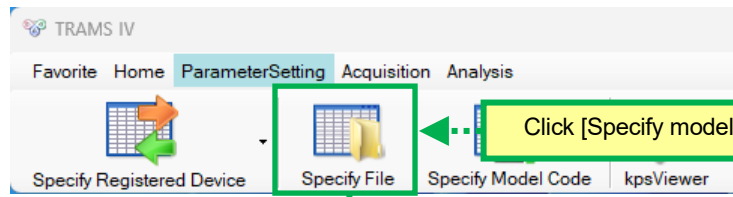

Setting window by models is displayed.  
Select model code of a device to edit setting information.

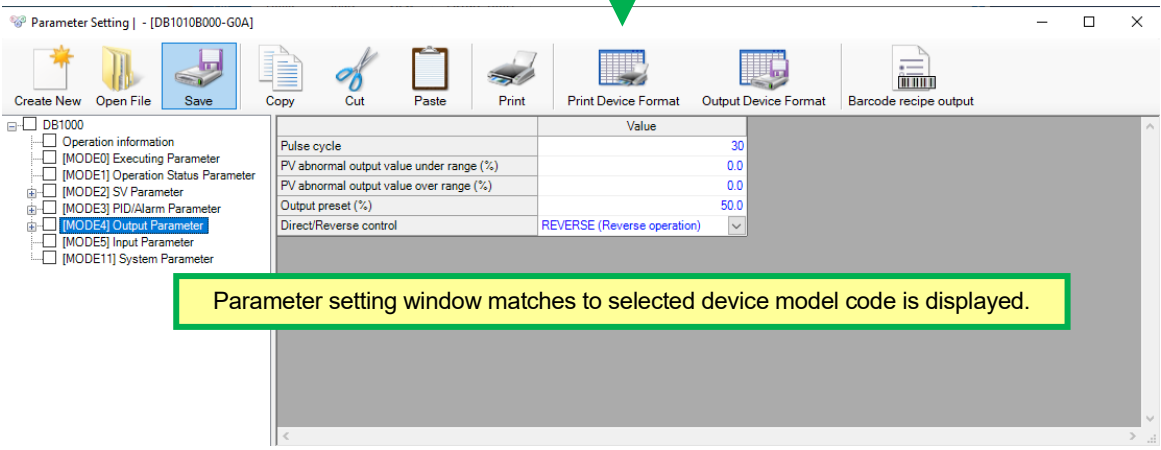
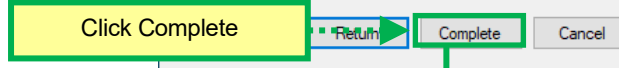
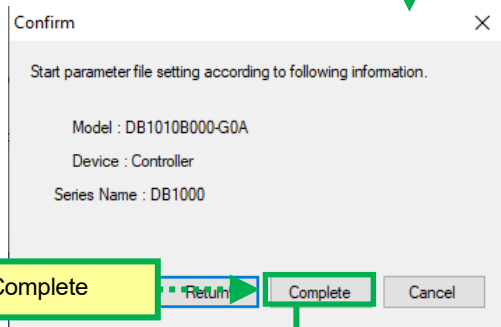
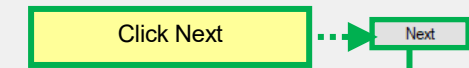

Parameter setting window matches to selected device model code is displayed.

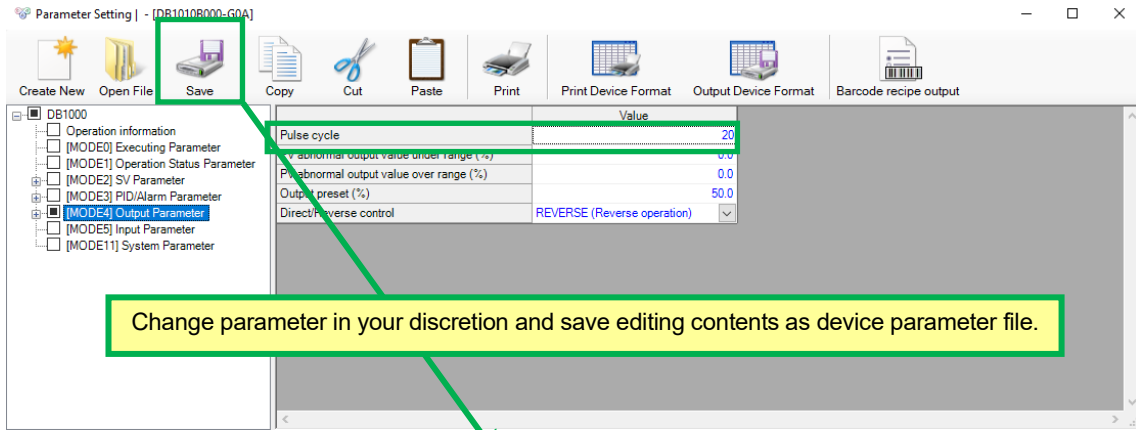

Change parameter in your discretion and save editing contents as device parameter file.

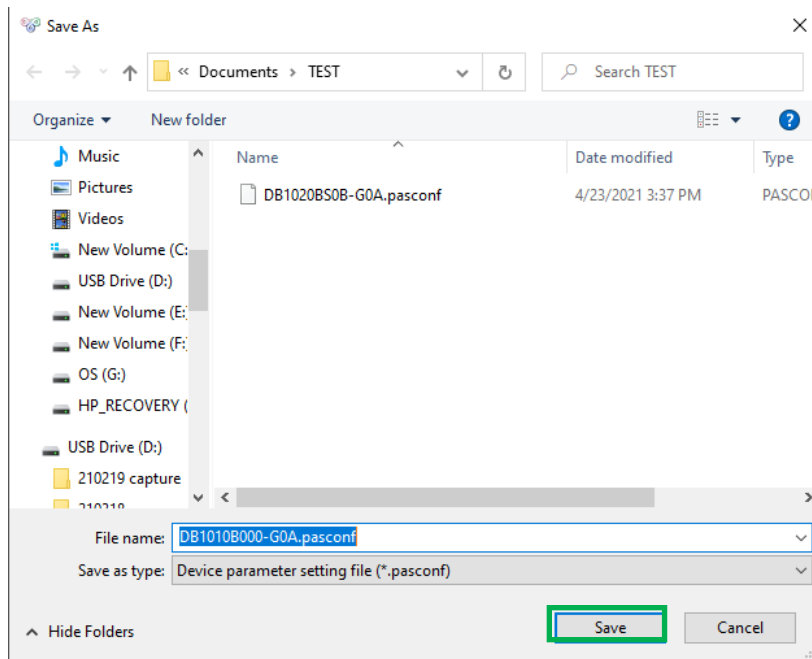

Saving device parameter file complete

(3) Case of loading saved device parameter file and writing to the device

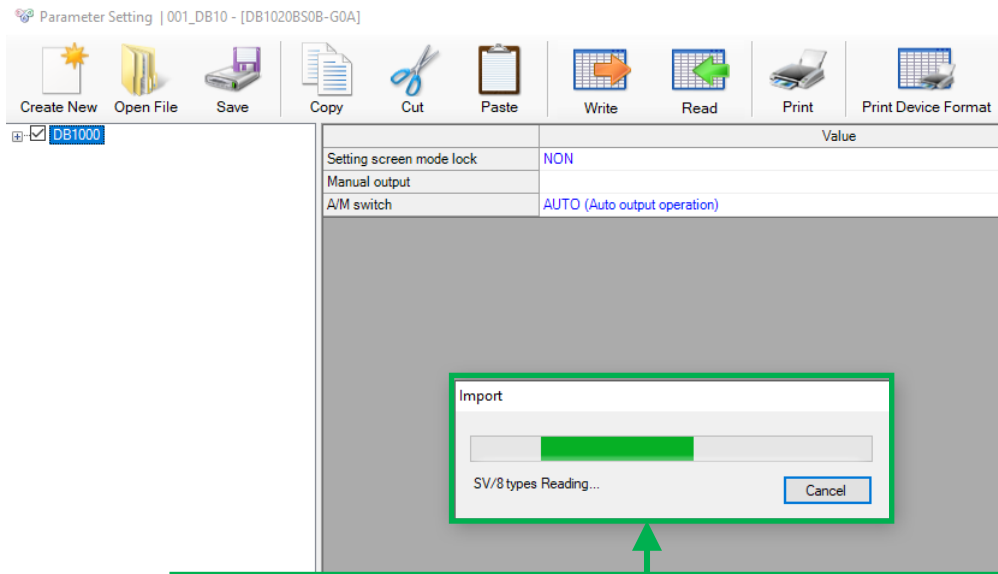
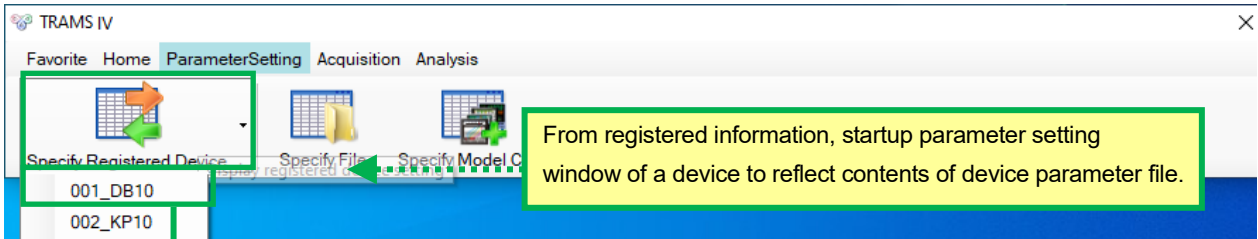

At the window startup, it starts obtaining set value from a device subjected to connecting.  
\*If cancel is clicked, the initial value is displayed.

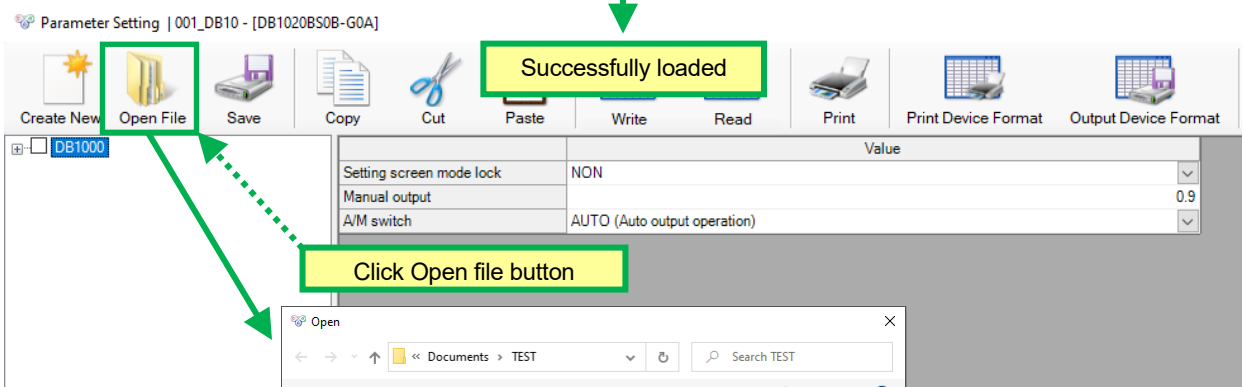

Click Open file button

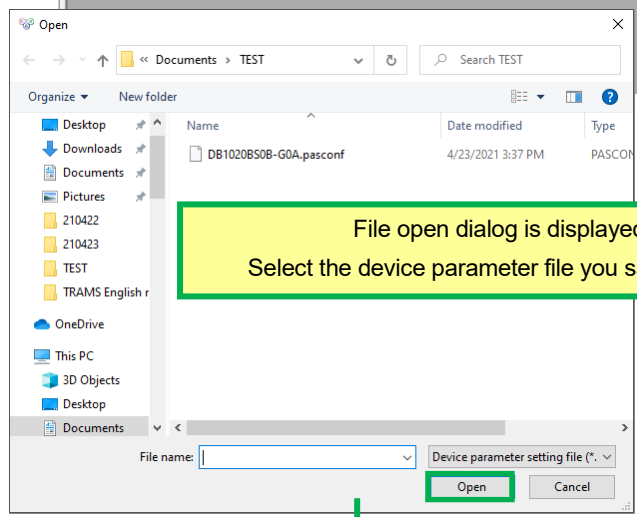

File open dialog is displayed.  
Select the device parameter file you saved earlier

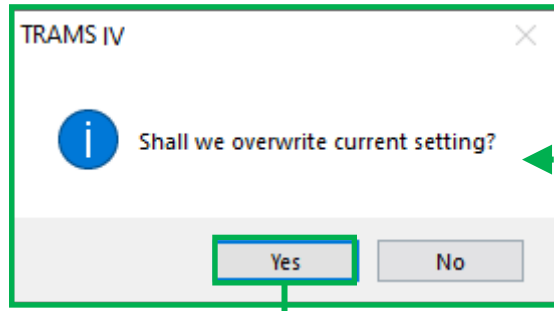

Current setting contents are discarded, and message stating overwriting is displayed. Click Yes (Y)

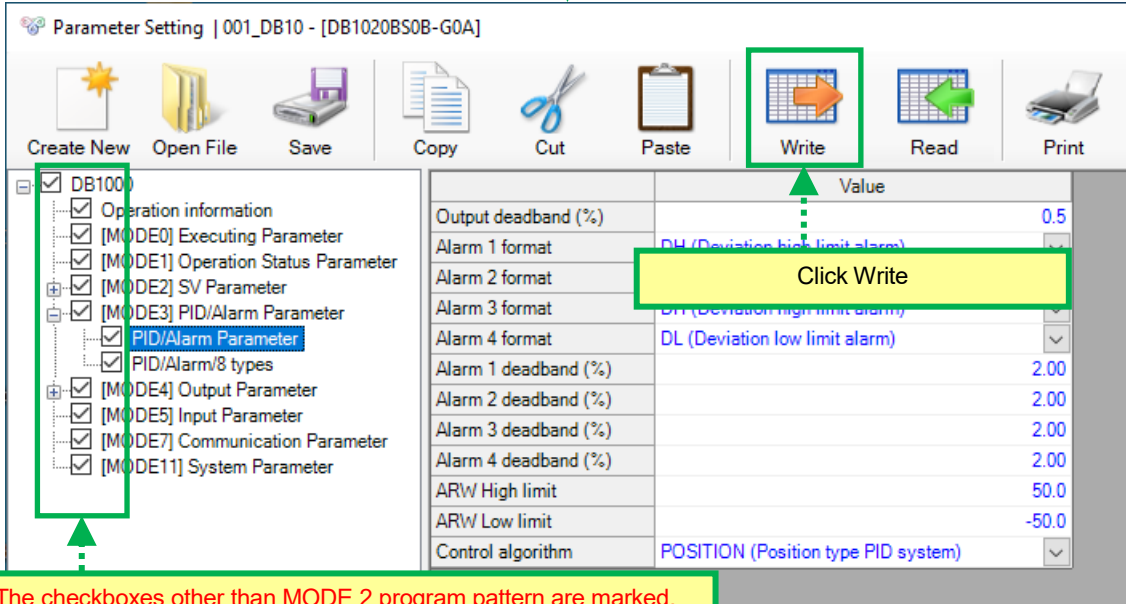

The checkboxes other than MODE 2 program pattern are marked. Check the other checkboxes as needed. If the MODE5 input parameters do not match on the actual device and the software screen, the parameters will be incorrect. Write the input parameters together.

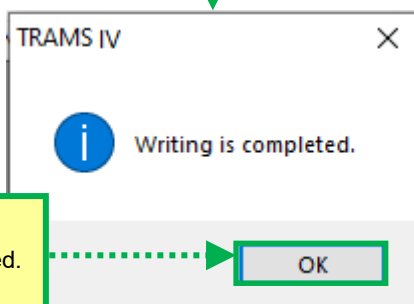
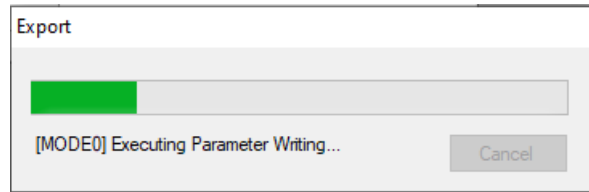

Message stating writing process complete is displayed. Click OK

Parameter Setting | 001\_DB10 - [DB1020BS0B-G0A]

Create New Open File Save Copy Cut Paste Write Read Print

	Value
Output deadband (%)	0.5
Alarm 1 format	DH (Deviation high limit alarm)
Alarm 2 format	DL (Deviation low limit alarm)
Alarm 3 format	DH (Deviation high limit alarm)
Alarm 4 format	DL (Deviation low limit alarm)
Alarm 1 deadband (%)	2.00
[MODE4] Output Parameter	2.00
[MODE5] Input Parameter	2.00
[MODE7] Communication Parameter	2.00
[MODE11] System Parameter	50.0
	-50.0
Control algorithm	POSITION (Position type PID system)

Set value of device parameter file is set to connecting device.  
Color of the letters of the set value which was successfully written changes from blue → black.

Device parameter writing complete

Reference

If message of [Present instrument model and model of reading target file are different.] is displayed  
 After connecting to registered device when parameter file is opened, [Present instrument model and model of reading target file are different. Update registered instrument model to a model of reading target file?] message may be displayed. If [Yes] is selected, registered device information is updated.  
 After opening file, if it is to be communicating with the device, check that the device and registered device information matches.

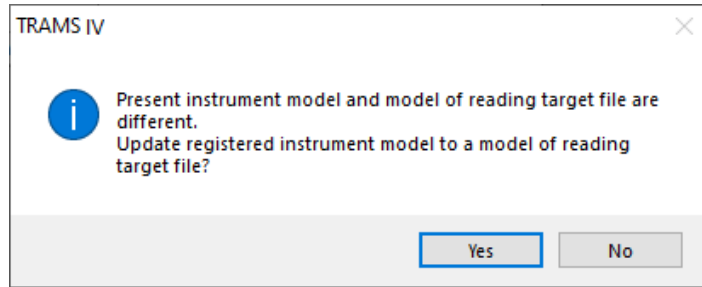

Reference

If error message [Fail to write.] is displayed at parameter writing  
 If it stating “Model codes of registered device and connecting device do not match, and failed writing.”, check registered device information on top of the parameter setting window. If it is different from the device, revise registered device information manually.  
 (1) Compare registered device information and actual device.  
 (2) From Home, select a device from device registration and click Wizard registration button.  
 (3) Match the model code to the actual device’s and click Next button. On confirmation window, click [Complete] button.  
 (4) Check if it matches to the model code of the device, click OK button, and open parameter window again from parameter setting →. [Specify registered device]

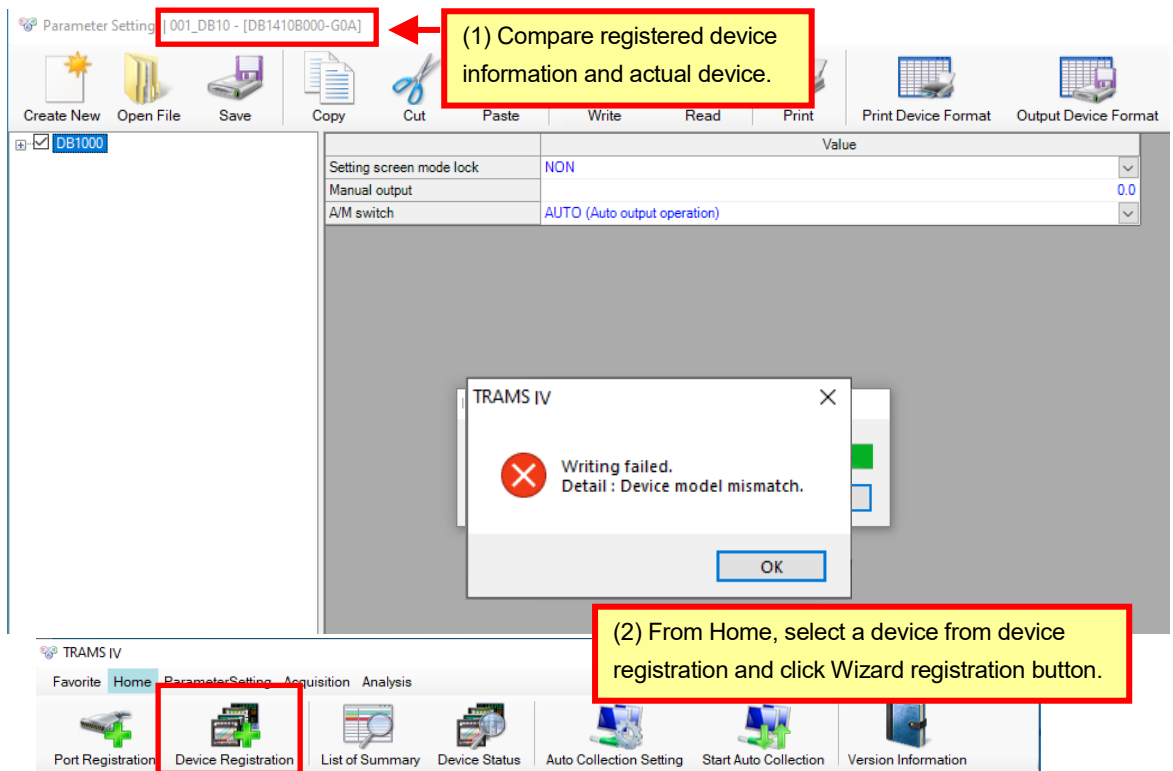



Device Registration

Enter Model Code Wizard Registration

(3) Match the model code to the actual device's and click Next button. On confirmation window, click [Complete]

No.	Model	Device Name	Port	Address	Retry Count	Timeout [ms]
1	DB1410B000-G0A	001_DB10	COM1	1	3	

Setting of Each Device

Model: DB1010B000-G0A

Select model of device.

Input signal  
0 : Universal

Control mode (Output 1)  
1 : ON-OFF pulse type PID

Control mode (Output 2)  
0 : None

Communication interface  
0 : None

Transmission signal output  
0 : None

Remote signal input  
0 : None

Case color  
G : Grey

Waterproof specification and terminal cover  
0 : None

Power supply voltage  
A : 100-240V (AC)

Next Cancel

Confirm

Start parameter file setting according to following information.

Model : DB1010B000-G0A  
Device : Controller  
Series Name : DB1000

Return Complete Cancel

Device Registration

Enter Model Code Wizard Registration Device Scan Information Setting Copy Cut Paste Delete

No.	Model	Device Name	Port	Address	Retry Count	Timeout [ms]	Command Interval [ms]	Delay between Devices[ms]	Update Interval [ms]
1	DB1010B000-G0A	001_DB10	COM1	1	3	2000	0	0	1000

(4) Check if it matches to the model code of the device, click OK button, and open parameter window again from parameter setting → [Specify registered device].

OK Cancel

## 12-3 Print Device Format / Output Device Format

### 12-3-1 Overview

Function to print out or file output controller's parameters by organized format. This function is only valid for controllers which support parameter setting. This function is not for recorder.



### 12-3-2 Print device format

At exclusive format printing, header and footer specification is available. (Function from TRAMSIV)

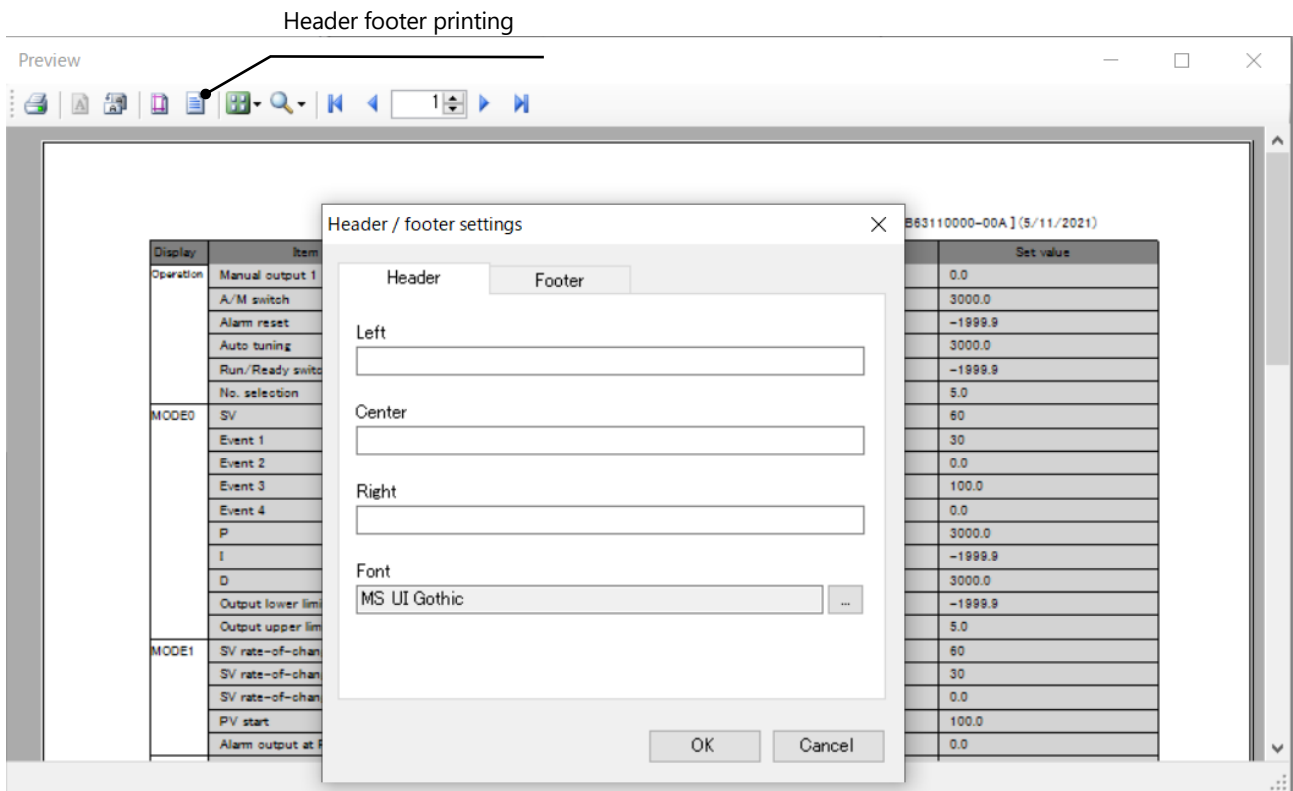

### 12-3-3 Output device format

Output as CSV file. (For DP-G, it outputs .xlsx file.)

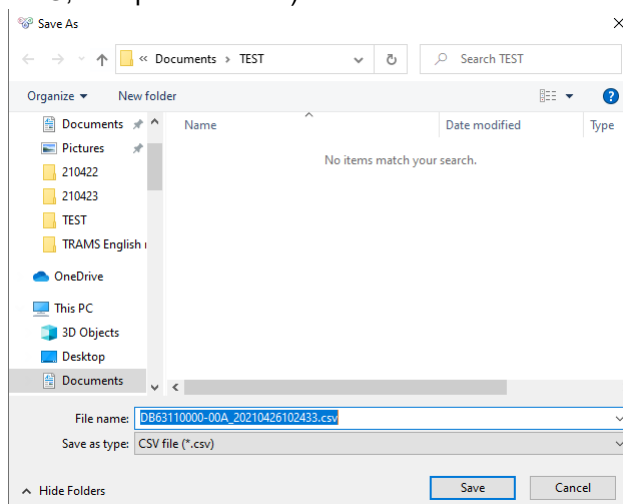

## 12-4 Barcode recipe output

### 12-4-1 Overview

KR2S, KR3S, KR2D and KR3D has function that send setting parameters to controllers connected as low order (optional function). By TRAMS's [Barcode recipe output] function, file for barcode display (.xlsx) and transmission command list file (.csv) can be made just one button.

(e.g.)

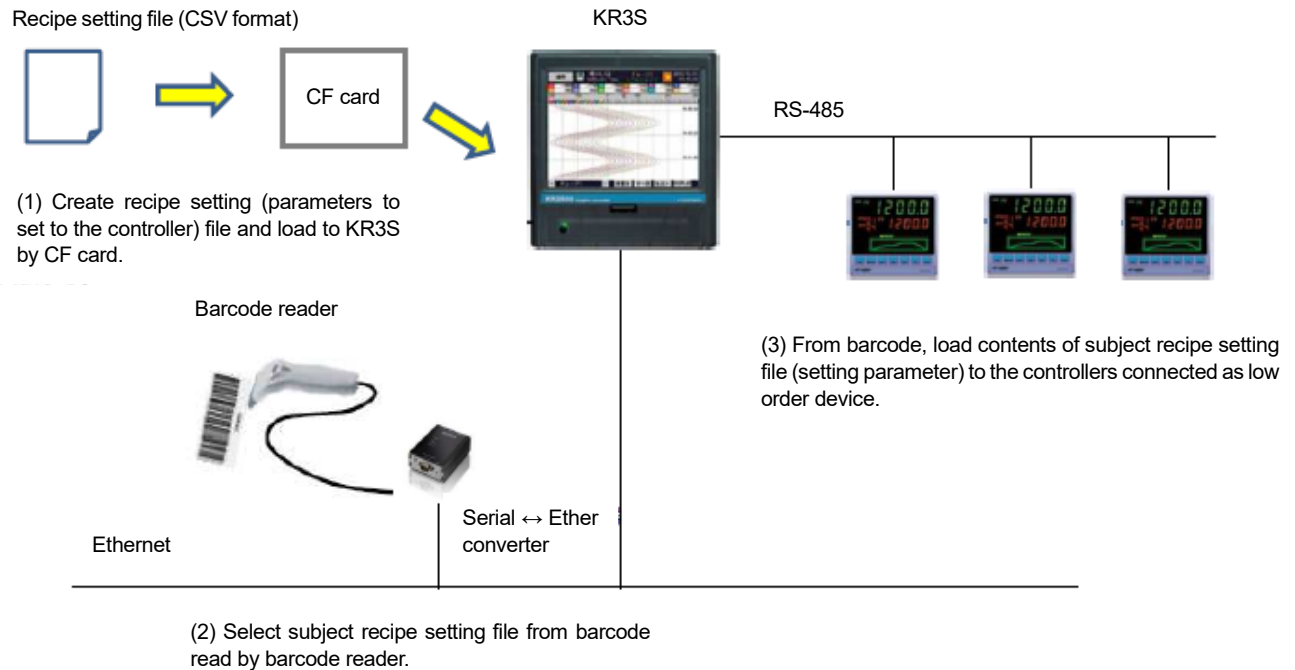

#### Reference

For barcode recipe function  
If contents of setting parameter to the controller have been decided beforehand, setting is made easy by barcode, so it reduces work of operator at factory etc.

### 12-4-2 Barcode recipe file

Recipe files to be able to output by TRAMS are as follow.

Subject device: DB600, DB1000, DB2000

Subject parameter: Output parameters in a table below. It does not output parameters not listed in the table.

## DB600

MODE	Item	Remark
MODE0	SV	Decimal point position depends on MODE5 linear scale decimal point.
	Event 1 to 4	Decimal point position depends on MODE4 event mode setting.
	P, I, D	
	Executing output limiter L / H	
MODE3	SV	8-type. Decimal point position depends on MODE5 linear scale decimal point.
	Event 1 to 4	8-type. Decimal point position depends on MODE4 event mode setting.
	P, I, D	8-type
	Output limiter L / H	8-type
Operation information	Run/ Ready switch	
	Execution No. selection for constant value operation	

## DB1000

MODE	Item	Remark
MODE0	SV	Decimal point position depends on MODE5 linear scale decimal point.
	P, I, D	
	Alarm value 1 to 4	Decimal point position depends on MODE5 linear scale decimal point.
MODE1	Select Execution number	
MODE2	SV	8-type. Decimal point position depends on MODE5 linear scale decimal point.
MODE3	PID	8-type
	Alarm value 1 to 4	8-type. Decimal point position depends on MODE5 linear scale decimal point.
MODE4	Output variation limiter Down	8-type. For specifications with external input for switching over the set value: display up to No. 9.
	Output variation limiter Up	8-type. For specifications with external input for switching over the set value: display up to No. 9.
	Output limiter L	8-type
	Output limiter H	8-type

## DB2000

MODE	Item	Remark
MODE0	SV	Decimal point position depends on MODE5 linear scale decimal point.
	P, I, D	
	Alarm value 1 to 4	Decimal point position depends on MODE5 linear scale decimal point.
MODE1	Run/ Ready switch	
	Select execution number	
MODE2	SV	8-type. Decimal point position depends on MODE5 linear scale decimal point.
	Remote shift	8-type. Decimal point position depends on MODE5 linear scale decimal point+1 (If linear scale decimal point is 4, 4 digits after the decimal point)
MODE3	PID	8-type
	Alarm value 1 to 4	8-type. Decimal point position depends on MODE5 linear scale decimal point.
	PID No.9	8-type
	SV section for automatic PID	No.1 to No.8
	AT2 ON/ OFF	8-type
	SV for AT2	8-type
	AT3 ON/ OFF	8-type
	SV for AT3	8-type
MODE4	Output preset	8-type
	Output variation limiter Down	9-type
	Output variation limiter Up	9-type
	Output limiter L	8-type
	Output limiter H	8-type

**12-4-3** Creating procedure

< Preparation > Prepare followings.

1. KR barcode recipe specification	Select KR2S/ 3S, KR2D/ 3D barcode recipe specification.
2. Controller	Controllers support parameter file output on TRAMS is DB600, DB1000 and DB2000.
3. Barcode reader	Barcode hand-held scanner [HC76TR] manufactured by DENSO Corporation
4. Serial/ Ethernet converter	N Port Express DE-311 manufactured by Moxa Inc. (1-port RS-232/ 422/ 485 serial device server)
5. Barcode font (Install to the PC)	Supporting barcode format is as follow. <ul style="list-style-type: none"> <li>·UPC-A/ UPC-E    ·EAN-13/ EAN-8/ EAN-128</li> <li>·Codabar (NW-7)    ·Code39/ Code128</li> </ul>

**Reference**

Refer to instruction manuals of barcode reader and serial/ Ethernet converter for their setting.

**<Procedure>**

**1. Open parameter setting window and input parameter.**

Click either of [Specify Registered Device], [Specify File] or [Specify Model Code] to open parameter setting window.  
Input parameters.

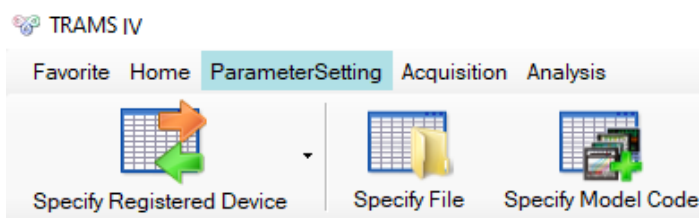

 <p><b>Caution</b></p>	<p><b>To set parameters on [Specify File] or [Specify Model Code], parameter loading from the device can not be done. If settings of barcode recipe file and the device are different, decimal point position of set value do not match.</b></p> <p><b>To avoid this, match setting of MODE5 input parameter to the device.</b></p> <p><b>For DB600, match MODE 4 event parameter as well.</b></p>
---	--

**2. Click barcode recipe output button.**

When parameter input is done, click [Save] button. Save parameter as pasconf format. (Save as a copy).

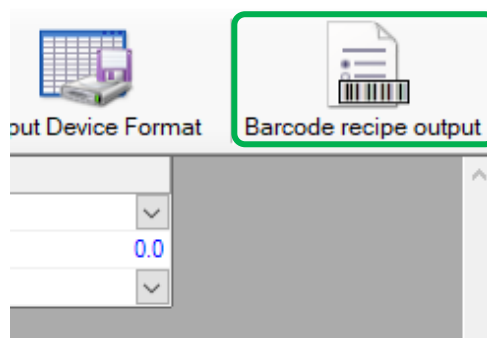

Click [Barcode recipe output] button to the right of parameter window.

For window of device other than subjective device, the icon is grayed out and clicking is disabled.

**3. Perform setting of output file first and click [Output] button.**

Check setting contents on [Barcode recipe output] window. Change them if necessary. By clicking [Output] button, file is output to specified directory respectively.

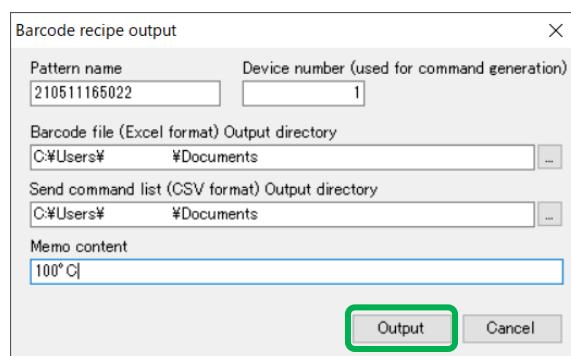

Pattern name	Up to 12 single-byte characters (half-width character) can be entered and changed. Character type to be recognized as barcode varies depending on the barcode type. Initial value: last two digits of year, month/ day/ hour/ minute/ second
Device number	Input device number (1 to 99) of low order controller. If parameter window is opened from [Specify Registered Device], transmission telegram is created referring to this number.
Barcode file output directory	Specify file output destination of xlsx file with pattern name and barcode written.

Transmission command list output directory	Specify file output destination of csv file with telegram written to send to low order controller. Connect CF card to the PC and under the CF card, create a recipe folder. This directory is output destination.
Memo	Memo can be written up to 30 letters. (optional)

#### 4. Check created barcode file.

TRAMS output contents as following illustration.

It output one barcode (pattern name written as barcode) for one controller.

Format of barcode file is at following place. This format or design can be changed, however, the cell of contents' output destination can not be changed.

C:\Program Files (x86)\CHINO\TRAMS\Template (for 64bit)

C:\Program Files\CHINO\TRAMS\Template (for 32bit)

Print out after checking and editing is done.

#### Reference

Barcode is not displayed, if barcode font is not installed.

Install barcode font to use in advance.

(Example above uses Code 39)

If the letter is not supported by the barcode, correct barcode can not be displayed. Check the barcode standard to be use.

#### Reference

Pattern name and barcode are output only to the top of the format.

Bottom 4 parts are left as blank. The blanks are used when multiple barcode files are created. Multiple barcodes can be displayed and managed on one sheet by creating multiple barcode files and copying and pasting according to the design.

## 5. Check created transmission command list file.

Open send command list file (.csv).

Transmission telegram to low order device is listed in column A. Item name of transmission telegram is listed in column B. At default, all the subject parameters are listed.

Check the contents and delete parameter line that does not require transmission. Leave only the lines you need and overwrite and save csv file.



### Caution

**Do not change the name of transmission command list file (.csv).**  
**If the name is changed, it does not match to the barcode of previously created pattern name and csv file can not be found.**

	A	B	C	D	E	F	G	H	I
3	01060096	Execution parameter [MODE0] SV Value							
4	010600B4	Execution parameter [MODE0] Event 1 Value							
5	010600B6	Execution parameter [MODE0] Event 2 Value							
6	010600B8	Execution parameter [MODE0] Event 3 Value							
7	010600BA	Execution parameter [MODE0] Event 4 Value							
8	0106009B	Execution parameter [MODE0] P Value							
9	0106009C	Execution parameter [MODE0] I Value							
10	0106009D	Execution parameter [MODE0] D Value							
11	0106009E	Execution parameter [MODE0] Output lower limit Value							
12	0106009F	Execution parameter [MODE0] Output upper limit Value							
13	010600C8	Group parameter [MODE3] SV value No.1							
14	010600FA	Group parameter [MODE3] SV value No.2							
15	0106012C	Group parameter [MODE3] SV value No.3							
16	0106015E	Group parameter [MODE3] SV value No.4							
17	01060190	Group parameter [MODE3] SV value No.5							
18	010601C2	Group parameter [MODE3] SV value No.6							
19	010601F4	Group parameter [MODE3] SV value No.7							
20	01060226	Group parameter [MODE3] SV value No.8							
21	010600E6	Group parameter [MODE3] Event 1 No.1							
22	01060118	Group parameter [MODE3] Event 1 No.2							
23	0106014A	Group parameter [MODE3] Event 1 No.3							
24	0106017C	Group parameter [MODE3] Event 1 No.4							
25	010601AE	Group parameter [MODE3] Event 1 No.5							
26	010601E0	Group parameter [MODE3] Event 1 No.6							
27	01060212	Group parameter [MODE3] Event 1 No.7							

### Reference

For detail of format of transmission telegram, refer to communication interface manual of the controller and general instruction manual of KR.



### Caution

**To avoid unintended setting change, delete a line of telegram which does not need to transmit.**



6. Insert CF card with transmission command list file (.csv) to KR.  
Check that transmission command list file (.csv) is in recipe folder in the CF card.
7. Scan barcode of pattern name by the barcode reader.  
Scan the barcode of print-out barcode file by the barcode reader. For KR, write parameters written in csv file stored in recipe folder in the CF card to the controller by communication.  
Check that send parameters and the parameters set to the controller match.

**Reference**

If there is error response on the communication or communication abnormality happens, [Failed to write the file.] is displayed.

**Caution**

**To check if the parameters are set correctly, perform a test run.**

## 12-5 DP-G parameter setting

DP-G's parameters can be written and read through communication or CF card. Save created DP-G parameter as parameter setting file (\*.ds1/ 2/ 3), program pattern setting file (\*.dp1/ 2/ 3) or \*.pasconf file. (\*.pasconf file includes both ds and dp parameters and pattern information.) To perform setting of DP-G device itself using CF card, parameter setting file (\*.ds1/ 2/ 3) and program patter setting file (\*.dp1/ 2/ 3) are saved in CF card

\*DP-G is supported from TRAMS IV.

### 12-5-1 Cautions when reading patterns in communication

Parameter reading of DP-G is different from specification of other devices'.

If reading parameters of DP1000G, DP2000G or DP3000G by clicking [Specify Registered Device] button, parameter other than MODE 2 program pattern and MODE 2 pattern list.

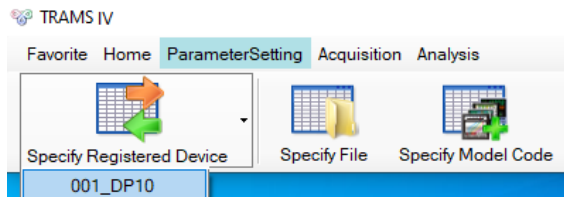

Since large number of patterns and steps can be set to DP-G, it takes time to load all the program patters. So, specification of TRAMS is made not to load individual patterns at first, but only loads pattern list.

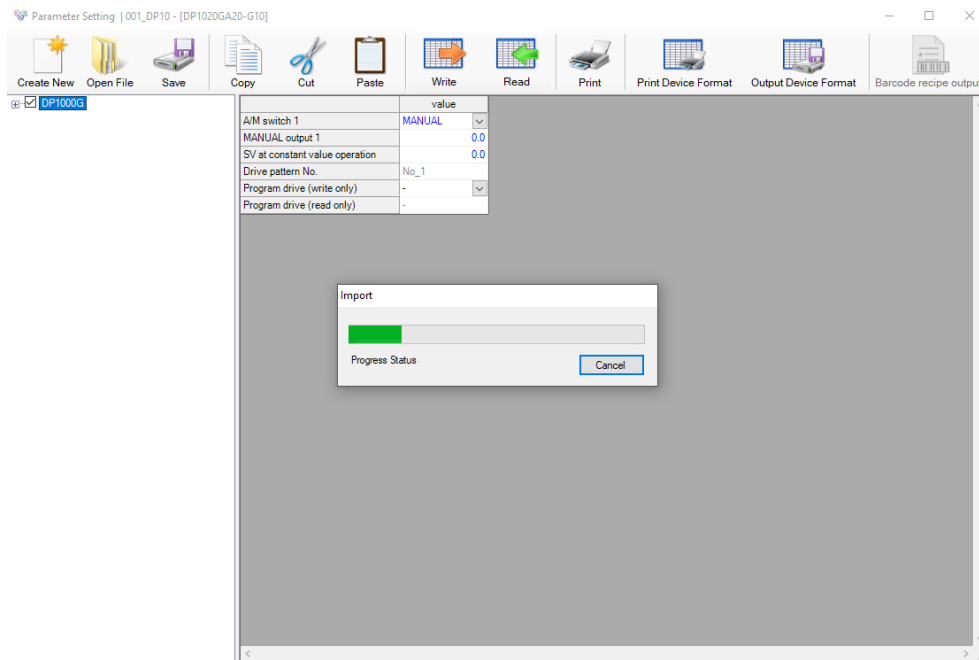

If pattern is set, step number and pattern number of link pattern No. are written in loaded pattern list ((1)). Mark the pattern intended to load ((2)), click read again to load individual pattern ((3)).

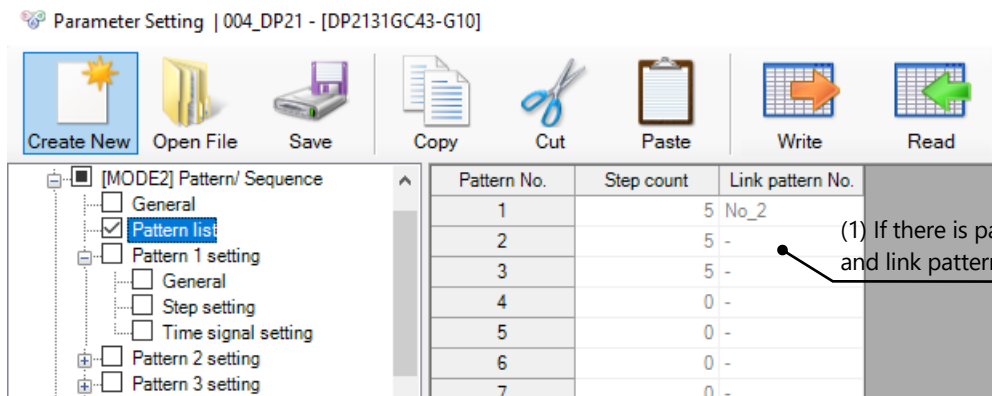

(1) If there is pattern setting, step number and link pattern No. are loaded.

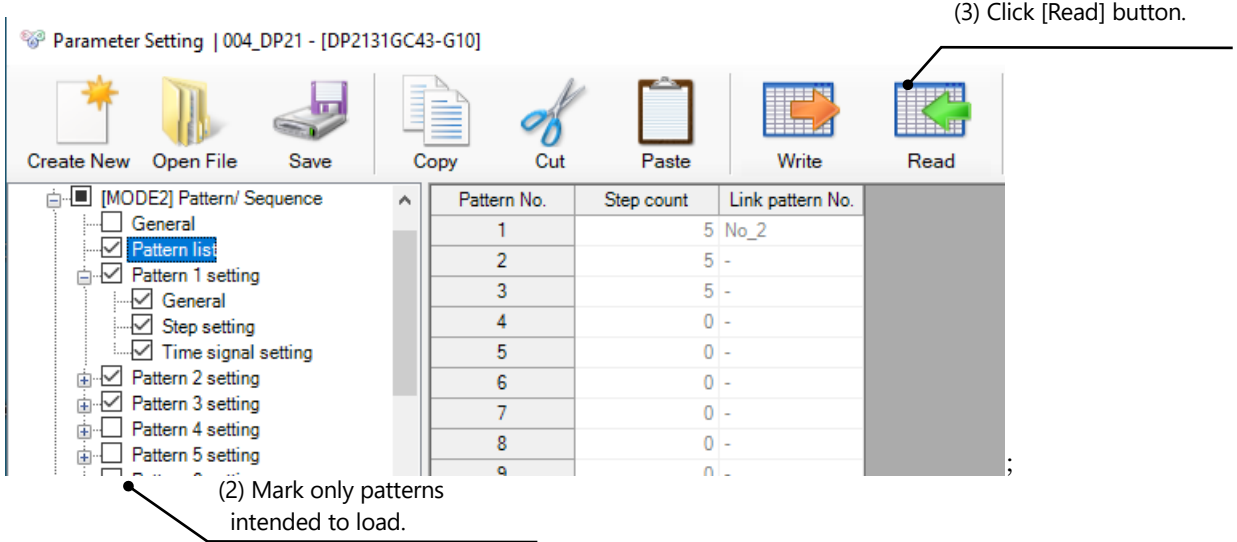

**12-5-2 Cautions on DP-G parameter setting**

**Caution**

If **MODE 10** Extended settings-Enhanced setup-Time unit is changed, it affects other time parameters. If **MODE 5** input setting is changed, it may cause changes of other related parameters. If time setting or input setting of DP-G device itself and of TRAMS window do not match, a value not intended by the user may be set to the other parameters in the DP-G device itself. So for that reason, if changing these settings, check other parameters as well, that there is no difference between the software and DP-G setting.

**12-5-3 Parameter file saving**

To save created parameters and patterns, click [Save] button. At this point, whether the check box of tree view on the left is marked or not, parameters are saved.

[Do you want to save in \*.dsX, \*.dpX format?] message is displayed.

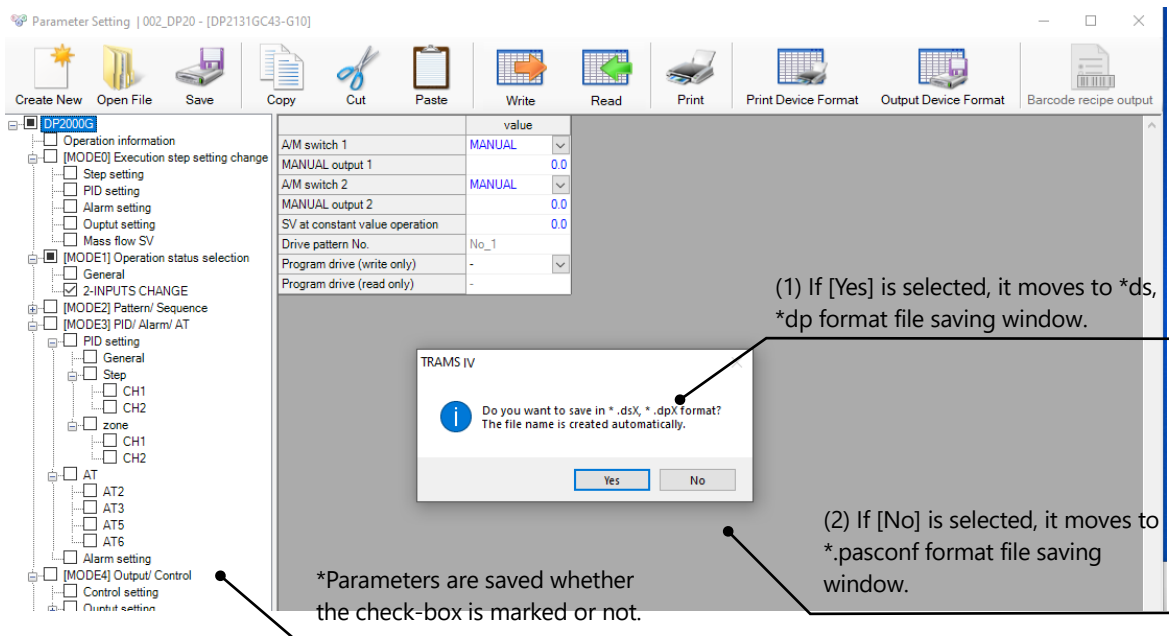

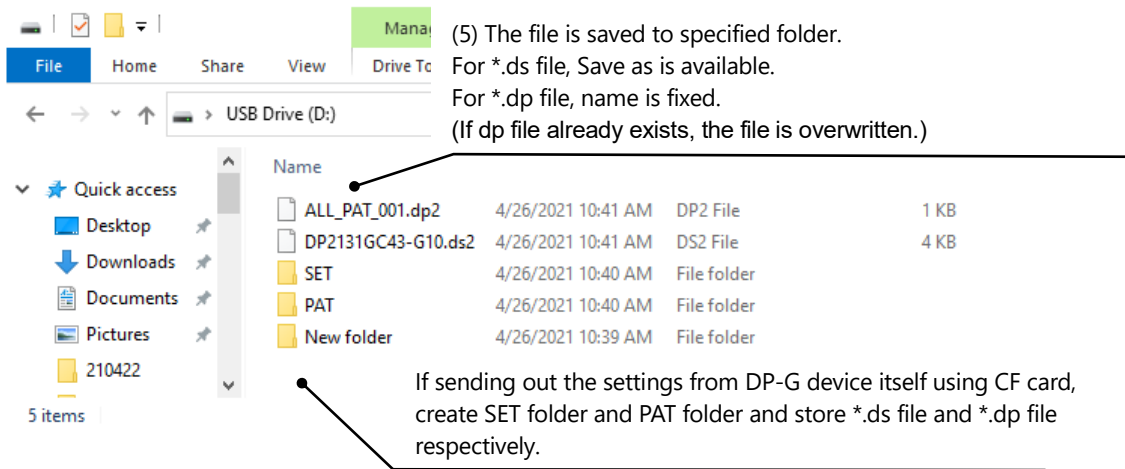
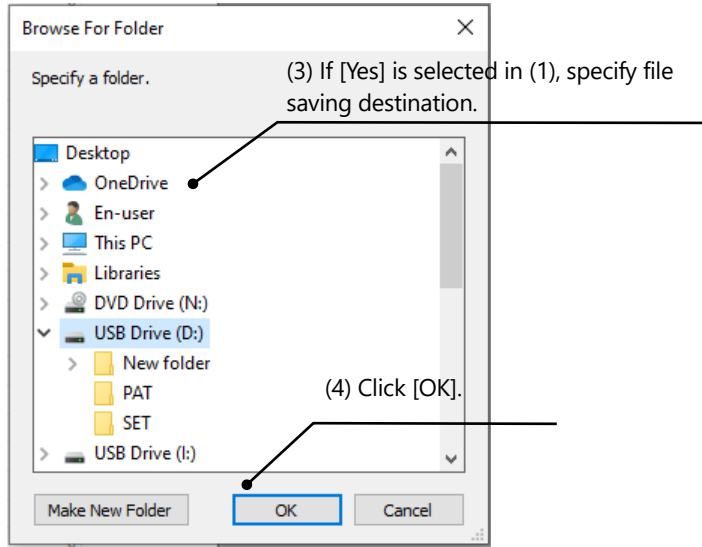

**Caution** SET folder and PAT folder are not created automatically at saving setting file in TRAMS. Created them if necessary. For detail of parameter load or saving via CF card, refer to general instruction manual of DP-G.

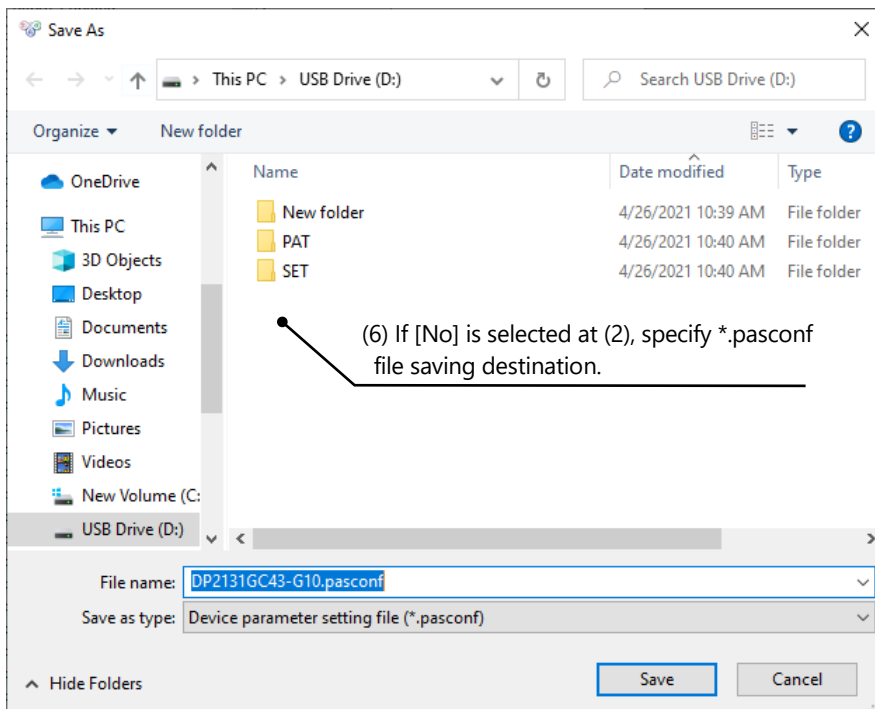

## 12-5-4 How to open parameter file

There are four ways to open parameter file.

- (1) Drag and drop a file to launcher window.
- (2) Open from [Specify File] button.
- (3) Open from [Open file] button.
- (4) Drag and drop a file to parameter setting window.

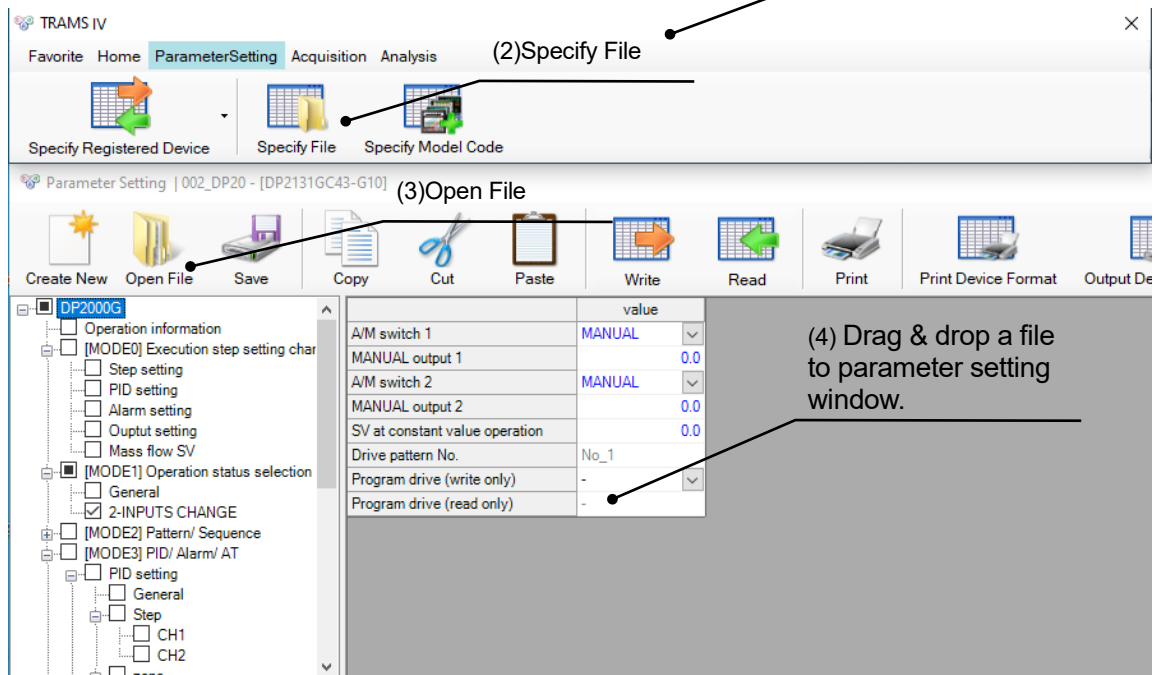

### Reference

#### Difference of parameter file opening

If the file is opened from (1) Drag and drop a file to launcher window or (2) Open from [Specify File] button, it is opened in separate window.

If the file is opened from (3) Open from [Open file] button or (4) Drag and drop a file to parameter setting window, [Shall we overwrite current setting?] is displayed. If [Yes] is selected, current setting is overwritten and displayed.

### Reference

#### Opening \*.ds file and \*.dp file at once

Select multiple files, and then drag and drop or from [Open file] button, select multiple files.

## 12-5-5 Writing parameter through communication

Mark categories to write and click [Write] button. Blue letter parameters of marked categories is to be written.

Parameter Setting | 004\_DP21 - [DP2131GC43-G10]

Create New Open File Save Copy Cut Paste Write Read Print Print Device Format

DP2000G

- Operation information
- [MODE0] Execution step setting change
- [MODE1] Operation status selection
- [MODE2] Pattern/ Sequence
- [MODE3] PID/ Alarm/ AT
- [MODE4] Output/ Control
- [MODE5] Input
  - input setting
  - Sensor correction
  - Linearize table
- [MODE6] TS/ GS
- [MODE7] Transmission
- [MODE8] Communication
- [MODE10] Extended settings

	CH1 (high region)	CH2 (low region)
Range No.	10mV	K1
RJ	EXT	EXT
Unit	°C	°C
Linear range span	10.00	20.0
Linear range zero	0.00	0.0
Scale maximum	9999.0	1370.0
Scale minimum	0.0	-200.0
Scale decimal point	1	1
PV display decimal point	1	1
Digital filter [S]	0.1	0.1
Burn out action	UP	UP
Input calculation	None	None



### Caution

Following parameters of MODE 10 Extended settings-Enhanced setup do not have communication reference, therefore they can not be read or written through communication.

- DO status during FAST
- Output setting method  
(Initial values are displayed when loaded from DP-G)

These contents of the parameters are output to \*.ds file. Output setting method is also used for display parameter switching at MODE 4 Output setting window. To set above two parameters, set via CF card or reflect them to DP-G device operation.

## 12-6 Kps Viewer

Open the setting file (\*.kps) of the KR Heat Treatment Assistance Specification.

**Reference** Kps files cannot be opened using the [Specify File] button, [Specify model code] button, drag-and-drop, or double-click.

Click the [kps Viewer] icon on the launcher window.

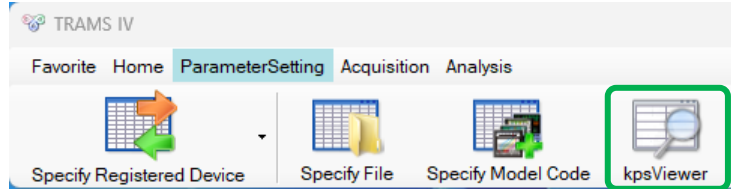

Click [Yes].

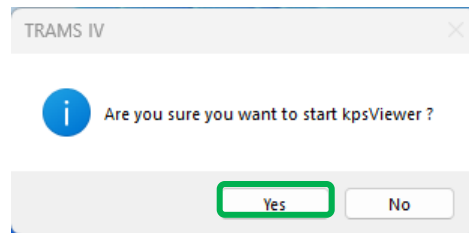

[Setting Parameter List] window is displayed. Click on the [Option] button for the first time only. (Set the language preference)

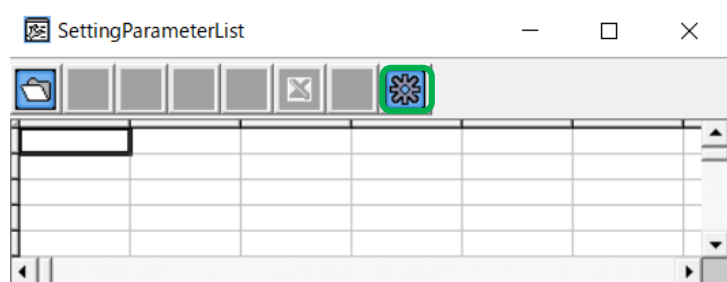

Select the language you want to display and click the [OK] button.

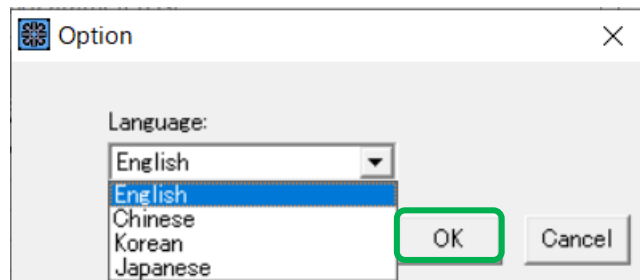

Click on the [Open] button.

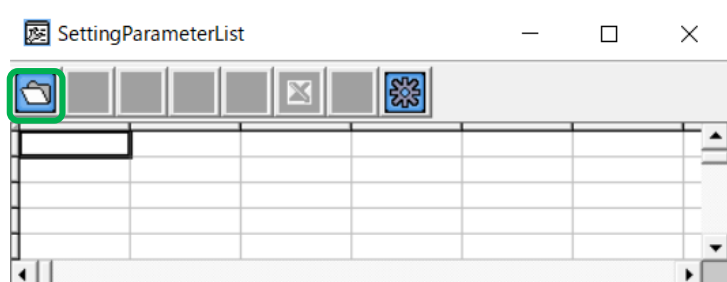



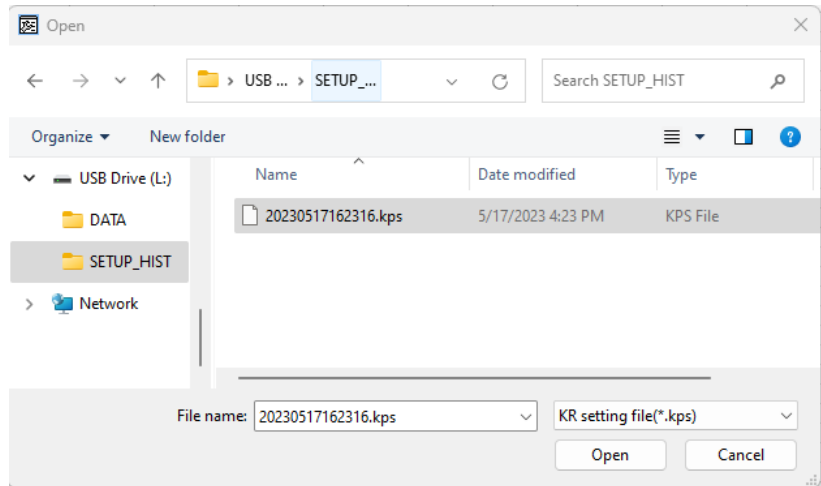



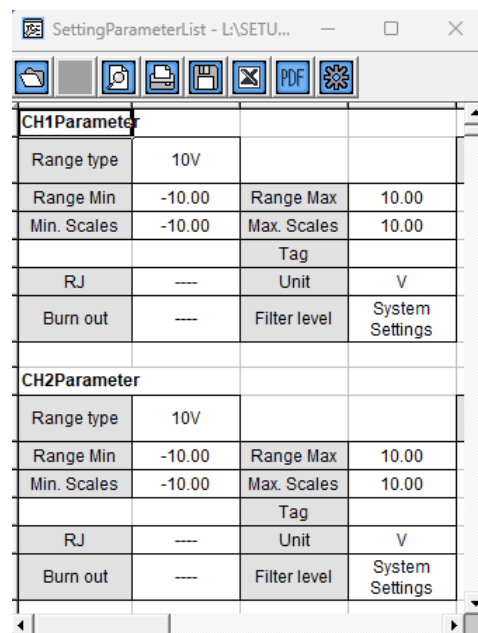

Select the file and click the [Open] button.



Check the contents of the setting file.



	A file selection dialog is displayed. Select the setting file.
	Compares open files. This can be used when multiple files are opened.
	A print preview is displayed.
	Print.
	Save the contents of the screen to a CSV file.
	Export to Excel. Excel automatically starts and displays the graph. Excel is required for display.
	Output to the PDF file. Adobe Acrobat needs to be installed in order to output.
	Sets the language to be displayed.



# 13 Data acquisition

## 13-1 Data acquisition operation

At data acquisition, it performs acquisition/ data memory (file saving)/ real time trend display (graph display)/ real-time data display (numeric value display).

### Reference

Difference of acquisition data memory

Acquisition and data memory is different.

Acquisition is to obtain data by TRAMS's communication through device. Obtained data is displayed as real time trend, real-time data or used for data memory. Data obtained by acquisition is held internally, so the use can not use this data as is.

On the other hand, data memory means the user saving the data being acquired by TRAMS as a file (extension: .dmf). If the user preferred to save data form device, start the data memory. File saved by data memory (extension: .dmf) can be opened as shown in 14. Data analysis. Data can be output (export) to CSV, text, and Excel files as shown in 14-3-1. Data list display window.

To do data acquisition, following 3 preparations are necessary. Red letter part is required item.

1. Register data. Perform alarm setting (Alarm setting is optional)
2. Register data groups.
3. Start data acquisition.

**(Note) If data acquisition is not started, subsequent operation related to data acquisition (trend graph display, numeric data display, data memory operation) can not be done.**

### < Names of Parts on launcher data acquisition (Unacquired state)>

This window is displayed by following operation. [TRAMS]→[Data acquisition]→(at unacquired)

**\*Tool buttons at invalid state become effective at acquisition start.**

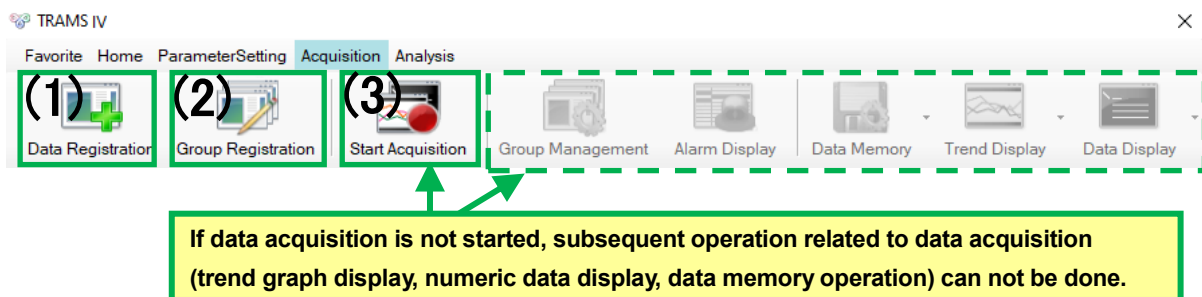

Num.	Name	Descriptions	Reference
(1)	Data Registration	Displays data registration window. It performs registration/ edit/ delete for data for acquisition.	13-2
(2)	Group Registration	Displays group registration window. It performs editing of group for acquisition. *If data for acquisition registered at (1) Data registration is not registered for group, it is excluded from data acquisition.	13-3
(3)	Start Acquisition	Starts data acquisition.	

  
**Caution**

**Data acquisition through USB communication can not be done.**

TRAMS IV ✕

 Data acquisition via USB communication is not supported.  
Check the communication setting of the registered device.

### < Names of Parts on launcher data acquisition (Acquiring state) >

This window is displayed by following operation. [TRAMS]→[Data acquisition]→(acquiring)

**\*Data registration/ group registration and port registration/ device registration of home function tool buttons are invalid while acquisition.**

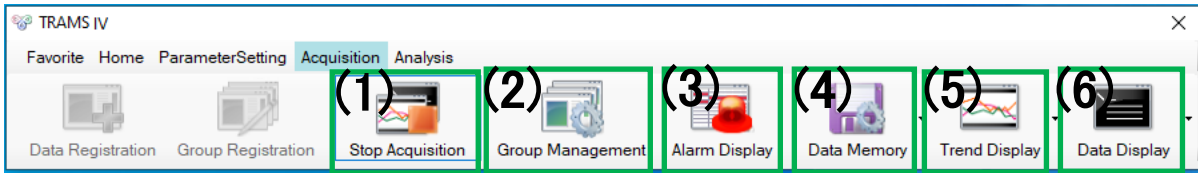

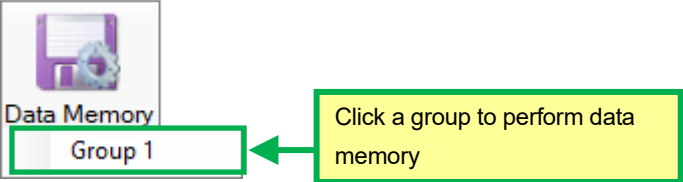
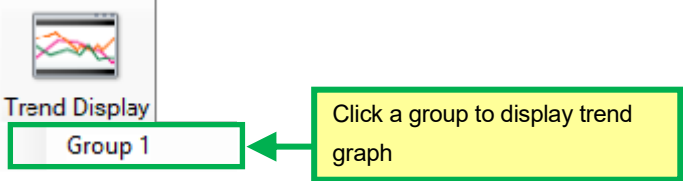
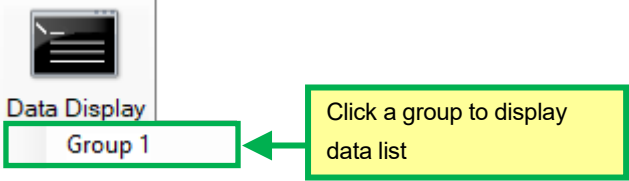
Num.	Name	Descriptions	Reference
(1)	Stop Acquisition	Stops data acquisition.	
(2)	Group Management	Start/ Stop of acquiring group recording (data memory) and monitors alarm status.	13-4
(3)	Alarm Display	Displays acquiring group, alarm status of each acquiring data and contents of alarm as real-time display.	13-5
(4)	Data Memory	<ul style="list-style-type: none"> <li>By clicking drop-down button, a list of acquiring group is displayed.</li> <li>Select and click a group from the list to perform data memory.</li> </ul>  <ul style="list-style-type: none"> <li>Displays data memory operation window.</li> </ul>	13-6
(5)	Trend Display	<ul style="list-style-type: none"> <li>By clicking drop-down button, a list of acquiring group is displayed.</li> <li>Select and click a group from the list to display trend graph.</li> </ul>  <ul style="list-style-type: none"> <li>Displays trend graph window.</li> </ul>	13-7
(6)	Data display	<ul style="list-style-type: none"> <li>By clicking drop-down button, a list of acquiring group is displayed.</li> <li>Select and click a group from the list to display data list.</li> </ul>  <ul style="list-style-type: none"> <li>Displays real-time data list display window.</li> </ul>	13-8

#### Reference

For parameter reading and writing while data acquisition  
 If parameters are read or written during data acquisition, communication of data acquisition pauses.  
 For that reason, stop data memory first and perform parameter writing.

## 13-2 Data registration window

Performs registration/ edit/ delete of data intended to acquire.

**\*Data that supports the acquisition of the device registered on 8. Device registration window is target.**

### < Names of Parts on data registration window >

The window is displayed by following operation.

[TRAMS]→[Data acquisition]→[Data registration]

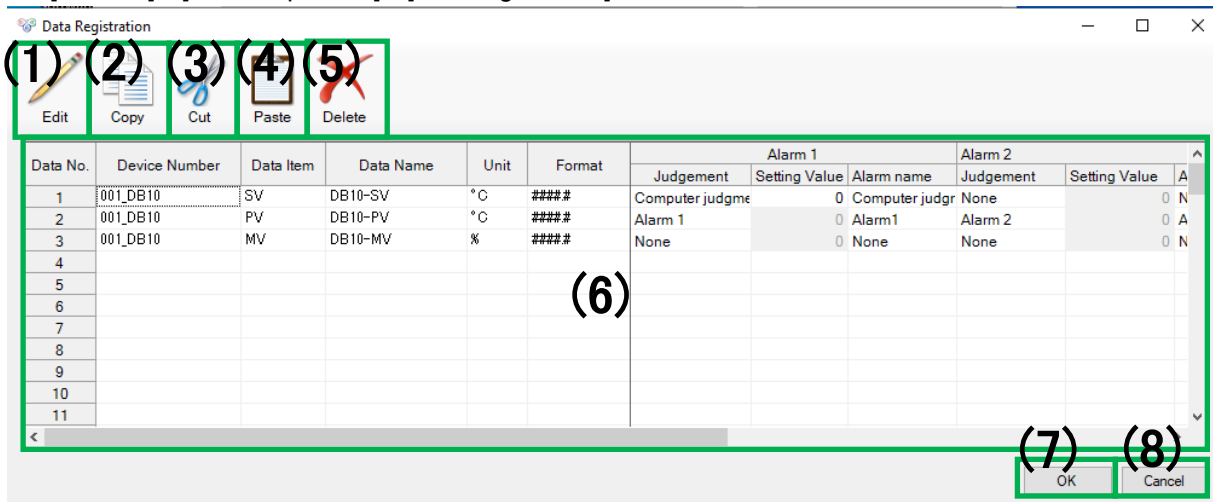

Num.	Name	Descriptions	Reference
(1)	Edit	Displays data edit window.	12-2-1
(2)	Copy	Copies setting information of selection on the list of data setting information for acquisition. *Short cut is available as Ctrl + C keys. *It initializes belonging group.	
(3)	Cut	Cuts setting information of selection on the list of data setting information for acquisition. *Short cut is available as Ctrl + X keys. *It initializes belonging group.	
(4)	Paste	Pastes setting information obtained by (2) Copy or (3) Cut after the selected line. *Short cut is available as Ctrl + V keys	
(5)	Delete	Deletes selected registered data setting information for acquisition. *Multiple deletion is available.	
(6)	List of data setting information for acquisition	Displays currently registered list of data setting information for acquisition. *If OK button is clicked on device registration window, data is automatically reflected to (6) list of data setting information for acquisition. (Function after TRAMS III version 3.0.0.4) *By double clicking on a cell, data setting for acquisition of subjected line can be done. It displays data edit window as (1). *Up to 300 data can be registered. *It can copy and paste to EXCEL and change its name then paste back to the original place. (Function after TRAMS III) This is convenient when changing the name with serial numbers. In that case, copy whole line. Copying and pasting only a part of the cell can not be done. If edited	

		contents are not correct, it can not be pasted and be blank when pasted back. Check the contents and edit.	
(7)	OK	Reflects contents of registration/ editing/ delete.	
(8)	Cancel	Cancels contents of registration/ editing/ delete.	

### Reference

For function that reflects data items automatically at device registration (Function from TRAMS III version 3.0.0.4)

By clicking OK button on device registration window, data is reflected on data registration window automatically.

However, if data item exceeds its maximum number 300 available to be register, subsequent data items are not be added. Delete and revise data item if necessary.



### Caution

#### If TRAMS is returned to previous version

**After registering data (device registration) by TRAMS III version 3.0.0.4 or later, uninstall the software and install previous version of the software, all setting contents of data registration window are deleted. This happens because alarm name setting field is added to the software version 3.0.0.4 or later. So, please be noted.**

### 13-2-1 Data edit window

Edits data setting for acquisition.

#### < Names of Parts on data editing window >

The window is displayed by following operation.

[TRAMS]→[Data acquisition]→[Data registration]→[Edit]

The screenshot shows the 'Data Edit' window with the following fields and buttons:

- (1) Device Number: 006\_KR2S
- (2) Data Item: CH1 Measured data
- (3) Data Name: KR2S-CH1 Measured data
- (4) Unit:
- (5) Format: ####.#
- (6) Alarm 1 Type: CH1 Alarm 1
- (7) Alarm 1 Value: 0
- (8) Alarm 1 Name: CH1Alarm1
- (9) OK button
- (10) Cancel button

Num.	Name	Descriptions
(1)	Device name	Select the device name to perform data acquisition. *Only a device which is registered at 8. Device registration window with data for acquisition can be selected.
(2)	Data item	Select a type of acquiring data which is held by a device specified at (1). *Type of acquiring data varies depending on a device specified.
(3)	Data name	Specify display name for acquiring data. Up to 30 letters can be input. If the data is registered automatically at device registration, default name is to be set. Change it if necessary.
(4)	Unit	Specify display unit for acquiring data. Up to 30 letters can be input.
(5)	Format	From #####/ #####.# / ###.##/ ##.###/ #.#####/ 0E+00/ 0.0E+00/ 0.00E+00/ 0.000E+00, select and specify a format for acquiring data display.
(6)	Alarm 1 to 4 Type	Select and specify an alarm type. *Alarm type varies depending on specified device or acquiring data.
(7)	Alarm 1 to 4 Alarm value	Specify alarm value of alarm type specified at (6) from -99999.9999 to 99999.9999. *Alarm type: this is only valid if computer judgment (higher limit)/ computer judgment (lower limit) is specified. For other alarms, it depends on the device.
(8)	Alarm name setting row	Set alarm name to store acquired data file (up to 30 letters). This is available to be set if (6) Alarm type is set.
(9)	OK	Reflect edited contents to data registration window.
(10)	Cancel	Cancels edited contents and returns them to a state previous to editing.

Reference

At acquiring by DP2000G  
 At (2) Data item, SW (2-input switch status) can be set.  
 SW=0: low region side sensor selected.  
 SW=1: high region side sensor selected.  
 (Function from TRAMS IV)

Reference

For (6) Alarm 1 to 4 type  
 From selection, select computer judgment or device judgment (Alarm 1 to )  
 Selection differs depending on the device or selected data item.  
 For LTA, alarm 1 to 5 can be set for device judgment (it is equivalent to internal event 1 to 5 of LTA).

### 13-3 Group registration window

Performs data add/ delete, or other settings to acquisition group.

#### <Names of Parts on group registration window>

The window is displayed by following operation.

[TRAMS]→[Data acquisition]→[Group registration]

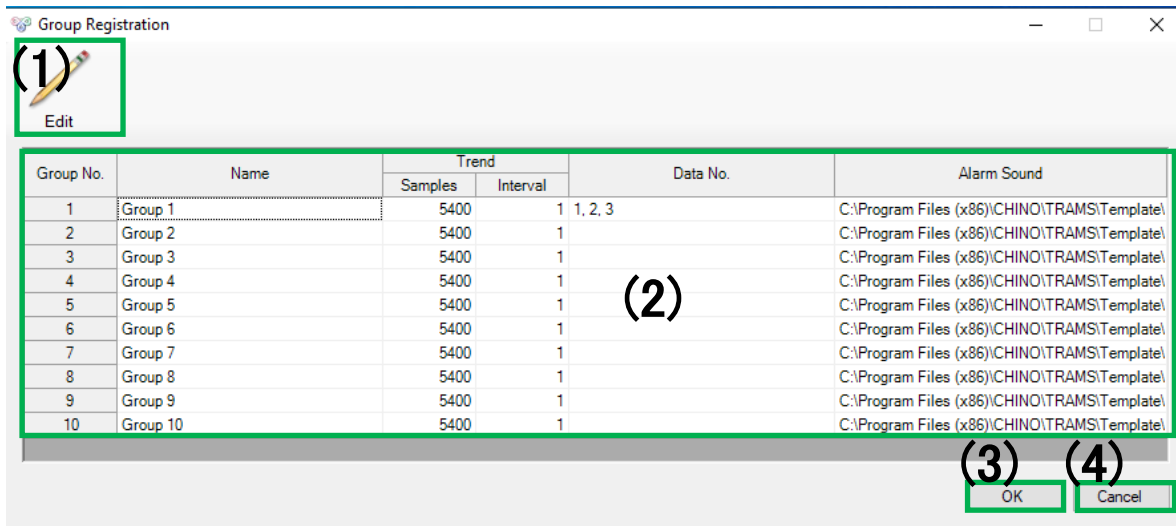

Num.	Name	Descriptions	Reference
(1)	Edit	Displays group edit window from selected acquisition group setting information.	13-3-1
(2)	Group setting information display	Displays list of acquisition group setting information. Up to 30 groups can be set. However, the maximum number of groups that can communicate simultaneously is 10. *By double-clicking on a cell, acquisition group setting of subject row becomes available. It displays group edit window as (1).	
(3)	OK	Reflect edited contents.	
(4)	Cancel	Cancels edited contents.	

## Caution

**When device is registered at device registration window, data items are set to the data registration window automatically, (function from TRAMS III version 3.0.0.4) but, group registration is not done. Register group manually.**

**\*If group registration is not done, data acquisition can not be performed.**



### 13-3-1 Group edit window

Edit acquisition group setting information.

#### < Names of Parts on group edit window >

The window is displayed by following operation.

[TRAMS]→[Data acquisition]→[Group registration]→[Double-click on the row of group intended to edit]

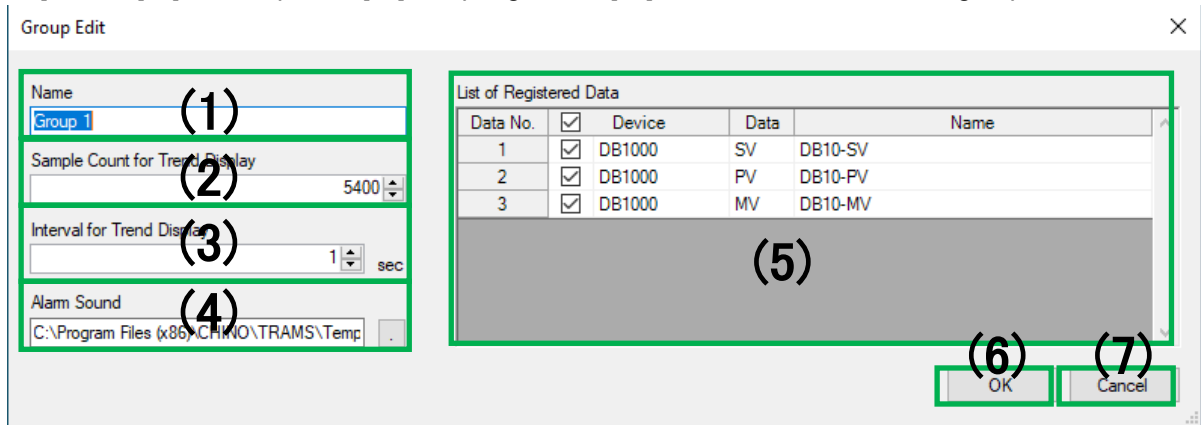

Num.	Name	Descriptions
(1)	Group name	Specify display name of acquisition group. Up to 30 letters can be input.
(2)	Sample count for Trend Display	Specify trend sample count from 1 to 5400. Initial value: 5400 If 5400 is set, it saves data up to 5400 and when data exceeds 5400 samples, it deletes data from the old data.
(3)	Interval for Trend Display	Specify trend display interval from 1 to 3600sec. Initial value: 1sec
(4)	Alarm Sound	Select and specify alarm audio from *.wav format files.
(5)	List of Registered Data	List of data for acquisition registered at 13-2. Data registration window is display. With check mark: include in a group No check mark: exclude form a group Up to 50 data can be set to one group. All can be selected by marking the top checkbox.
(6)	OK	Reflect setting to the group registration window.
(7)	Cancel	Cancels setting and returns it to a state previous to editing.

Reference	Data saving period of trend graph of data acquisition
	Data saving period of trend graph of data acquisition can be calculated by the following formula. Data acquisition trend graph data saving period (sec) = Trend display sample count ((2)) × Trend display interval ((3))

Reference	Using data of trend graph of data acquisition
	Trend graph data of data acquisition can be checked at data acquisition trend graph window. (User can not perform operation such as manipulating this graph data etc.)



## Caution

If trend display interval is changed, trend graph data of data acquisition is initialized. If it exceeds trend display sample count, data is deleted from the old data. For aiming to save or store data, use 13-6. Data memory function.

### 13-4 Acquisition group management window

Displays acquisition group alarm status and starts/ stops data memory.

#### <Names of Parts on acquisition group management window>

The window is displayed by following operation.

[TRAMS]→[Data acquisition]→[Acquisition start]→[Group management]

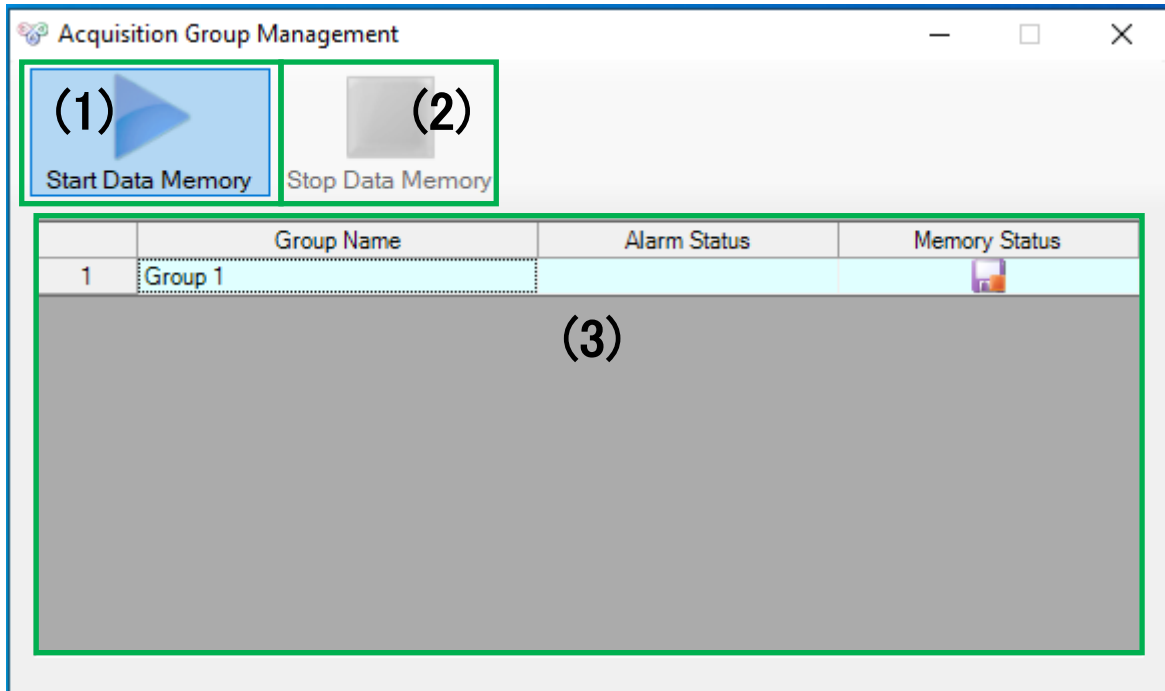

Num.	Name	Descriptions
(1)	Data memory start	Starts data memory of selected row acquisition group. *At start/stop, valid/ invalid of the buttons are switched. *For detail setting of data memory, refer to 13-6. Data memory operation
(2)	Data memory stop	Stops data memory of selected row acquisition group. *At start/stop, valid/ invalid of the buttons are switched.
(3)	Acquisition group list display	Displays a list of currently recording information of acquisition group. Information such as group name, alarm status and memory status are displayed. <b>[Alarm status]</b> If there is alarm activated data exist in the acquisition group, following icon is displayed. ...Alarm activated <b>[Memory status]</b> Status of data memory is displayed by following 4 types of icons. ...Stop (data memory is not running) ...Recording (data memory is running and it is outputting file) ...Waiting (data memory is running, but waiting for file output) *It happens only if time is specified for memory mode. ...Abnormal (data memory is failing for some reasons) *Error information can be checked at 8. Summary display

### 13-5 Alarm display window

Alarm status is displayed and can be checked by acquisition data.

#### <Names of Parts on alarm display window>

The window is displayed by following operation.

[TRAMS]→[Data acquisition]→[Acquisition start]→[Alarm display]

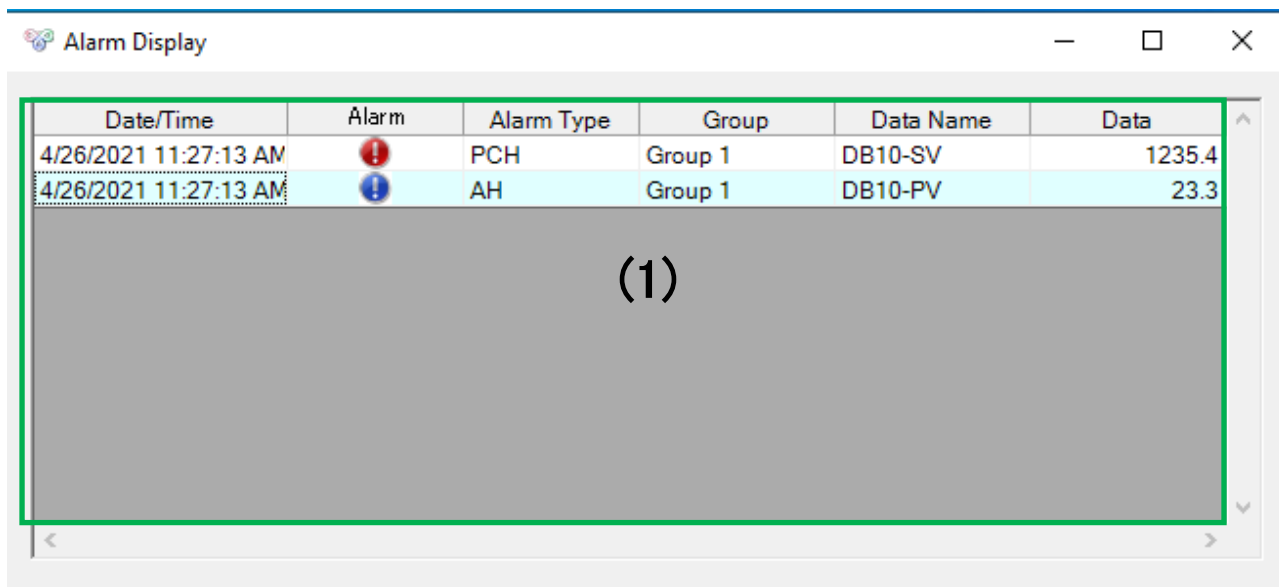

Num	Name	Descriptions
(1)	Alarm list display part	<p>It displays currently activated alarm and the alarm activated in the past in the list. Activated alarm's date and time, alarm, alarm type, belonging group, data name and acquiring data are displayed as information.</p> <p>[Alarm]</p> <p>Status of activated alarm are displayed by following 3 types of icon.</p> <ul style="list-style-type: none"> <li> ...Alarm activated/ user not checked yet (red)</li> <li> ...Alarm activated/ user checked already (blue)</li> <li> ...Alarm activated→alarm canceled/ user not checked yet (yellow)</li> </ul> <p>*By clicking on an icon of alarm column, it is judged as the alarm is checked by the user. At the check, icon change or deletion of alarm information are done. If alarm audio is set to the group which subject alarm is activated, alarm audio is stopped by alarm cancel and after the user confirmation.</p> <p>[Alarm type]</p> <ul style="list-style-type: none"> <li>PCH ...higher limit alarm (computer judgement)</li> <li>PCL ...lower limit alarm (computer judgement)</li> <li>H ...higher limit alarm (device judgement)</li> <li>L ...lower limit alarm (device judgement) etc.</li> </ul>

### 13-6 Data memory operation window

Performs data memory setting and control for acquiring group.

**\*Setting information saving is done when starting the data memory or closing the window. Saving confirmation dialog is displayed only when closing the window after editing setting information.**

**<Names of Parts on data memory operation window>**

The window is displayed by following operation.

[TRAMS]→[Data acquisition]→[Acquisition start]→[Data memory]

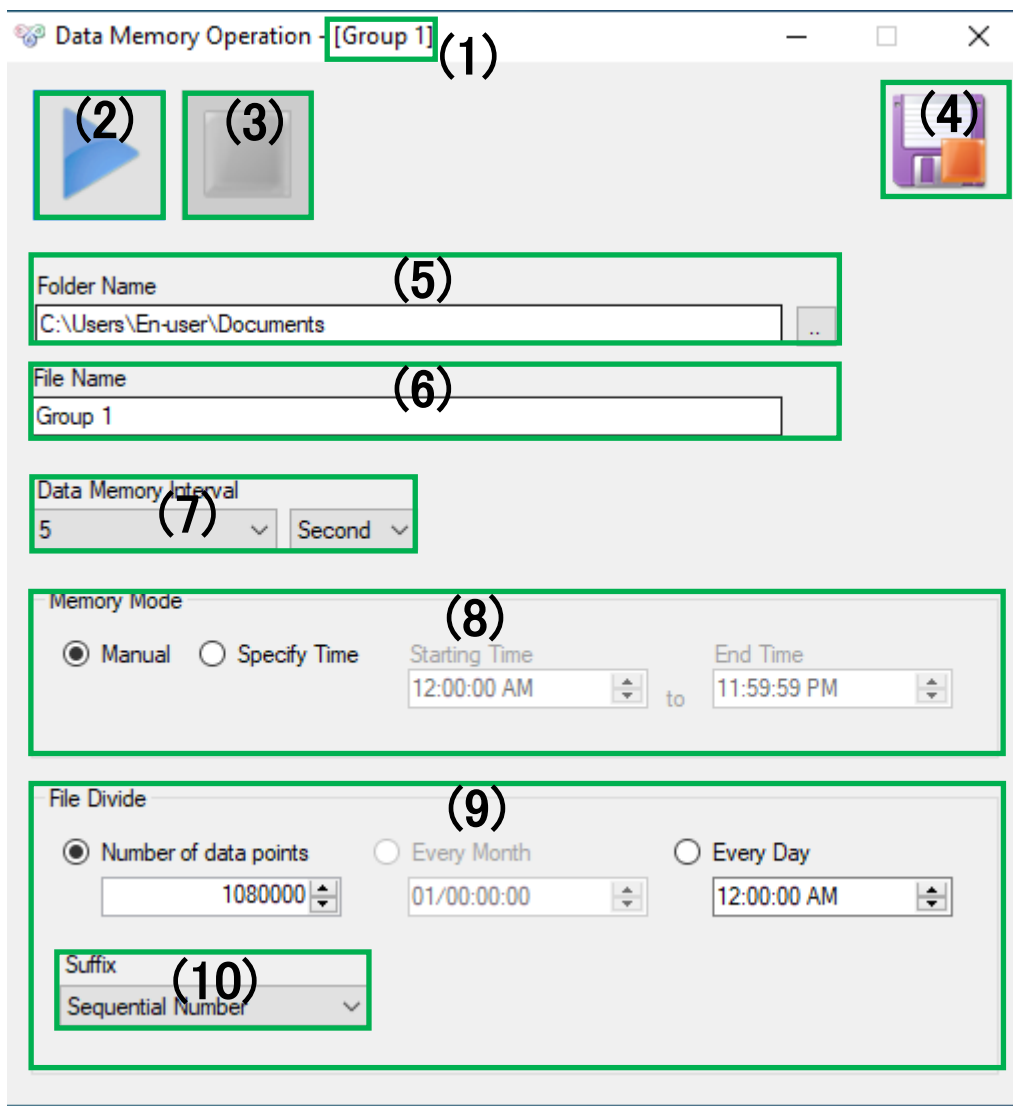

Num.	Name	Descriptions
(1)	Acquisition group name	Displays the name of selected acquiring group.
(2)	Data memory start	Starts data memory. *At start/stop, valid/ invalid of the buttons are switched. Data memory continues if data memory operation window is closed while data memory is running.
(3)	Data memory stop	Stops data memory. *At start/stop, valid/ invalid of the buttons are switched.
(4)	Data memory status	Displays data memory status of subject acquiring group. *As status changes, display is switched in real-time.

Num.	Name	Descriptions
(5)	Output destination folder	Specify saving destination folder. *Direct input can not be done. If specified folder does not exist when data memory is starting, TRAMS creates new folder by same name and saves data file in the folder. If specified drive does not exist when data memory is starting or there is no free space for output destination, it becomes error.
(6)	File name	Specify saving file name.
(7)	Data memory interval	Select and specify data memory interval from following. 1 to 30 [sec] 1 to 30 [min] 1 to 12 [hr.] 1 [day]
(8)	Memory mode setting part	Select and specify memory mode from manual/ specify time. *If specify time is selected, assign start time/ end time. *Same times are not be able to assign for start time / end time. Continuous data memory is available by setting times shift by one second like start time 00:00:00 and end time 23:59:59.
(9)	File division setting part	Select and specify file division types from data point/ every month/ every day. The file is divided at data memory according to the specified condition. *This setting is a timing setting which divides the file at data memory by adding suffix. *Data point means total data points at data memory. If setting is 50 registered data, data memory interval is 1 sec and 1080000 data points, the file is divided to next file after 6 hrs. *If every month is specified, assign date and time of file division (to select every month, set (7) Data memory interval 5 min or more). *If every day is specified, assign time of file division (to select every day, set (7) Data memory interval 5 sec or more).
(10)	Suffix	Select and specify character strings added to the end of saving file. Sequential Number yy/MM/dd/hh/mm/ss yy/MM/dd/hh/mm yy/MM/dd/hh yy/MM/dd yy/MM

For data memory running

Data memory continues to run even though data memory operation window is closed while data memory is running.

Data memory is running when start button is grayed out

If this window is closed by clicking ×, running data memory continues

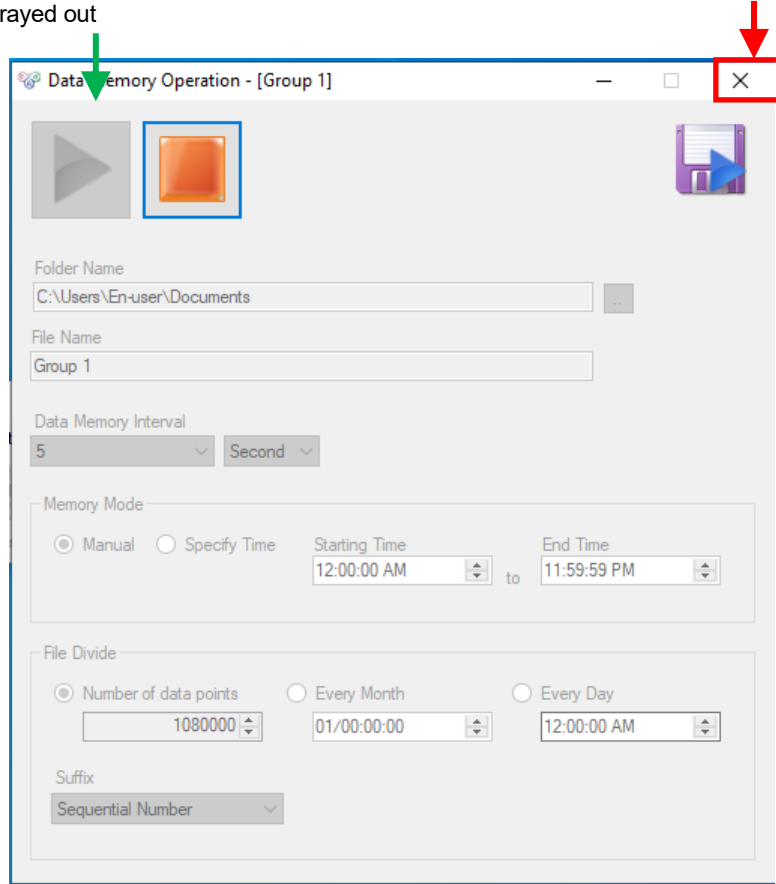

Reference

However, if stops acquisition or exit from TRAMS while data memory is running, data memory ends.

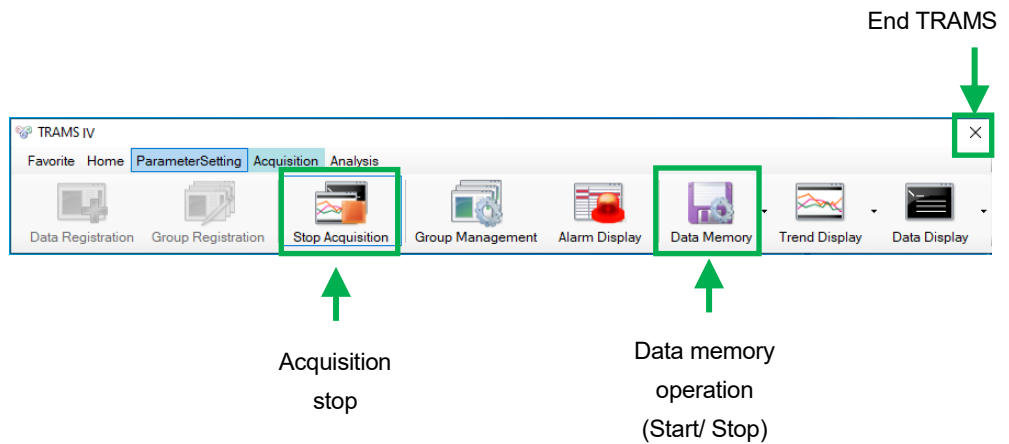

### Cautions at data memory

If specified saving destination drive itself does not exist at starting of data memory, it becomes error [Recording Error].

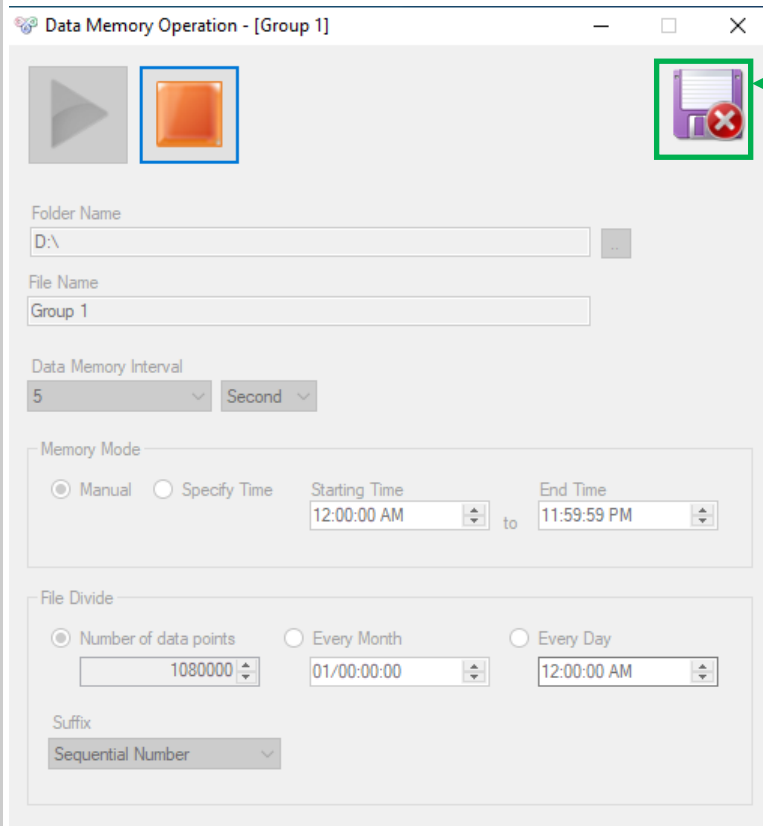

x mark is displayed on the icon

Reference

If there is not enough free space for saving destination, it becomes error [Recording Error].

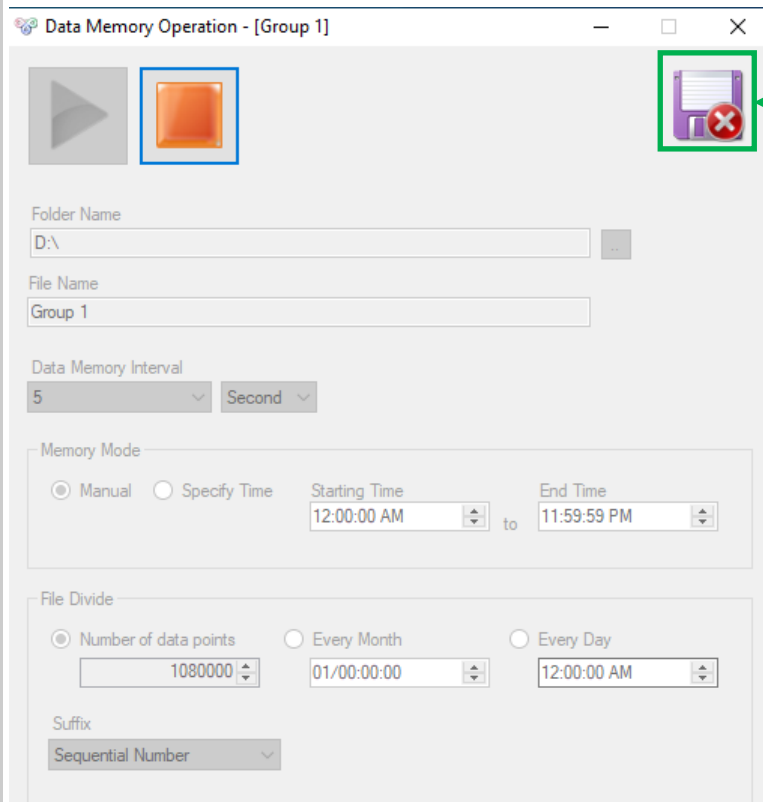

x mark is displayed on the icon

### 13-7 Trend graph display window

Displays acquisition status by acquiring group.

#### <Names of Parts on trend graph display window>

The window is displayed by following operation.

[TRAMS]→[Data acquisition]→[Trend display]→[Select applicable group from drop-down list]

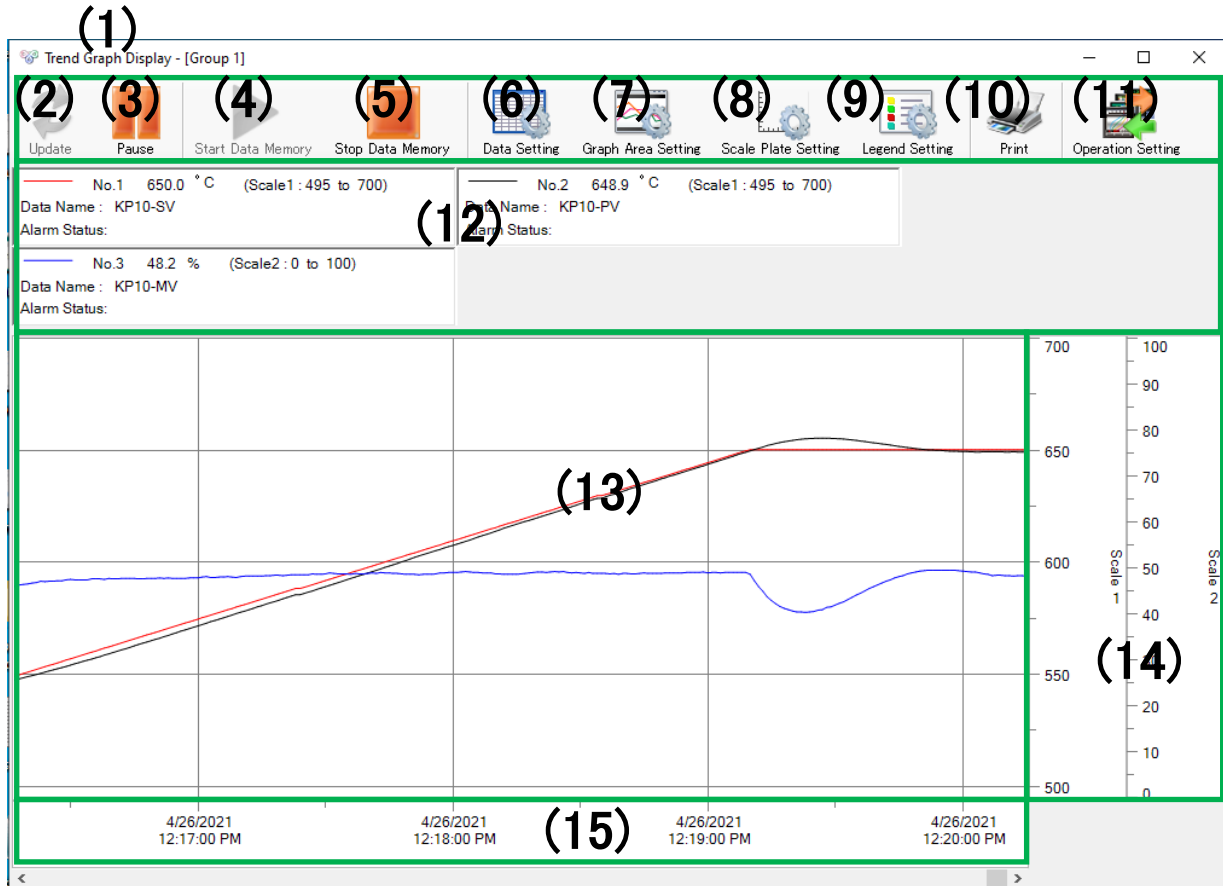



Num.	Name	Descriptions	Reference
(1)	Acquisition group name	Displays selected acquisition group name.	
(2)	Update	If trend graph update is paused, it resumes update. *At update/pause, valid/ invalid of the buttons are switched. *Display position in the graph is scrolled to the latest position.	
(3)	Pause	Pauses update if trend graph is updating. *At update/pause, valid/ invalid of the buttons are switched.	
(4)	Data memory start	Starts data memory. *At start/stop, valid/ invalid of the buttons are switched.	
(5)	Data memory stop	Stops data memory. *At start/stop, valid/ invalid of the buttons are switched.	
(6)	Data setting	Displays data setting window. *Setting information varies depending on every group.	13-7-1
(7)	Graph area setting	Displays graph setting window. *Setting information varies depending on every group.	13-7-2
(8)	Scale plate setting	Displays scale setting window. *Setting information varies depending on every group.	13-7-3
(9)	Legend setting	Displays numeric data setting window. *Setting information varies depending on every group.	13-7-4
(10)	Print	Print out window view. *Displays print preview.	
(11)	Operation setting	It switches RUN/ READY switch of the controller (only if the controller has RUN/ READY) or set execution number. (It does not support LTA series)	13-7-5
(12)	Numeric data display part	Displays information such as data number, legend, data name, numeric data, unit, scale number alarm status etc. for acquiring each data. It also displays by which scale to draw the graph (Scale No: scale min to scale max). (Function from TRAMS III) *If communication abnormality happens and normal data acquisition can not be done, [Invalid] is displayed on the numeric value. If communication can not be continued due to model code of communicating device is different from that of specified in TRAMS etc., data acquisition is skipped and blank (no data) is displayed.	
(13)	Graph area	Acquisition data is drawn in a graph as real-time. Data saving period is decided by trend display sample count x trend display interval set at 13-3-1. Group edit window.	
(14)	Scale plate	Displays scale indicating data area of trend graph. *By dragging display frame of scale plate by mouse to specify the range, display size of scale plate can be changed. *By dragging display area of scale plate by mouse to specify the range, it can enlarge the scale range. To cancel the enlargement, setting needs to be reflected from 13-7-3. Scale plate setting window.	13-7-3-1
(15)	Time axis scale	Displays scale indicating trend graph time series.	

**Reference** For time axis scale  
 If you specify the range with a mouse drag, the scale is enlarged and displayed. (If this operation is performed, update of the trend graph is paused, by clicking (2) Update, enlargement is canceled.)  
 Enlarged time axis returns to initial state by right click.

**Reference** For graph drawing  
 If exit TRAMS and startup TRAMS again, data of which saving period has not elapsed yet (data acquired at previous operation) is drawn.  
 (For data saving period, it is written at 13-3-1. Group edit window)

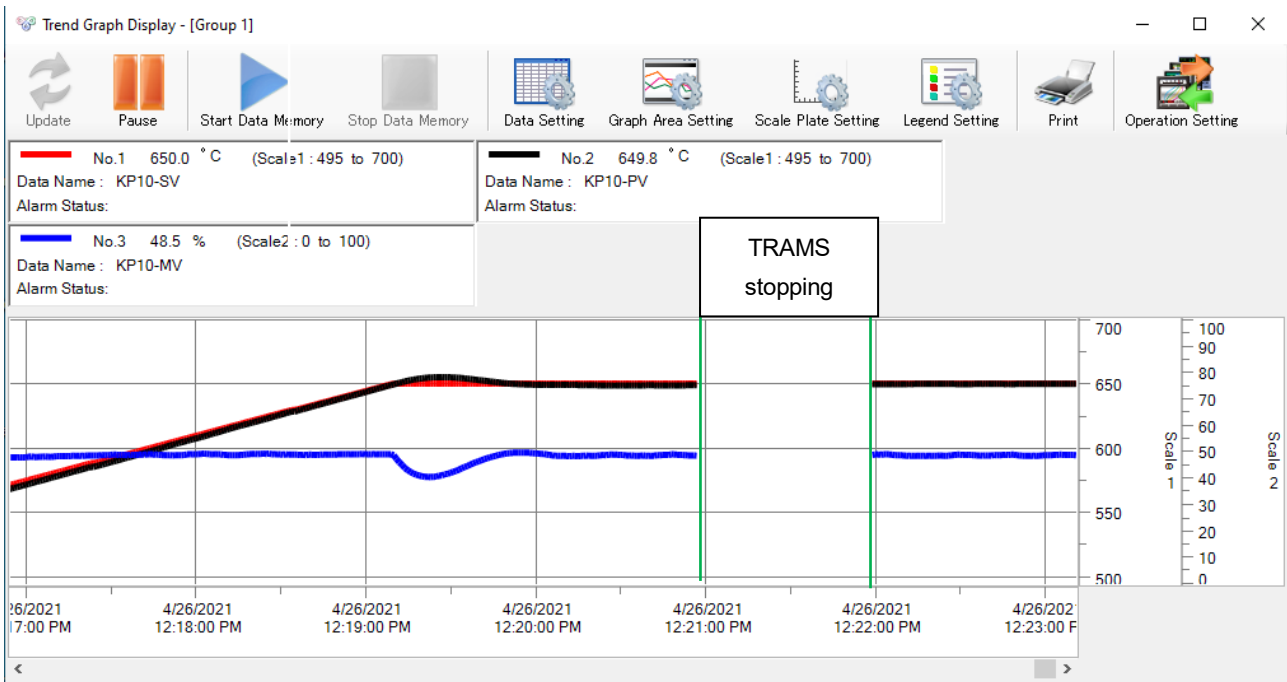

### 13-7-1 Data setting window

Performs changing of data setting of trend graph.

#### <Names of Parts on data setting window>

The window is displayed by following operation.

[TRAMS]→[Data acquisition]→[Trend display]→[Select applicable group from drop-down list]→[Data setting]

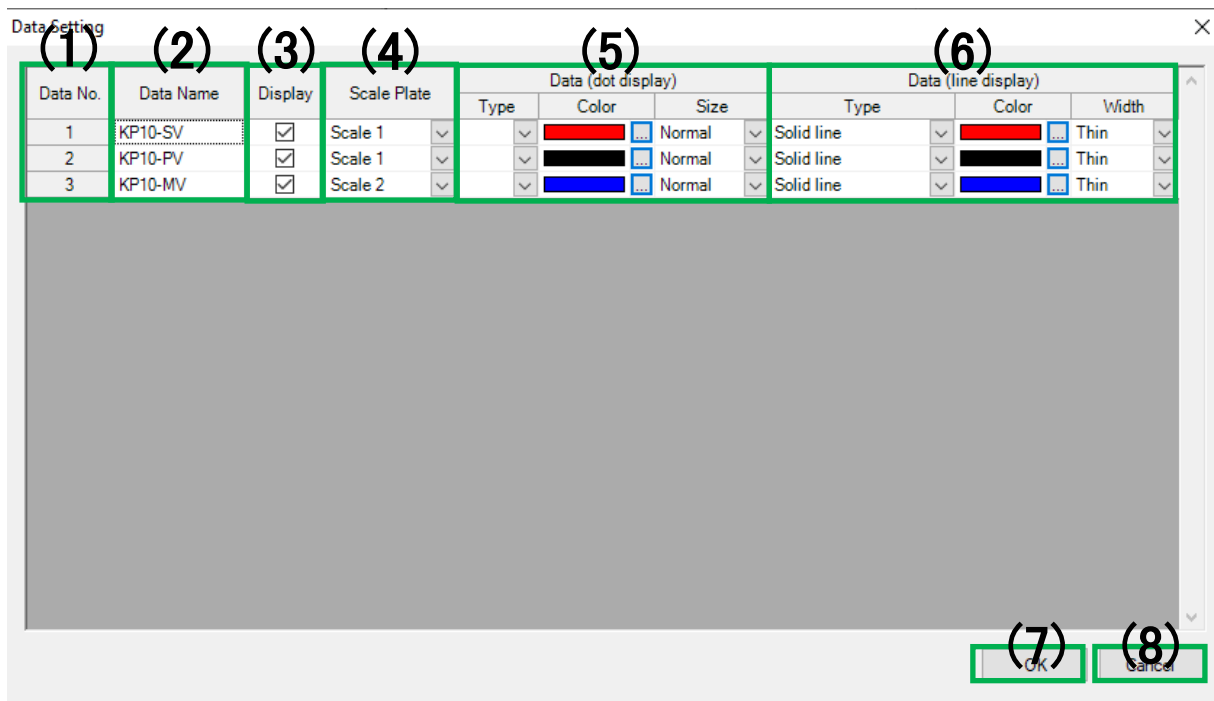

Num.	Name	Descriptions
(1)	Data No.	Displays data No. It can not be changed.
(2)	Data name	Displays data name. It can not be changed.
(3)	Display	Specify whether or not to display. *Check mark: displays, without check mark: do not display
(4)	Scale plate	Select and specify the scale plate to plot the data from scale 1 to scale 10.
(5)	Dot setting	Specify type, color and size of the dot to display data value. <b>[Type]</b> Select and specify from None (blank)/ □/ ■/ ◇/ ◆/ △/ ▲/ ×/ */ ○/ ●/ + . <b>[Color]</b> Specify from color dialog. <b>[Size]</b> Select and specify from Small/ Normal/ Large.
(6)	Line setting	Specify type, color and width of line to display data value. <b>[Type]</b> Select and specify from none (blank)/ solid line/ chain dash line/ wave line/ dash dotted line/ dash double dotted line. <b>[Color]</b> Specify from color dialog. <b>[Width]</b> Select and specify from Thin/ Normal/ Thick.
(7)	OK	Reflect setting contents to trend graph display window.
(8)	Cancel	Ignores setting information of data setting window and cancels reflecting setting contents.

## 13-7-2 Graph area setting window

Edits graph area.

### <Names of Parts on graph area setting window>

The window is displayed by following operation.

[TRAMS]→[Data acquisition]→[Trend display]→[Select applicable group from drop-down list]→[Graph area setting]

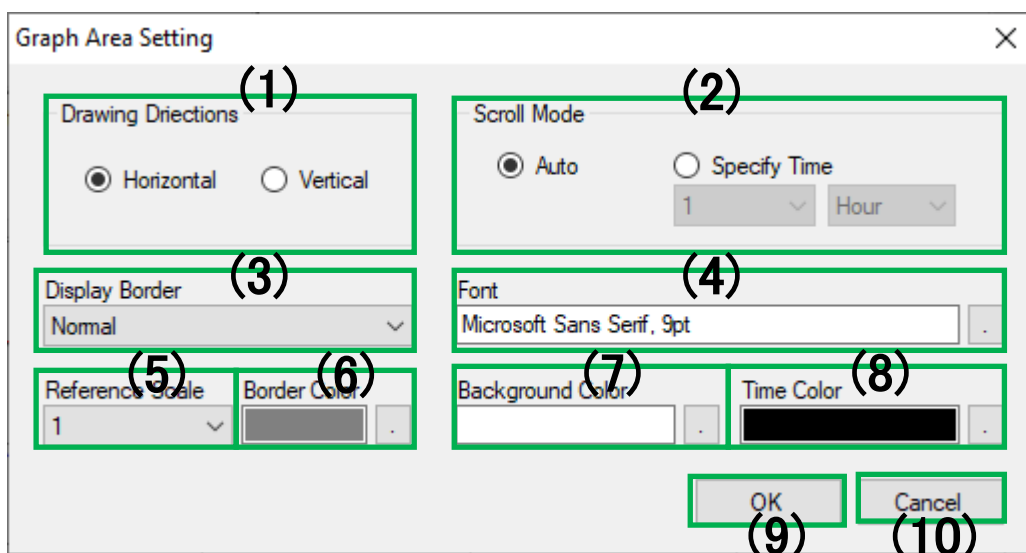

Num.	Name	Descriptions
(1)	Drawing direction	Select and specify graph scroll method form horizontal flow or vertical flow.
(2)	Scroll mode	Select and specify scroll method form auto or time specify. *If time specify is selected, select and specify display time width from 1 to 59min/ 1 to 24hr.
(3)	Ruled line display	Select and specify display type of ruled line from None/ Standard (displayed at the scale position)/ Detailed (displayed also at support scale position) / Detailed2 (displayed also in light colors at support scale position).
(4)	Font	Specify the font used at the graph area and time axis.
(5)	Reference scale	Select and specify scale plate for ruled line display from 1 to 10.
(6)	Ruled line color	Specify the color of ruled line.
(7)	Background color	Specify the background color of graph area.
(8)	Time color	Specify foreground color of time axis.
(9)	OK	Reflects setting contents to trend graph setting window.
(10)	Cancel	Ignores setting information and cancels reflecting setting contents.

### 13-7-3 Scale plate setting window

Edits scale plate setting of the trend graph.

#### <Names of Parts on scale plate setting window>

The window is displayed by following operation.

[TRAMS]→[Data acquisition]→[Trend display]→[Select applicable group from drop-down list]→[Scale plate setting]

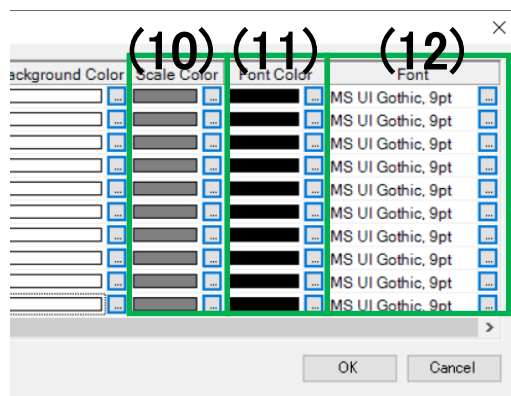
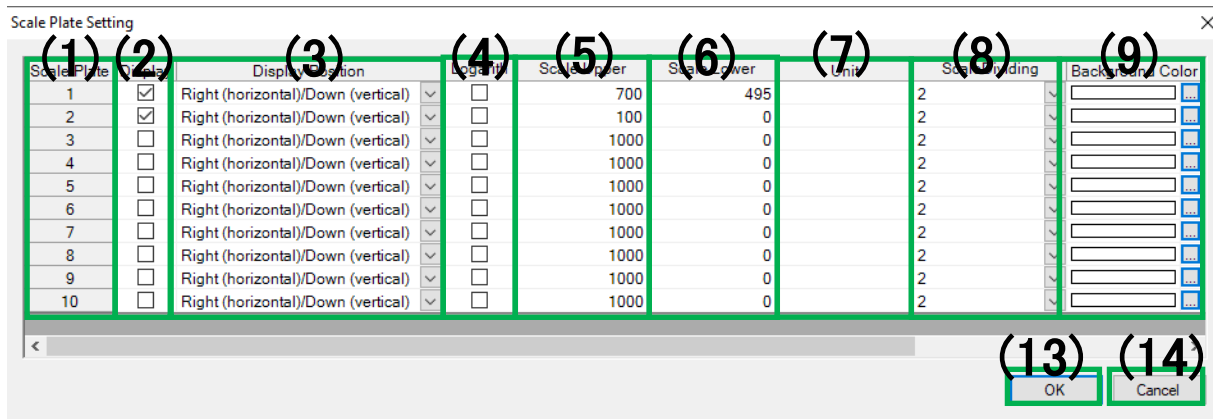

Num.	Name	Descriptions
(1)	Scale plate	Display 1 to 10 scale plate number. It can not be changed.
(2)	Display	Specify whether or not to display. *With check mark: displays, without check mark: not display
(3)	Display position	Select and specify scale plate display position from left (horizontal) or top (vertical)/ right (horizontal) or bottom (vertical). *By changing setting of Drawing direction of 13-7-2. Graph area setting window, left/ top or right/ bottom is changed automatically. *(Horizontal) means drawing direction horizontal flow and (Vertical) means drawing direction vertical flow.
(4)	Logarithm	Select and specify expression of scale value from normal or logarithm. *With check mark: logarithm, without check mark: normal
(5)	Scale upper	Specify scale plate higher limit value from -99999.999 to 99999.999. *For logarithm scale, it is exponential format. Initial value: 1000
(6)	Scale lower	Specify scale plate lower limit value from -99999.999 to 99999.999. *For logarithm scale, it is exponential format. Initial value: 0
(7)	Unit	Specify the unit to display on the scale plate. Up to 10 letters can be input.
(8)	Scale dividing	Select and specify number of scale line divisions from 2/ 3/ 4/ 5/ 6/ 7/ 8/ 9/ 10/ 11/ 12/ 13/ 14/ 15/ 16/ 17/ 18/ 19/ 20.

		This scale division is to control number of support scale lines which divide between main scales automatically assigned by scale higher/ lower limits (so depending on scale higher/lower limits setting, it may not be the divided number. *For logarithm scale, it is fixed to 9.
(9)	Background color	Specify the background color of scale plate.
(10)	Scale plate color	Specify the color of scale lines.
(11)	Font color	Specify the foreground color of scale value.
(12)	Font	Specify the font of scale value.
(13)	OK	Holds setting information and reflects setting contents to trend graph display window.
(14)	Cancel	Ignores setting information and cancels reflecting setting contents to trend graph display window

\*The number of scale plate is extended from 4 to 10. (Function from TRAMS v4.0.2.0)

◆ 13-7-3-1. Operation of scale plate area

(1) Data value reference scale is set at 13-7-1. Data setting window.

(2) Scale range can be enlarged by using mouse and drag scale plate display area. Enlarged scale turns back to initial state by right click. Enlargement of the scale area is available of by specifying the scale plate display area using a mouse and drag. The enlarged scale is return to the initial size by right-click and choosing “Cancel scale enlargement(E)”.

(3) By clicking each scale, only the data assigned to the scale is displayed. All the data is displayed by scale right-click and choosing “Cancel data display of the selected scale(V)”.

(4) By using mouse and drag scale plate display frame to specify the range, scale plate display size can be changed.

Reference scale of each data is set at data setting window.

(1)

(2)

(3)

(4)

By dragging display area of scale plate, width of the scale plate changes.

By dragging this vertical line, width of the scale plate changes.

Data No.	Data Name	Display	Scale Plate	Data (dot display)			Data (line display)		
				Type	Color	Size	Type	Color	Width
1	DB10-SV	<input checked="" type="checkbox"/>	Scale 1		Red	Normal	Solid line	Red	Normal
2	DB10-PV	<input checked="" type="checkbox"/>	Scale 1		Blue	Normal	Solid line	Blue	Normal
3	DB10-MV	<input checked="" type="checkbox"/>	Scale 1		Green	Normal	Solid line	Green	Thin
4	LT23-SP	<input checked="" type="checkbox"/>	Scale 2		Blue	Normal	Solid line	Blue	Thin
5	LT23-PV	<input checked="" type="checkbox"/>	Scale 2		Red	Normal	Solid line	Red	Thin
6	LT23-MV	<input checked="" type="checkbox"/>	Scale 2		Green	Normal	Solid line	Green	Thin
7	DI50-PV	<input checked="" type="checkbox"/>	Scale 3		Blue	Normal	Solid line	Blue	Thin
8	DI50-MAX	<input checked="" type="checkbox"/>	Scale 3		Red	Normal	Solid line	Red	Thin
9	DI50-MIN	<input checked="" type="checkbox"/>	Scale 3		Blue	Normal	Solid line	Blue	Thin
10	DB20-SV	<input checked="" type="checkbox"/>	Scale 4		Green	Normal	Solid line	Green	Thin
11	DB20-PV	<input checked="" type="checkbox"/>	Scale 4		Blue	Normal	Solid line	Blue	Thin
12	DB20-MV	<input checked="" type="checkbox"/>	Scale 4		Red	Normal	Solid line	Red	Thin
13	KP10-SV	<input checked="" type="checkbox"/>	Scale 10		Blue	Normal	Solid line	Blue	Thin
14	KP10-PV	<input checked="" type="checkbox"/>	Scale 10		Red	Normal	Solid line	Red	Thin
15	KP10-MV	<input checked="" type="checkbox"/>	Scale 10		Green	Normal	Solid line	Green	Thin

Pop-up menu when the scale is right-clicked:

If the “Cancel all(A)” is clicked, it cancels both “Cancel scale enlargement(E)” and “Cancel data display of the selected scale(V)”.

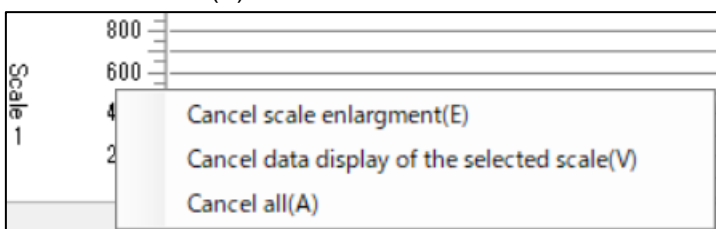

### 13-7-4 Numeric data setting window

Edits numeric data setting.

#### <Names of Parts on numeric data setting window>

The window is displayed by following operation.

[TRAMS]→[Data acquisition]→[Trend display]→[Select applicable group from drop-down list]→[legend setting]

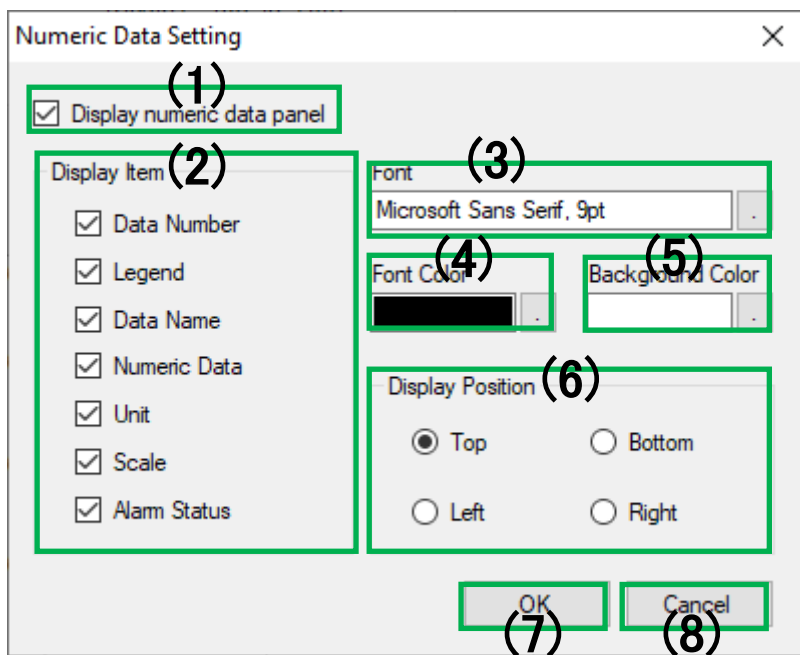

Num.	Name	Descriptions
(1)	Display numeric data panel	Specify whether or not to display numeric data. *With check mark: displays, without check mark: not display
(2)	Display item	Specify whether or not to display items of numeric data. *With check mark: displays, without check mark: not display
(3)	Font	Specify font information of numeric data.
(4)	Font color	Specify foreground color of numeric data.
(5)	Background color	Specify background color of numeric data.
(6)	Display position	Select and specify numeric data display position from top/ bottom/ left/ right.
(7)	OK	Reflect setting contents.
(8)	Cancel	Ignores setting information and cancels reflecting setting contents.



### 13-7-5 Operation setting window

Perform operation setting to the \*controller. (Setting for recorder can not be done.)

\*This does not support DP-G, LT23A, LT35A/ 37A and LT45A/47A.

#### <Names of Parts on numeric data setting window>

The window is displayed by following operation.

[TRAMS]→[Data acquisition]→[Trend display]→[Select applicable group from drop-down list]→[Operation setting]

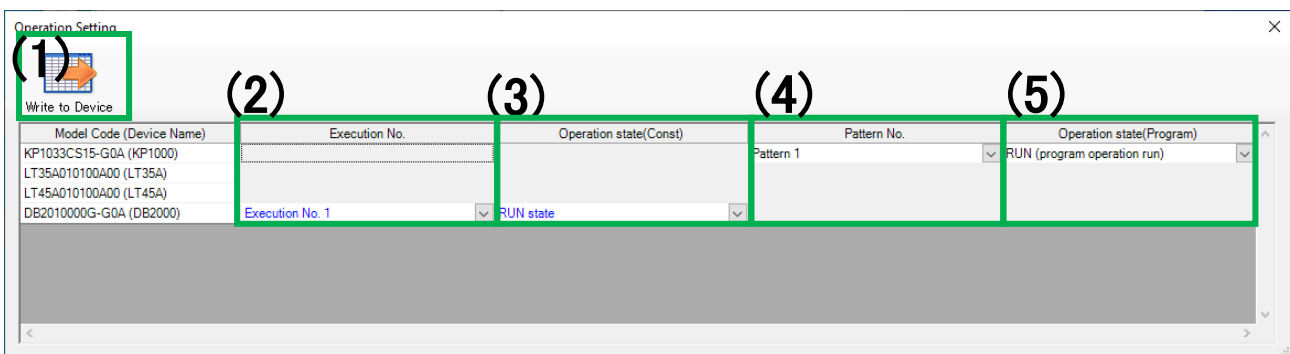
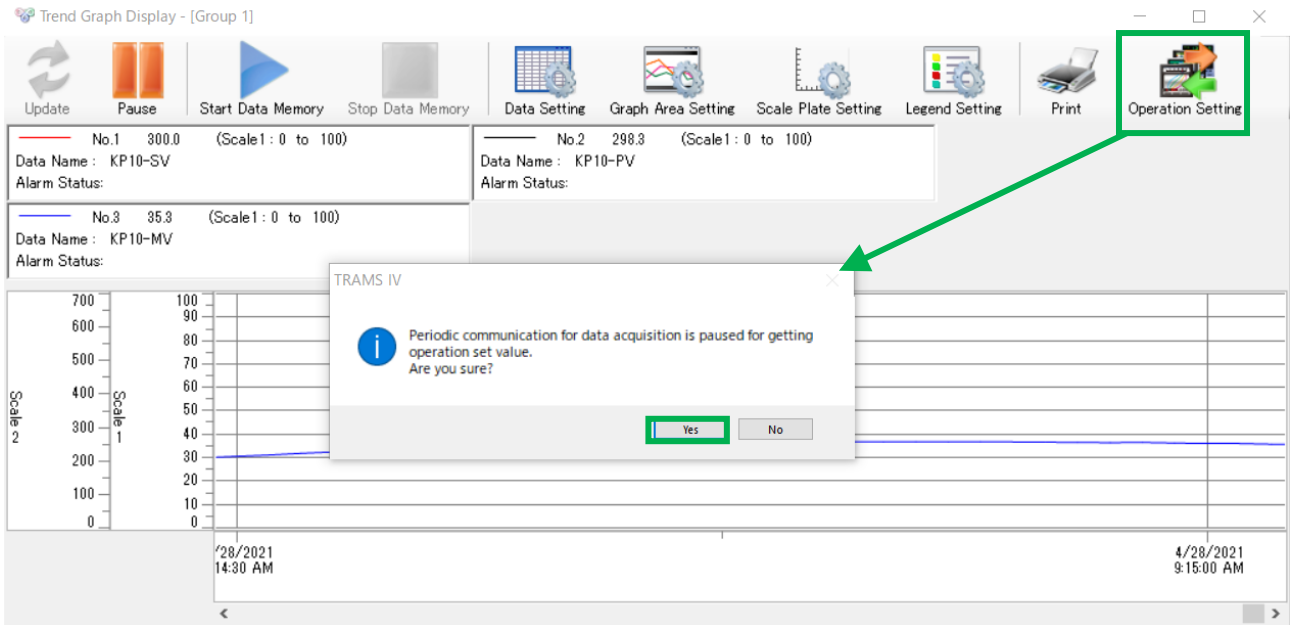

Num.	Name	Descriptions
(1)	Write to device	Load operation setting to device. At loading, regular communication for data acquisition is paused.
(2)	Execution No. (Constant value operation)	Changes Execution No. It can be set while constant value operation is running. (The display is grayed out at program operation.)
(3)	Operation status (Constant value operation)	Switches RUN/ READY of the controller. It can be set while constant value operation is running. (The display is grayed out at program operation.)
(4)	Pattern No. (Program operation)	Changes pattern No. It can be set to the device supporting the program operation and when it is on the program operation. (The display is grayed out at constant value operation.)
(5)	Operation status (Program operation)	Switches operation status of the controller. It can be set to the device supporting the program operation and when it is on the program operation. (The display is grayed out at constant value operation.)



## Caution

**If parameter reading or writing is done while data acquisition, data acquisition communication stops. So, stop data memory operation and perform parameter writing.**

## 13-8 Real-time data list display window

It updates and displays list of acquiring data included in the selected acquiring group in real-time.

### <Names of Parts on real-time data list display window>

The window is displayed by following operation.

[TRAMS]→[Data acquisition]→[Data display]→[Select applicable group from drop-down list]

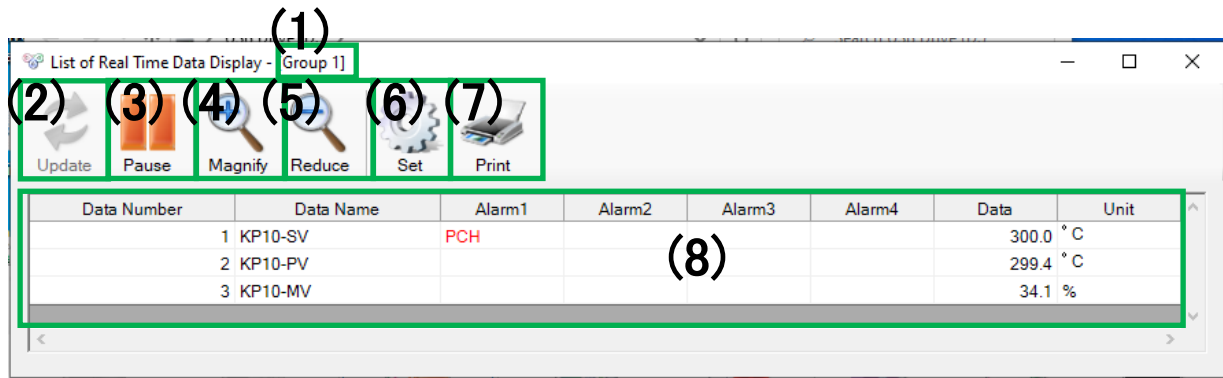

Num.	Name	Descriptions	Reference
(1)	Acquiring group name	Displays display name of selected acquiring group.	
(2)	Update	Resumes update when data list update is paused. *At update/pause, valid/ invalid of the buttons are switched.	
(3)	Pause	Pauses update when data list is updating. *At update/pause, valid/ invalid of the buttons are switched.	
(4)	Increase	Increases font size of list display. *Enlarge up to twice the standard value.	
(5)	Reduce	Reduces font size of list display. *Reduces up to 0.5 times the standard value.	
(6)	Set	Displays display setting window of real-time data list. *Double-clicking on (8) Real-time data list display works as same.	13-8-1
(7)	Print	Print out data list in display. *Displays print preview.	
(8)	Real-time data list display	Displays the list of acquiring data information included in the subject acquiring group in real-time. *If normal data acquisition can not be done due to communication error etc., [Invalid] is displayed in the data column. If model code of communication subject device differs from that of specified in TRAMS etc. Or communication can not be continued, data acquisition is skipped and it display s blank (no data).	

### 13-8-1 Display setting window

It changes display setting of real-time data list.

#### <Names of Parts on display setting window>

The window is displayed by following operation.

[TRAMS]→[Data acquisition]→[Data display]→[Select applicable group from drop-down list]→[Setting]

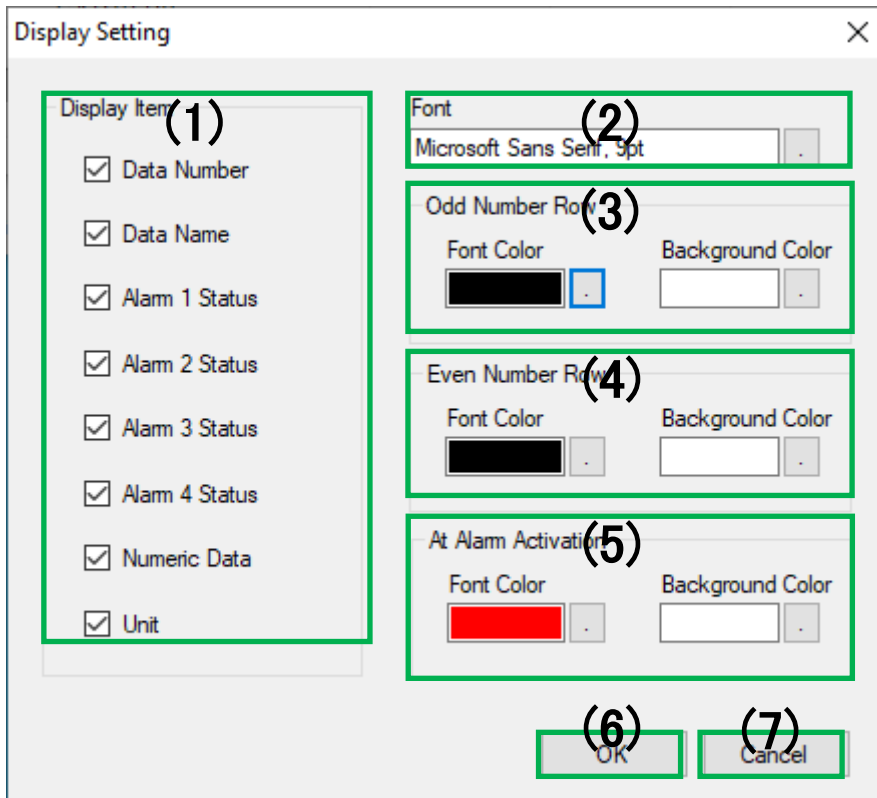

Num.	Name	Descriptions
(1)	Display items	Specifies whether or not to display items on a row on real-time data list. *With check mark: displays, without check mark: not display.
(2)	Font	Specifies font information of real-time data list display window.
(3)	Odd number row Cell setting	Specifies font color and background color of odd number cells on real-time data list display window.
(4)	Even number row Cell setting	Specifies font color and background color of even number cells on real-time data list display window.
(5)	Alarm activation Cell setting	Specifies font color and background color of alarm activated cell on real-time data list display window.
(6)	OK	Holds setting information and reflects setting contents to real-time data list display window.
(7)	Cancel	Ignores setting information and cancels reflecting setting contents to real-time data list display window.

## 14 Data analysis

In data analysis, it opens and displays analysis data file recorded by TRAMS data acquisition, acquired data file recorded by devices and analysis file saved by data analysis function.

### <Names of Parts on launcher data analysis>

The window is displayed by following operation.

[TRAMS]→[Data analysis]

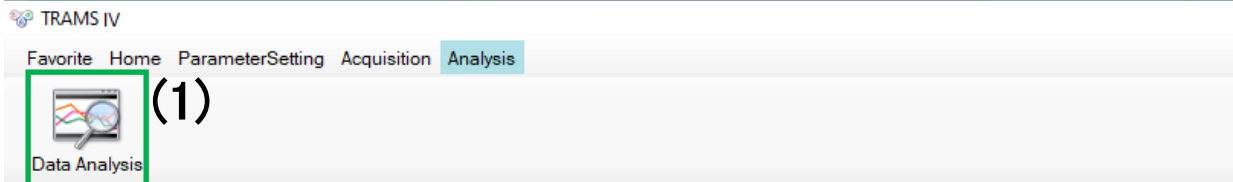

Num.	Name	Descriptions	Reference
(1)	Data analysis	<ul style="list-style-type: none"> <li>· File open dialog is displayed for searching acquired data file.</li> <li>· Using specified data file, it displays data analysis window.</li> <li>· Following extension files can be selected.               <ul style="list-style-type: none"> <li>-*.dmf file (Acquired data file)</li> <li>-*.zil file (Data analysis file)</li> <li>-*.a4f file (File recorded by AL4000/ AH4000)</li> <li>-*.krf file (File recorded by KR series)</li> <li>-*.kpf file (File recorded by KR Heat Treatment Assistance Spec.)</li> <li>-*.I5f file (Files recorded by LE5100 and 5200)</li> </ul> </li> <li>· It does not support files created by CHINO software KIDS and ZAILA.</li> <li>· Acquired data files can be connected. Connect the files by following methods.               <ul style="list-style-type: none"> <li>-By selecting multiple files while displaying file open dialog.</li> <li>-Connecting by clicking Connect to previous file. Connect to following file or Connect all files buttons.</li> <li>-Open connecting file list window and connect by marking the files.</li> </ul> </li> </ul> <p>Files can be connected is *.dmf file, *.a4f file, *.krf file, *.kpf file and *.I5f file. *.zil file (Data analysis file) can not be connected.</p>	14-1

### Caution

For connecting acquired data files

Acquired data file can be connected. However, following condition is required.

- **Acquired data file intended to connect is same extension (\*.dmf, \*.a4f, \*.krf, \*.kpf or \*.I5f files).**
- **Contents of acquired data file intended to connect are following**
  - Data memory intervals are the same
  - Number of the data is the same
  - Group name is the same (Only for \*.dmf)
  - CH number is the same (Only for \*.a4f, \*.krf, \*.kpf or \*.I5f)

\*.zil file (Data analysis file) can not be connected.

\*For condition setting, refer to 13-3-1. Group edit window and 13-6. Data memory operation window.

If multiple acquired data files are selected, but these does not satisfy connection conditions, these are not connected and displayed in another windows.

# 14-1 Data analysis window

It opens, displays and analyzes information of data acquired by TRAMS, data acquired by devices or analysis file saved by data analysis function.

### <Names of Parts on data analysis window>

The window is displayed by following operation.

[TRAMS]→[Data analysis]→[Data analysis]→[Open after file selection]

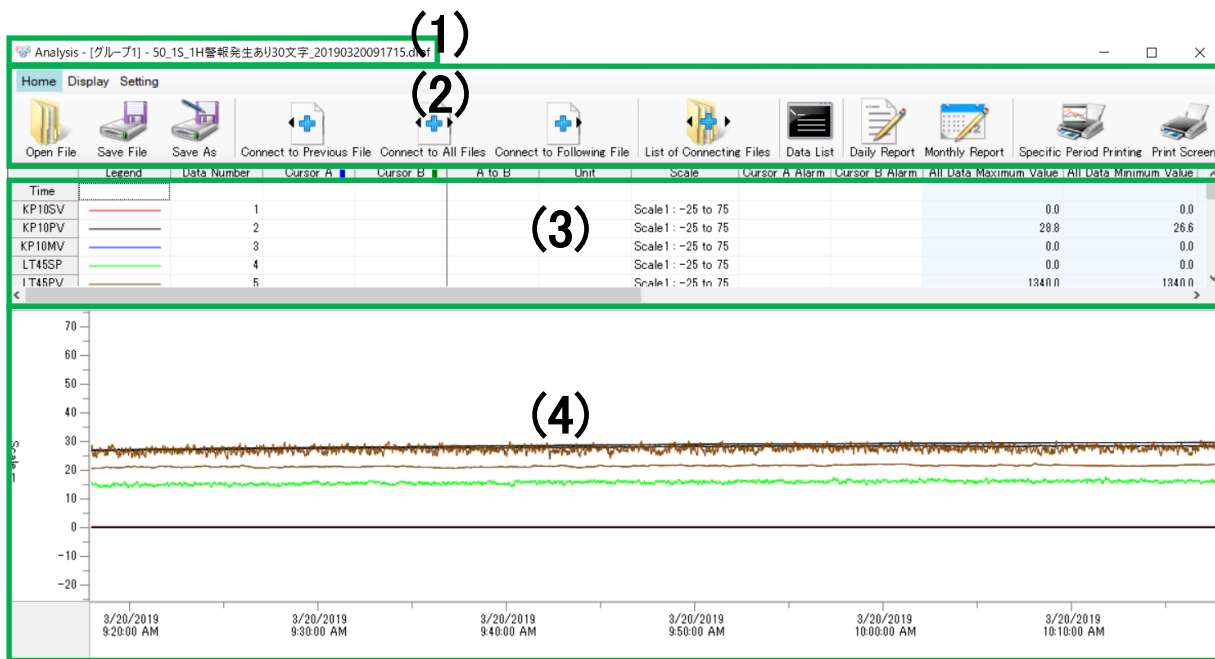

Num.	Name	Descriptions	Reference
(1)	Data analysis window Title	Displays in the order of data analysis-[File title property]-file name. *Default of file title is group name of currently opened data.	
(2)	Toolbar	Execute various functions on data analysis window.	14-2 to 14-5
(3)	Numeric data/ Bar graph display	Data links to a cursor on the trend graph is displayed. Following three types of data are displayed · Numeric data...Displays numeric data of cursor A and B. It also displays time, time difference and data difference. · Bar graph...Displays bar graph of cursor A and B next to each other. · Stacked graph... Displays data of cursor A and B in one bar as overlay graph. *Graph drawing color is set by [TRAMS]→[Data analysis]→[Data analysis]→[Open after file selection]→[Setting]→[Data setting]	14-6
(4)	Trend graph display	Displays acquired data in the data file in a graph.	14-7

## 14-2 Toolbar

It displays tool buttons for starting up and executing functions of data analysis window.

### <Operation flow of the toolbar>

1. Startup data analysis window

When data analysis window is started and displayed, it is displayed as [Home] menu.



2. Select a function

Toolbar can be broadly divided into three function selections.

From left of the menu bar, it is [Home], [Display] and [Setting].

By clicking each menu button, tool buttons underneath switches to corresponding functions.

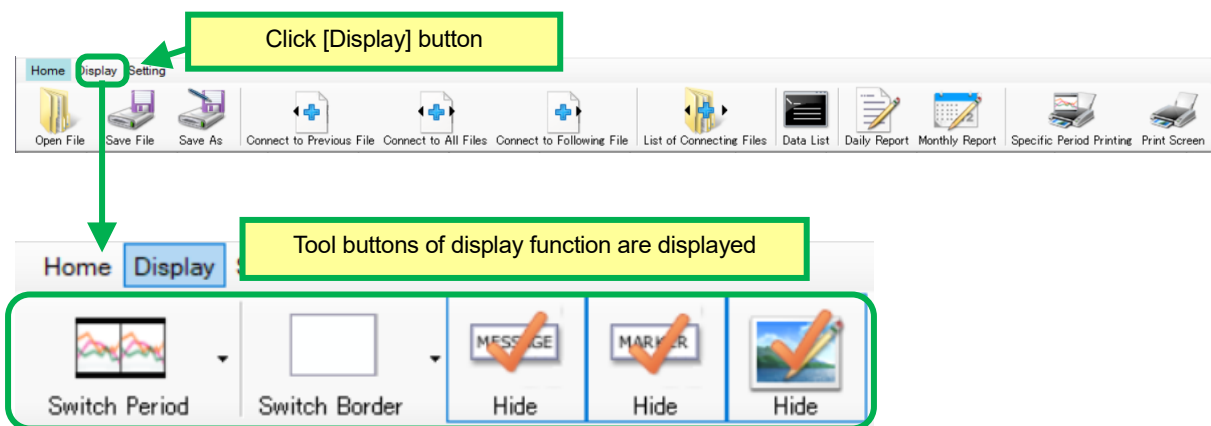

### 3. Starting up each function

After selecting function as in 2. Click a tool button in the lower tool button.  
By clicking tool button, corresponding function/ window can be startup.

Click data list display button

Corresponding window of clicked tool button is displayed or function is executed.

Time	db65sv	dv65pv	db65mv	db2sv	db2pv
2018/10/30 10:46:38.00	0.0	Over.R	0.0	29.1	29.1
2018/10/30 10:46:39.00	0.0	Over.R	0.0	29.1	29.1
2018/10/30 10:46:40.00	0.0	Over.R	0.0	29.1	29.1
2018/10/30 10:46:41.00	0.0	Over.R	0.0	29.1	29.1
2018/10/30 10:46:42.00	0.0	Over.R	0.0	29.1	29.1
2018/10/30 10:46:53.00	0.0	Over.R	0.0	29.1	29.1
2018/10/30 10:46:54.00	0.0	Over.R	0.0	29.1	29.1
2018/10/30 10:46:55.00	0.0	Over.R	0.0	29.1	29.1
2018/10/30 10:46:56.00	0.0	Over.R	0.0	29.1	29.1
2018/10/30 10:46:57.00	0.0	Over.R	0.0	29.1	29.1
2018/10/30 10:46:58.00	0.0	Over.R	0.0	29.1	29.1
2018/10/30 10:46:59.00	0.0	Over.R	0.0	29.1	29.1
2018/10/30 10:47:00.00	0.0	Over.R	0.0	29.1	29.1
2018/10/30 10:47:01.00	0.0	Over.R	0.0	29.1	29.1
2018/10/30 10:47:02.00	0.0	Over.R	0.0	29.1	29.1
2018/10/30 10:47:03.00	0.0	Over.R	0.0	29.1	29.1
2018/10/30 10:47:04.00	0.0	Over.R	0.0	29.1	29.1
2018/10/30 10:47:05.00	0.0	Over.R	0.0	29.1	29.1
2018/10/30 10:47:06.00	0.0	Over.R	0.0	29.1	29.1
2018/10/30 10:47:07.00	0.0	Over.R	0.0	29.1	29.1



## 14-3 Operation of home

### <Names of Parts on Home of toolbar>

The window is displayed by following operation.

[TRAMS]→[Data analysis]→[Data analysis]→[Open after file selection]→[Home]

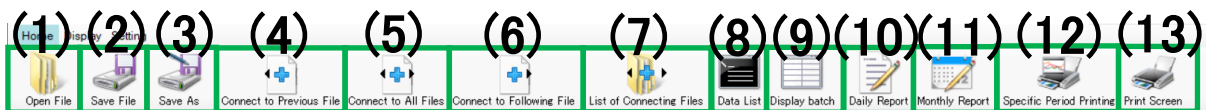

Num.	Name	Descriptions	Reference
(1)	Open file	<ul style="list-style-type: none"> <li>· Displays file open dialog</li> <li>· Specified data file is opened and displayed on the data analysis window.</li> <li>*Following extension files can be selected.</li> <li>-*.dmf file -*.zil file</li> <li>-*.a4f file (File recorded by AL4000/ AH4000)</li> <li>-*.krf file (Files recorded by KR series and SC5000)</li> <li>-*.kpf file (File recorded by KR Heat Treatment Assistance Spec.)</li> <li>-*.l5f file (Files recorded by LE5100 and 5200)</li> <li>*Connectable data are connected to original data and opened and displayed. For other cases, another window startups and then opened and displayed.</li> <li>(For connecting acquired data files, refer to Caution of 14. Data analysis)</li> <li>*If window to display exceeds specified number of displayable window, it can not be started up.</li> <li>(For specified number of window to display, refer to 4-1. Flow of operation)</li> <li>*It does not support files created by CHINO software KIDS and ZAILA.</li> <li>*Loading krf file recorded by SC5000is a function from TRAMS III version 3.0.0.7.</li> </ul>	
(2)	Save file	<p>Saves analysis data file.</p> <p>*For the file saved by zil format, it is saved as overwritten, if it is not the case, the file is saved as Save as (*.zil file).</p>	
(3)	Save as	Specify a folder, it names and saves file (*.zil file).	
(4)	Connect to previous file	Connect to a previous file in the same hierarchy as currently opened file. *	14-3-5
(5)	Connect all files	Connect to all the files in the same hierarchy as currently opened file. *	14-3-5
(6)	Connect to following file	Connect to a subsequent file in the same hierarchy as currently opened file. *	14-3-5
(7)	List of connection file	Displays a list of files available to connect and connect to a selected file or cancels the connection.	14-3-6
(8)	Data list	Displays data list display window.	14-3-1
(9)	Batch display	Displays batch information of KR binary data file (.krf, .kpf). (This button is displayed only if batch information is included in the KR binary data file when it opened.)	14-3-7
(10)	Daily report output	Output daily report by specifying the output condition.	14-3-2
(11)	Monthly report output	Output monthly report by specifying the output condition.	14-3-3
(12)	Specific period printing	Print out trend graph by specifying the subject period.	14-3-4
(13)	Print screen	Print out a current screen view. Displays a print preview.	

\*If reference folder in a list of connection file is already changed and connected, it connects to a file in the hierarchy.

### 14-3-1 Data list display window

It displays data displayed in the trend graph on the data analysis window as a list of numeric data.

#### <Names of Parts on data list display window >

The window is displayed by following operation.

[TRAMS]→[Data analysis]→[Data analysis]→[Open after file selection]→[Home]→[Data list]

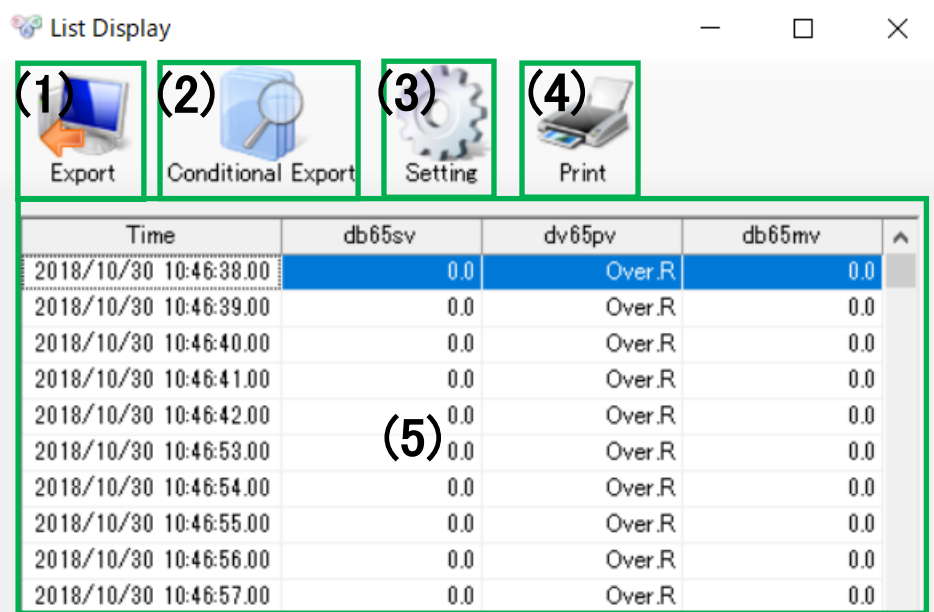

Num.	Name	Descriptions	Reference
(1)	Export	Select file format from · CSV (Comma separated), · Text (Tab separated), · Excel (xlsx), specify output destination and output a file. *Only for the Excel (xlsx) format, a graph is added.	
(2)	Conditioned extraction	Displays extraction window.	14-3-1-1
(3)	Setting	Displays display setting window.	14-3-1-2
(4)	Print	Prints out displaying data list. *Displays print preview. *Font changed at (3) Setting is not apply to printing.	
(5)	Data list display	Displays a list of acquired time and acquired value of subject data. *By double-clicking on the data list display area, a list cursor is displayed on Trend graph display area. For more details, refer to 14-7 Trend graph display area (2) List cursor.	

◆ 14-3-1-1. Extraction window

It extracts subject data from data list display window by specifying condition.

< Names of Parts on Extraction window (after expanding detailed conditions)>

The window is displayed by following operation.

[TRAMS]→[Data analysis]→[Data analysis]→[Open after file selection]→[Home]→[Data list]→[Conditioned extraction]

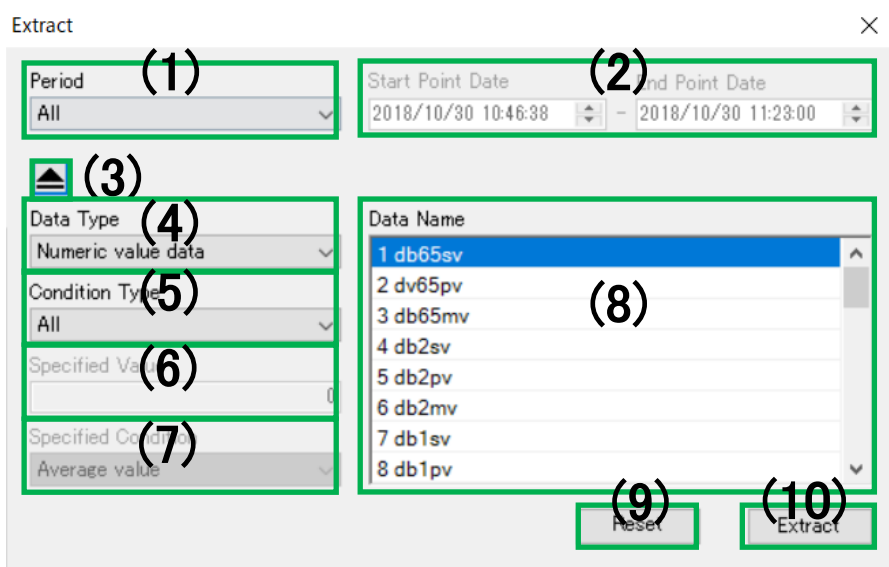

Num.	Name	Descriptions
(1)	Period	Select and specify period of extract condition from All/ Between AB cursors/ Display period/ Specific period.
(2)	Start/ End point date	This becomes valid if specific period is selected at extract condition period. Specify Start/ End date and time to decide the period.
(3)	Detailed condition expand button	Switches Display/ Not display detailed condition.
(4)	Data type	Select and specify extract data type from Numeric data/ Message/ Marker text/ All. *[All] is a function from TRAMS IV version 4.0.0.2.
(5)	Condition type	Select and specify the conditions for each type of data to be extracted from the following types. [Numeric data]···All/ Maximum value/ Minimum value/ Average value/ Standard deviation/ Median value/ Specified value/ Alarm activation [Message]···All/ Matches text string/ Contains text string/ Not contains text string [Marker text]···All/ Matches text string/ Contains text string/ Not contains text string
(6)	Specified value	It is valid if extract condition is other than [Numeric data + Specified value] or [Other than Message/ Marker text + All]. For numeric data, specify from -99999 to 99999. For Message/ Marker text, specify character string (Capital letter/Lower case letter and Double byte letter/ single-byte character are distinguished).

## Reference

For message and marker text display when [All] is selected at (4) Data type  
Depending on acquisition interval, multiple messages and marker texts may  
displayed in a row. If file is exported as CSV format as that state, messages and  
marker texts are added to right columns for that number.

Num.	Name	Descriptions
(7)	Specified condition	This becomes invalid if extract condition is [Numeric data + Average value/ Standard deviation/ Middle value/ Specified value/ Alarm activation]. Select and specify specific condition for each condition type from following. [Average value]···Average value/ Average value or more/ Average value or less [Standard deviation]···Standard deviation/ Standard deviation or more/ Standard deviation or less [Middle value]···Middle value/ Middle value or more/ Middle value or less [Specified value]···Specified value/ Specified value or more/ Specified value or less [Alarm activation]···Alarm activated/ Alarm 1 activated/ Alarm 2 activated/ Alarm 3 activated/ Alarm 4 activated
(8)	Data name	A list of the data names which is displayed on the trend graph by the data types is displayed. The extraction conditions are applied to the data selected here.
(9)	Condition reset	Returns changed extraction condition to the initial value.
(10)	Extract	Performs extract process of subjective data according to the specified condition.

## ◆ 14-3-1-2. Display setting window

It edits display setting of data list display window.

**<Names of Parts on Display setting window>**

The window is displayed by following operation.

[TRAMS]→[Data analysis]→[Data analysis]→[Open after file selection]→[Home]→[Data list]→[Setting]

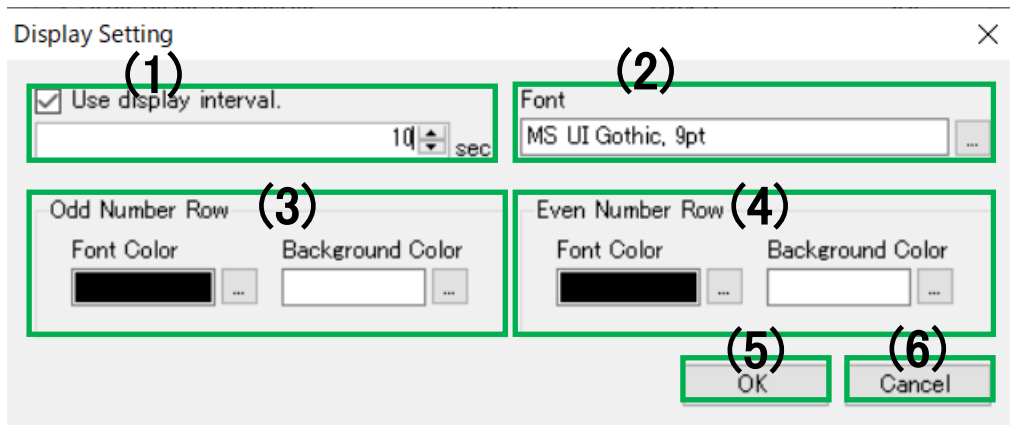

Num.	Name	Descriptions
(1)	Display interval setting area	Specify whether or not to use display interval to the data time displayed in a list and set value from 1 to 86400[sec]. Initial value: Without check mark, 1sec *According to display interval, data is displayed in data list window by specified interval. *It displays all data if value smaller than interval at data memory is set. *Setting contents are to be maintained for the next time display setting window is opened. (function from TRAMS III)
(2)	Font	Specify font information of data list display window. Initial value: MS UI Gothic, 9Pt *Setting contents are to be maintained for the next time display setting window is opened. (function from TRAMS III)
(3)	Odd number row setting area	Specify font color and background color of odd number cell of data list display window. Initial value: font color black, background color white *Setting contents are to be maintained for the next time display setting window is opened. (function from TRAMS III)
(4)	Even number roe setting area	Specify font color and background color of even number cell of data list display window. Initial value: font color black, background color white *Setting contents are to be maintained for the next time display setting window is opened. (function from TRAMS III)
(5)	OK	Holds setting information and reflects setting contents to data list display window.
(6)	Cancel	Ignores setting information and cancels reflecting setting contents to data list display window.

## 14-3-2 Daily report output window

Outputs data displayed in the trend graph on the data analysis window as daily report.

### <Names of Parts on Daily report output window>

The window is displayed by following operation.

[TRAMS]→[Data analysis]→[Data analysis]→[Open after file selection]→[Home]→[Daily report output]

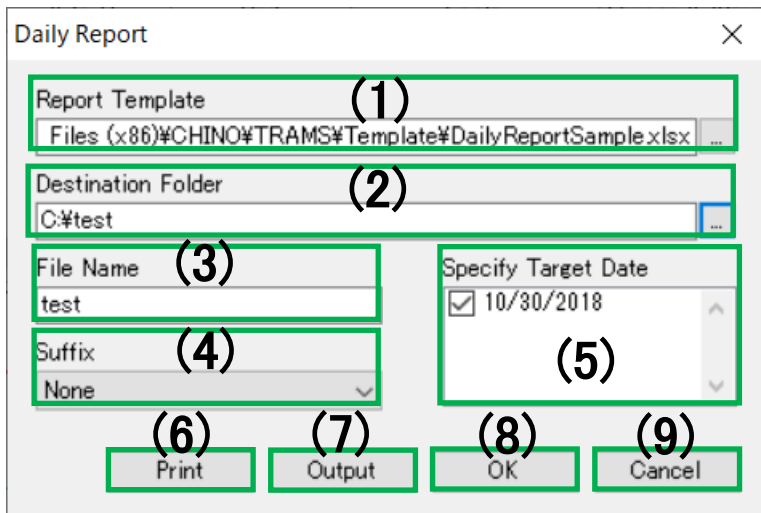

Num.	Name	Descriptions	Reference
(1)	Report template	Specify report template file, Excel (xlsx) using daily report function defined in TRAMS. Format of the daily report can specify at your discretion. *Sample of report template is stored in following location. C:¥Program Files (x86)¥CHINO¥TRAMS¥Template ¥DailyReportSample.xlsx(64bit) C:¥Program Files¥CHINO¥TRAMS¥Template ¥DailyReportSample.xlsx(32bit) *Setting contents are to be maintained for the next time display setting window is opened. (function from TRAMS III)	14-3-2-1
(2)	Output destination folder	Specify output destination folder used at daily report output. *Setting contents are to be maintained for the next time display setting window is opened. (function from TRAMS III)	
(3)	File name	Specify output file name used at daily report output. Initial value: (Blank) *Setting contents are to be maintained for the next time display setting window is opened. (function from TRAMS III)	
(4)	Suffix	Select and specify suffix to add to the end of the file at daily report output from None/ Sequential number/ Year Month Day. Initial value: None *If Date is selected from the selection, date specified at Subject date is used. *Setting contents are to be maintained for the next time display setting window is opened. (function from TRAMS III)	
(5)	Specify target date	Select date to print out or output. *To perform daily output by specifying multiple subject dates, it is required to set suffix other than None.	
(6)	Print	Print out daily report by specified conditions. *Displays print preview.	

Num.	Name	Descriptions	Reference
(7)	Output	Output daily report as a file by specified conditions.	
(8)	OK	Retains specified conditions and exits from the window.	
(9)	Cancel	Cancel specified conditions and exits from the window.	

## ◆ 14-3-2-1. Daily report function

Functions used in daily report template are shown below.

\*If result of specified function can not be obtained, (specified data does not exist etc.) [#Blank!], if use of function is wrong and unexpected error occurs, [#Error!] is displayed on the daily report.

Function name		Argument	
ReportTime	Input date of the report.		
GetData	Input instantaneous value (Data at specified time).	Required (int) Data No : Data number	
		Required (int) Hour : Time (hr)	
		Required (int) Minute : Time (min)	
		Required (int) Second : Time (sec)	
Max	Input max value.	Optional (int) Data No : Data number	
		Optional (int) Hour : Time (hr)	
Min	Input mini value.	Optional (int) Data No : Data number	
		Optional (int) Hour : Time (hr)	
Average	Input average value.	Optional (int) Data No : Data number	
		Optional (int) Hour : Time (hr)	
MaxTime	Input time when the max value is first detected.	Optional (int) Data No : Data number	
		Optional (int) Hour : Time (hr)	
MinTime	Input time when the mini value is first detected.	Optional (int) Data No : Data number	
		Optional (int) Hour : Time (hr)	
MaxName	Input data name of which the max value is first detected.	Optional (int) Hour : Time (hr)	
MinName	Input data name of which the mini value is first detected.	Optional (int) Hour : Time (hr)	



## &lt;Example of use of the function&gt;

ReportTime()	⇒ [Excel output result]	2015/1/1
GetData(DataNo=1,Hour=13,Minute=30,Second=30)	⇒ [Excel output result]	150.05
Max()	⇒ [Excel output result]	500.00
		*Output MAX value of data of the daily report
Max(DataNo=1)	⇒ [Excel output result]	350.00
		*Output MAX value of corresponding data number (e.g. data number 1) in the daily report data.
Max(Hour=15)	⇒ [Excel output result]	300.00
		*Output MAX value of corresponding time period (e.g. 15:00 to 16:00) in the daily report data regardless of data number
Max(DataNo=1,Hour=15)	⇒ [Excel output result]	300.00
		*Output MAX value of corresponding data number corresponding time period (e.g. data number 1, 15:00 to 16:00) in the daily report data.

●The data output conditions can be changed as well, by setting the arguments below.

Min()	⇒ [Excel output result]	-50.00
Min(DataNo=1)	⇒ [Excel output result]	-45.00
Min(Hour=15)	⇒ [Excel output result]	-30.00
Min(DataNo=1,Hour=15)	⇒ [Excel output result]	-30.00
Average()	⇒ [Excel output result]	216.18
Average (DataNo=1)	⇒ [Excel output result]	180.39
Average (Hour=15)	⇒ [Excel output result]	230.52
Average (DataNo=1,Hour=15)	⇒ [Excel output result]	290.00
MaxTime()	⇒ [Excel output result]	2015/1/1 14:50:56
MaxTime (DataNo=1)	⇒ [Excel output result]	2015/1/1 14:50:56
MaxTime (Hour=15)	⇒ [Excel output result]	2015/1/1 15:30:48
MaxTime (DataNo=1,Hour=15)	⇒ [Excel output result]	2015/1/1 15:30:48
MinTime()	⇒ [Excel output result]	2015/1/1 10:16:12
MinTime (DataNo=1)	⇒ [Excel output result]	2015/1/1 10:16:12
MinTime (Hour=15)	⇒ [Excel output result]	2015/1/1 15:59:59
MinTime (DataNo=1,Hour=15)	⇒ [Excel output result]	2015/1/1 15:59:59
MaxName()	⇒ [Excel output result]	DB600_PV_001
MaxName(Hour=15)	⇒ [Excel output result]	DB600_PV_001
MinName()	⇒ [Excel output result]	DB600_PV_001
MinName(Hour=15)	⇒ [Excel output result]	DB600_PV_001

◆ 14-3-2-2. Daily report sample

Daily report template is stored in next location. Copy it to the other location and use.

(Pay attention not to delete the template.)

C:\Program Files (x86)\CHINO\TRAMS\Template\DailyReportSample.xlsx (for 64-bit)

C:\Program Files\CHINO\TRAMS\Template\DailyReportSample.xlsx (for 32 bit)

If output daily report using the sample, following report is created. Design and layout can be arranged by Excel.

Daily Report Sample										
December 26, 2020										
TIME	DATA1	DATA2	DATA3	DATA4	DATA5	DATA6	DATA7	DATA8	DATA9	DATA10
0:00:00	230.5	21.5	100	50.1	22.183	50.3	0	25.42	0	60
1:00:00	230.6	21.1	100	50.1	21.748	50.3	0	24.95	0	60
2:00:00	230.7	20.6	100	50.1	21.327	50.3	0	24.59	0.1	60
3:00:00	230.5	21.5	100	50.1	22.183	50.3	0	25.42	0	60
4:00:00	230.6	21.1	100	50.1	21.748	50.3	0	24.95	0	60
5:00:00	230.7	20.6	100	50.1	21.327	50.3	0	24.59	0.1	60
6:00:00	230.8	20.4	100	50.1	21.031	50.3	0	24.24	0	60
7:00:00	230.9	20.1	100	50.1	20.773	50.3	0	23.99	0	60
8:00:00	231	20	100	50.1	20.703	50.3	0	23.96	0	60
9:00:00	230.5	21.5	100	50.1	22.183	50.3	0	25.42	0	60
10:00:00	230.6	21.1	100	50.1	21.748	50.3	0	24.95	0	60
11:00:00	230.7	20.6	100	50.1	21.327	50.3	0	24.59	0.1	60
12:00:00	230.8	20.4	100	50.1	21.031	50.3	0	24.24	0	60
13:00:00	230.9	20.1	100	50.1	20.773	50.3	0	23.99	0	60
14:00:00	231	20	100	50.1	20.703	50.3	0	23.96	0	60
15:00:00	230.5	21.5	100	50.1	22.183	50.3	0	25.42	0	60
16:00:00	230.6	21.1	100	50.1	21.748	50.3	0	24.95	0	60
17:00:00	230.7	20.6	100	50.1	21.327	50.3	0	24.59	0.1	60
18:00:00	230.8	20.4	100	50.1	21.031	50.3	0	24.24	0	60
19:00:00	230.9	20.1	100	50.1	20.773	50.3	0	23.99	0	60
20:00:00	231	20	100	50.1	20.703	50.3	0	23.96	0	60
21:00:00	230.8	20.4	100	50.1	21.031	50.3	0	24.24	0	60
22:00:00	230.9	20.1	100	50.1	20.773	50.3	0	23.99	0	60
23:00:00	231	20	100	50.1	20.703	50.3	0	23.96	0	60
Max. value	231	21.7	100	50.1	22.471	50.3	0	25.66	0.4	60
Max. value detection time	7:45	2:27	2:27	2:27	2:28	2:27	2:27	2:27	3:44	2:27
Min. value	230.5	19.8	100	50.1	20.616	50.3	0	23.9	0	60
Min. value detection time	2:27	7:33	2:27	2:27	7:47	2:27	2:27	7:50	2:27	2:27
Ave. value	230.738	20.6238	100	50.1	21.328	50.3	0	24.5557	0.03178	60



## Caution

### For cell format

In the function, when numeric data is acquired, there is another function that obtains date and time. Change cell format depending on the contents of the function. Pay attention that if format is not applicable, error may occur.

### 14-3-3 Monthly report output window

Outputs data displayed in the trend graph on the data analysis window as monthly report.

#### <Names of Parts on Monthly report output window>

The window is displayed by following operation.

[TRAMS]→[Data analysis]→[Data analysis]→[Open after file selection]→[Home]→[Monthly report output]

Num.	Name	Descriptions	Reference
(1)	Report template	Specify report template file, Excel (xlsx) using monthly report function defined in TRAMS. Format of the monthly report can specify at your discretion. *Sample of report template is stored in following location. C:\Program Files (x86)\CHINO\TRAMS\Template\MonthlyReportSample.xlsx(64bit) C:\Program Files\CHINO\TRAMS\Template\MonthlyReportSample.xlsx(32bit) *Setting contents are to be maintained for the next time display setting window is opened. (function from TRAMS III)	14-3-3-1
(2)	Destination folder	Specify output destination folder used at monthly report output. *Setting contents are to be maintained for the next time display setting window is opened. (function from TRAMS III)	
(3)	File name	Specify output file name used at monthly report output. Initial value: (Blank) *Setting contents are to be maintained for the next time display setting window is opened. (function from TRAMS III)	
(4)	Suffix	Select and specify suffix to add to the end of the file at monthly report output from None/ Sequential number/ Year Month. Initial value: None *If Date is selected from the selection, date specified at Subject date is used. *Setting contents are to be maintained for the next time display setting window is opened. (function from TRAMS III)	
(5)	Specify target date	Select month to print out or output. *To perform monthly output by specifying multiple subject months, it is required to set suffix other than None.	
(6)	Print	Print out monthly report by specified conditions. *Displays print preview.	

Num.	Name	Descriptions	Reference
(7)	Output	Output monthly report as a file by specified conditions.	
(8)	OK	Retains specified conditions and exits from the window.	
(9)	Cancel	Cancel specified conditions and exits from the window.	

## ◆ 14-3-3-1. Monthly report function

Functions used in monthly report template are shown below.

\*If result of specified function can not be obtained, (specified data does not exist etc.) [#Blank!], if use of function is wrong and unexpected error occurs, [#Error!] is displayed on the monthly report.

Function name		Argument	
ReportTime	Input date of the report. *Day 1 of the subject month is acquired.	/	
GetData	Input instantaneous value (Data at specified time).	Required(int)	DataNo : Data number
		Required(int)	Day : Date (Day)
		Required(int)	Hour : Time (hr)
		Required(int)	Minute : Time (min)
		Required(int)	Second : Time (sec)
Max	Input max value.	Optional (int)	DataNo : Data number
		Optional (int)	Day : Date (Day)
		Optional (int)	Hour : Time (hr)
Min	Input mini value.	Optional (int)	DataNo : Data number
		Optional (int)	Day : Date (Day)
		Optional (int)	Hour : Time (hr)
Average	Input average value.	Optional (int)	DataNo : Data number
		Optional (int)	Day : Date (Day)
		Optional (int)	Hour : Time (hr)
MaxTime	Input time when the max value is first detected.	Optional (int)	DataNo : Data number
		Optional (int)	Day : Date (Day)
		Optional (int)	Hour : Time (hr)
MinTime	Input time when the mini value is first detected.	Optional (int)	DataNo : Data number
		Optional (int)	Day : Date (Day)
		Optional (int)	Hour : Time (hr)
MaxName	Input data name of which the max value is first detected.	Optional (int)	Day : Date (Day)
		Optional (int)	Hour : Time (hr)
MinName	Input data name of which the mini value is first detected.	Optional (int)	Day : Date (Day)
		Optional (int)	Hour : Time (hr)

## &lt;Example of use of the function&gt;

ReportTime()	⇒ [Excel output result]	2015/1/1
GetData(DataNo=1,Day=8,Hour=13,Minute=30,Second=30)	⇒ [Excel output result]	150.05
Max()	⇒ [Excel output result]	500.00
		*Output MAX value of data of the monthly report
Max(DataNo=1)	⇒ [Excel output result]	500.00
		*Output MAX value of corresponding data number (e.g. data number 1) in the monthly report data.
Max(Day=8)	⇒ [Excel output result]	350.00
		*Output MAX value of corresponding date (e.g. day 8) in the monthly report data regardless of data number.
Max(Hour=15)	⇒ [Excel output result]	300.00
		*Output MAX value of corresponding time period (e.g. 15:00 to 16:00) in the monthly report data regardless of data number.
Max(DataNo=1,Day=8,Hour=15)	⇒ [Excel output result]	300.00
		*Output MAX value of corresponding data number corresponding day and time period (e.g. data number 1, day 8, 15:00 to 16:00) in the monthly report data.

●The data output conditions can be changed as well, by setting the arguments below.

Min()	⇒ [Excel output result]	-50.00
Min(DataNo=1)	⇒ [Excel output result]	-45.00
Min(Day=8)	⇒ [Excel output result]	-30.00
Min(Hour=15)	⇒ [Excel output result]	-30.00
Min(DataNo=1,Day=8,Hour=15)	⇒ [Excel output result]	-30.00
Average()	⇒ [Excel output result]	180.39
Average (DataNo=1)	⇒ [Excel output result]	230.52
Average (Day=8)	⇒ [Excel output result]	290.00
Average (Hour=15)	⇒ [Excel output result]	230.52
Average (DataNo=1,Day=8,Hour=15)	⇒ [Excel output result]	290.00
MaxTime()	⇒ [Excel output result]	2015/1/1 14:50:56
MaxTime (DataNo=1)	⇒ [Excel output result]	2015/1/1 14:50:56
MaxTime (Day=8)	⇒ [Excel output result]	2015/1/1 15:30:48
MaxTime (Hour=15)	⇒ [Excel output result]	2015/1/1 15:30:48
MaxTime (DataNo=1,Day=8,Hour=15)	⇒ [Excel output result]	2015/1/1 15:30:48
MinTime()	⇒ [Excel output result]	2015/1/1 10:16:12
MinTime (DataNo=1)	⇒ [Excel output result]	2015/1/1 10:16:12
MinTime (Day=8)	⇒ [Excel output result]	2015/1/1 10:16:12
MinTime (Hour=15)	⇒ [Excel output result]	2015/1/1 10:16:12
MinTime (DataNo=1,Day=8,Hour=15)	⇒ [Excel output result]	2015/1/1 10:16:12
MaxName()	⇒ [Excel output result]	DB600_PV_001
MaxName(Day=8)	⇒ [Excel output result]	DB600_PV_001
MaxName(Hour=15)	⇒ [Excel output result]	DB600_PV_001
MaxName(Day=8, Hour=15)	⇒ [Excel output result]	DB600_PV_001
MinName()	⇒ [Excel output result]	DB600_PV_001
MinName(Day=8)	⇒ [Excel output result]	DB600_PV_001
MinName(Hour=15)	⇒ [Excel output result]	DB600_PV_001
MinName(Day=8,Hour=15)	⇒ [Excel output result]	DB600_PV_001

◆ 14-3-3-2. Monthly report sample

Monthly report template is stored in next location. Copy it to the other location and use.  
(Pay attention not to delete the template.)

C:\Program Files (x86)\CHINO\TRAMS\Template\DailyReportSample.xlsx (For 64-bit)

C:\Program Files\CHINO\TRAMS\Template\DailyReportSample.xlsx (For 32-bit)

If output monthly report using the sample, following report is created. Design and layout can be arranged by Excel.

Monthly Report Sample										
December 1, 2020										
DAY	DATA1	DATA2	DATA3	DATA4	DATA5	DATA6	DATA7	DATA8	DATA9	DATA10
1	230.5	21.5	100	50.1	22.183	50.3	0	25.42	0	60
2	230.6	21.1	100	50.1	21.748	50.3	0	24.95	0	60
3	230.7	20.6	100	50.1	21.327	50.3	0	24.59	0.1	60
4	230.5	21.5	100	50.1	22.183	50.3	0	25.42	0	60
5	230.6	21.1	100	50.1	21.748	50.3	0	24.95	0	60
6	230.7	20.6	100	50.1	21.327	50.3	0	24.59	0.1	60
7	230.8	20.4	100	50.1	21.031	50.3	0	24.24	0	60
8	230.9	20.1	100	50.1	20.773	50.3	0	23.99	0	60
9	231	20	100	50.1	20.703	50.3	0	23.96	0	60
10	230.5	21.5	100	50.1	22.183	50.3	0	25.42	0	60
11	230.6	21.1	100	50.1	21.748	50.3	0	24.95	0	60
12	230.7	20.6	100	50.1	21.327	50.3	0	24.59	0.1	60
13	230.8	20.4	100	50.1	21.031	50.3	0	24.24	0	60
14	230.9	20.1	100	50.1	20.773	50.3	0	23.99	0	60
15	231	20	100	50.1	20.703	50.3	0	23.96	0	60
16	230.5	21.5	100	50.1	22.183	50.3	0	25.42	0	60
17	230.6	21.1	100	50.1	21.748	50.3	0	24.95	0	60
18	230.7	20.6	100	50.1	21.327	50.3	0	24.59	0.1	60
19	230.8	20.4	100	50.1	21.031	50.3	0	24.24	0	60
20	230.9	20.1	100	50.1	20.773	50.3	0	23.99	0	60
21	231	20	100	50.1	20.703	50.3	0	23.96	0	60
22	230.7	20.4	100	50.1	21.031	50.3	0	24.24	0	60
23	230.9	20.1	100	50.1	20.773	50.3	0	23.99	0	60
24	231	20	100	50.1	20.703	50.3	0	23.96	0	60
25	230.7	20.6	100	50.1	21.327	50.3	0	24.59	0.1	60
26	230.8	20.4	100	50.1	21.031	50.3	0	24.24	0	60
27	230.9	20.1	100	50.1	20.773	50.3	0	23.99	0	60
28	231	20	100	50.1	20.703	50.3	0	23.96	0	60
29	230.8	20.4	100	50.1	21.031	50.3	0	24.24	0	60
30	230.9	20.1	100	50.1	20.773	50.3	0	23.99	0	60
31	231	20	100	50.1	20.703	50.3	0	23.96	0	60
Max. value	231	21.7	100	50.1	22.471	50.3	0	25.66	0.4	60
Max. value detection time	7:45	2:27	2:27	2:27	2:28	2:27	2:27	2:27	3:44	2:27
Min. value	230.5	19.8	100	50.1	20.616	50.3	0	23.9	0	60
Min. value detection time	2:27	7:33	2:27	2:27	7:47	2:27	2:27	7:50	2:27	2:27
Ave. value	230.738	20.6238	100	50.1	21.328	50.3	0	24.5557	0.03178	60

### Caution

For cell format  
In the function, when numeric data is acquired, there is another function that obtains date and time. Change cell format depending on the contents of the function. Pay attention that if format is not applicable, error may occur.

### 14-3-4 Specific period printing

Print out the trend graph of designated period.

#### <Names of Parts on Period specific printing window>

The window is displayed by following operation.

[TRAMS]→[Data analysis]→[Data analysis]→[Open after file selection]→[Home]→[Specific Period Printing]

The screenshot shows a dialog box titled "Specified Period Print" with a close button (X) in the top right corner. The dialog contains several input fields and buttons, each labeled with a circled number:

- (1) Header: A text input field containing "Group 1".
- (2) Font: A font selection field showing "MS UI Gothic, 9pt".
- (3) Print Period: A dropdown menu currently set to "All".
- (4) Start Point Date and End Point Date: Two date and time input fields. The start date is "2018/10/30 10:46" and the end date is "2018/10/30 11:23".
- (5) Print Period per 1 Page: A text input field containing "10" followed by "min".
- (6) Scale Interval: A text input field containing "5" followed by "min".
- (7) Print: A button to execute the printing command.
- (8) Cancel: A button to exit the dialog without printing.

Num.	Name	Descriptions
(1)	Header	Specify header character string from 0 to 100 letters.
(2)	Font	Specify font information of a printout.
(3)	Printing period	Select and specify printing period from All/ Between cursors/ Display range/ Specify the period. *If period specific is selected, (4) Start/ End point Date Printing specify area becomes valid.
(4)	Start/ End point Date	Specify printing period: Start date and time to End date and time.
(5)	Print period per 1 page	Specify printing period for 1 page by [min] unit.
(6)	Scale interval	Specify scale division by [min] unit.
(7)	Print	Start printing. *Displays print preview.
(8)	Cancel	Ignores setting information and exits from period specific printing window.





### 14-3-5 [Connect to previous file], [Connect all files], [Connect to following file] functions

Functions to connect to a previous file, a subsequent file or all files in the same hierarchy as currently opened file.

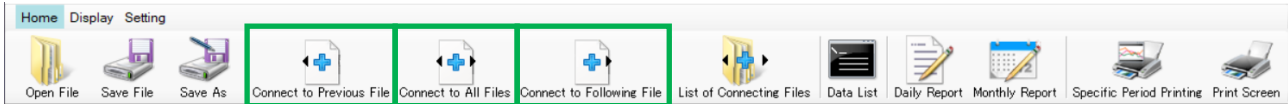
\*If reference folder in a list of connection file is already changed and connected, it connects to a file in the hierarchy.



 <b>Caution</b>	<p><b>Connection of acquired data file</b>  <b>Acquired data file can be connected. However, following conditions are required.</b></p> <ul style="list-style-type: none"> <li>· Acquired data files intended to connect should be same extension (*.dmf, *.a4f, *.krf, *.kpf or *.l5f file).</li> <li>· Contents of acquired data files intended to connect should be             <ul style="list-style-type: none"> <li>- Data memory interval is the same</li> <li>- Data count is the same</li> <li>- Group name is the same (Only for *.dmf)</li> <li>- CH number is the same (Only for *.a4f, *.krf, *.kpf or *.l5f)</li> </ul> </li> </ul> <p>*.zil file (Data analysis file) can not be connected.            *For condition setting, refer to 13-3-1. Group edit window and 13-6. Data memory operation window.</p>
--	--

 <b>Caution</b>	<p><b>Conditions of Connect to previous file and Connect to subsequent file</b></p> <p>[Connect to previous file button] and [Connect to subsequent file button] can only be used when following conditions are satisfied.</p> <ul style="list-style-type: none"> <li>· In addition to the above connection conditions, data should be connected</li> </ul> <p>(e.g.) If last data of currently opened file is of 5/25 10:00:00 and the interval is 1 sec, only data begins with 5/25 10:00:01 is subjected to [Connect to subsequent file].</p> <p>To connect to a previous file or a subsequent file which data is not sequential, use [Connect all files button] or connect by marking check at 14-3-6. List of connection file window.</p>
--	--

 <b>Caution</b>	<p><b>Data memory at the connection</b>  <b>It may take a while to load when performing connection of multiple files and it may affect behavior of data memory.</b>  <b>To be on the safe side, stop the data memory when connecting.</b></p>
--	---

### 14-3-6 List of connecting files window

Displays a list of connectable files.

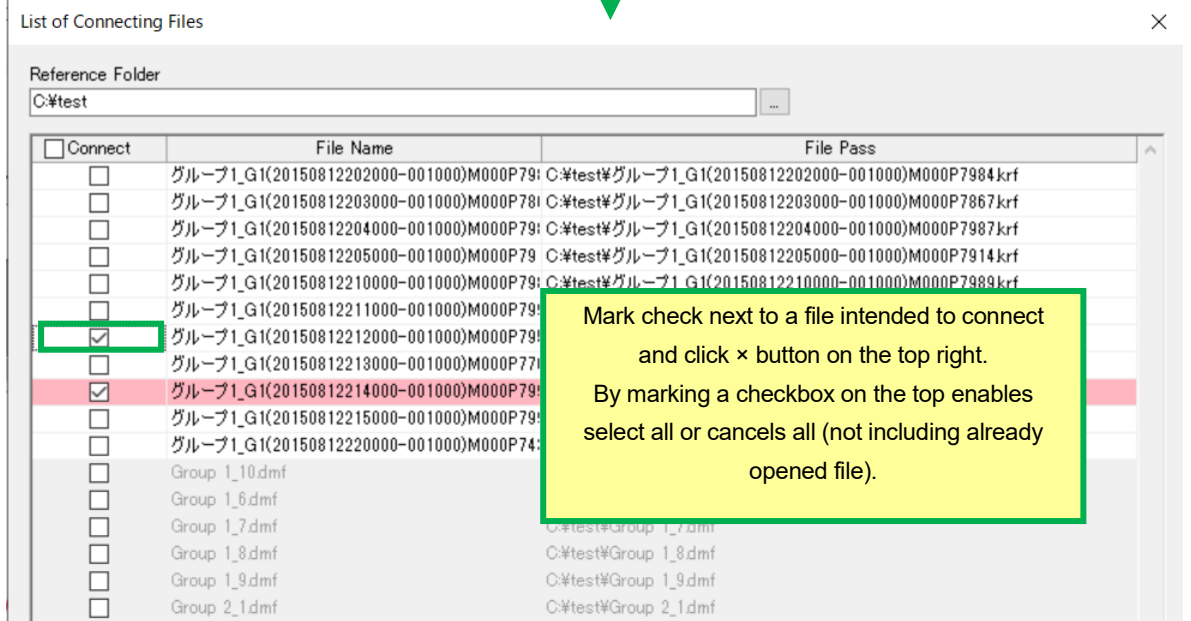
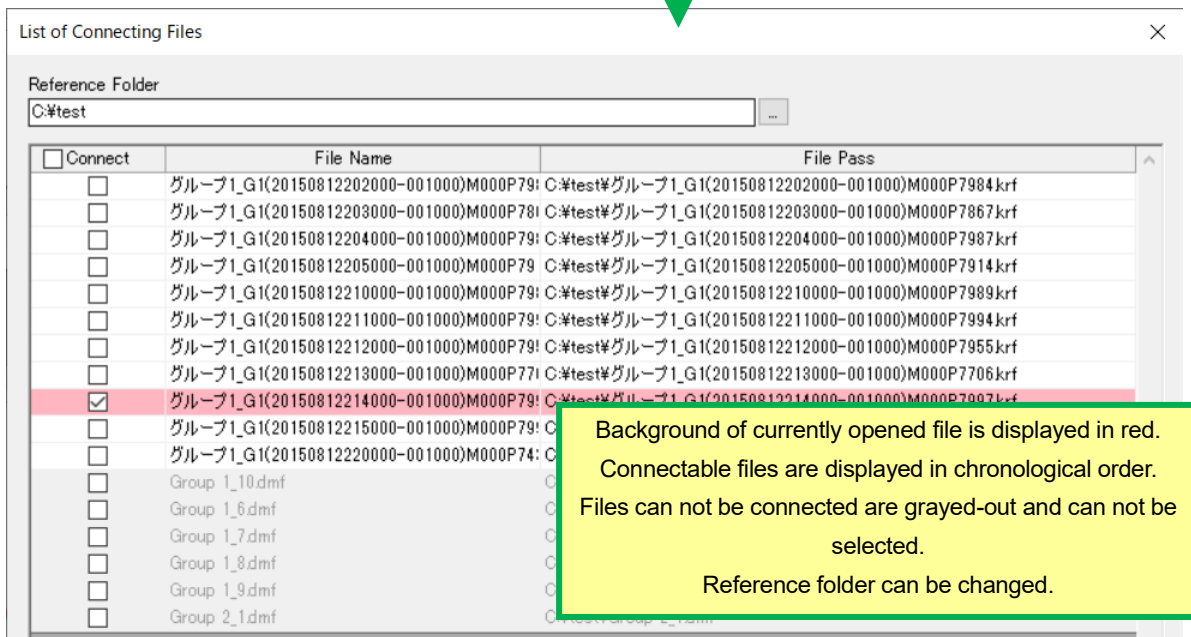
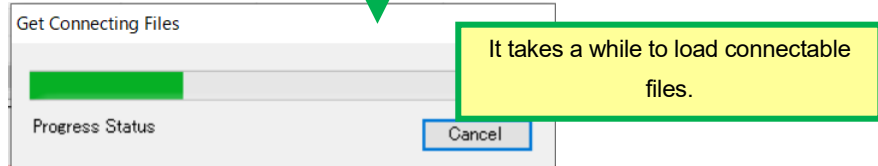
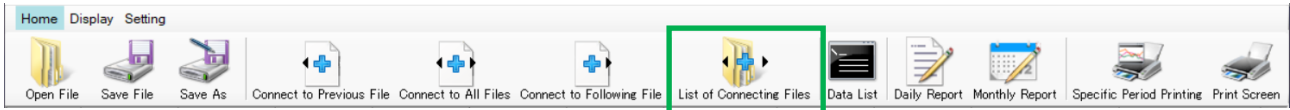

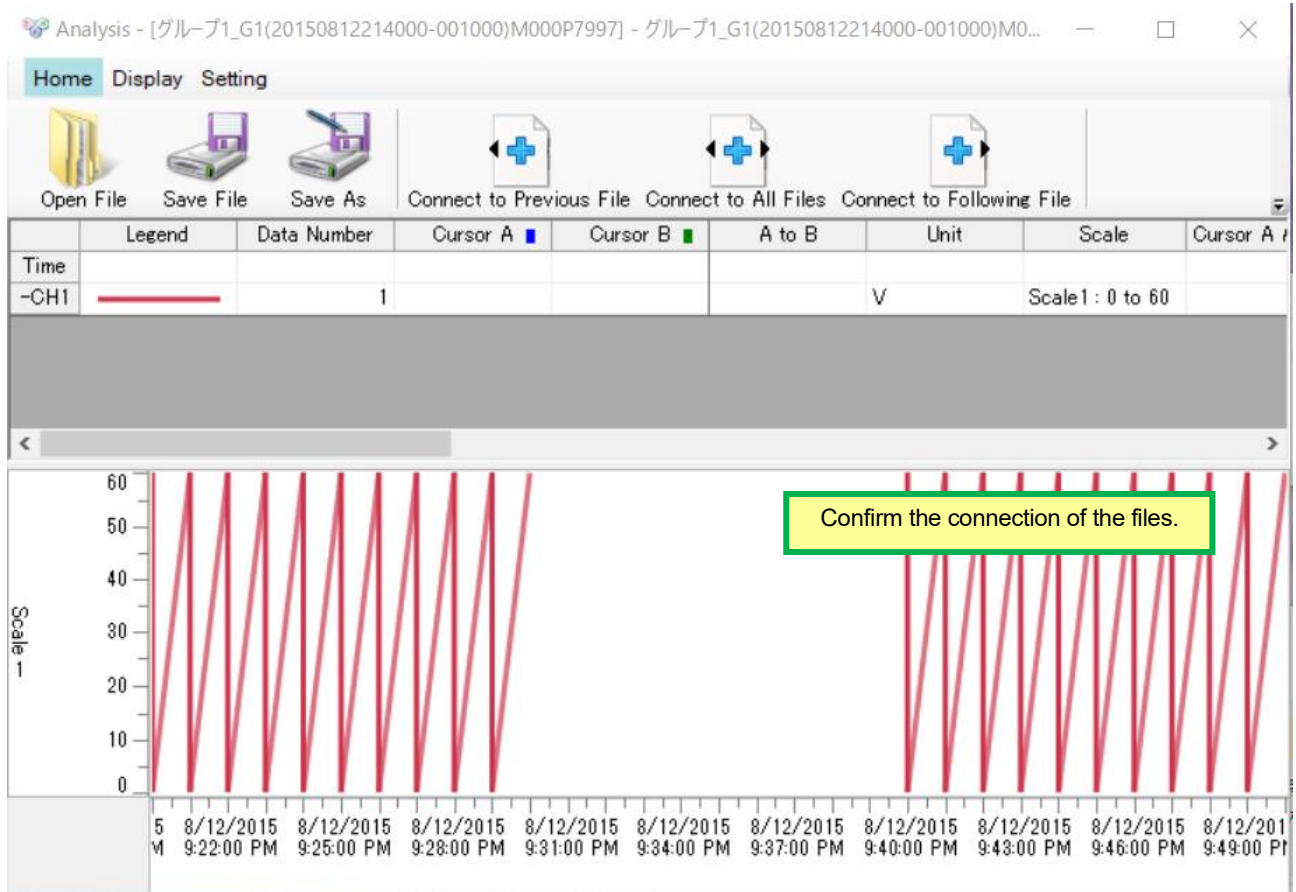
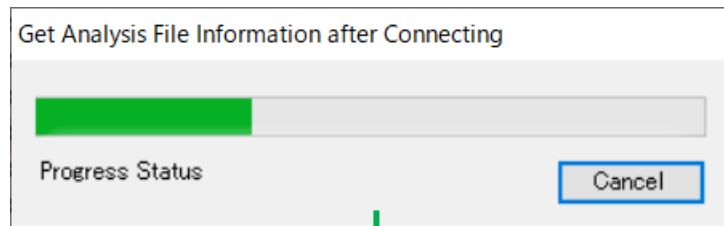

### Caution

#### Connection of files including same time

A file including same time data as currently opened file can not be selected at List of connection file window. It is displayed in grayed-out.



### Caution

#### Data memory at the connection

It may take a while to load when performing connection of multiple files and it may affect behavior of data memory. To be on the safe side, stop the data memory when connecting.

### 14-3-7 [Batch information display] window

When opening KR binary data file including batch information, Batch display button is displayed.  
(Function from TRAMS III version 3.0.0.4)

By clicking batch display button, batch information window is displayed and batch name, lot number, batch title and batch text included in the batch can be checked. Printing is also available.

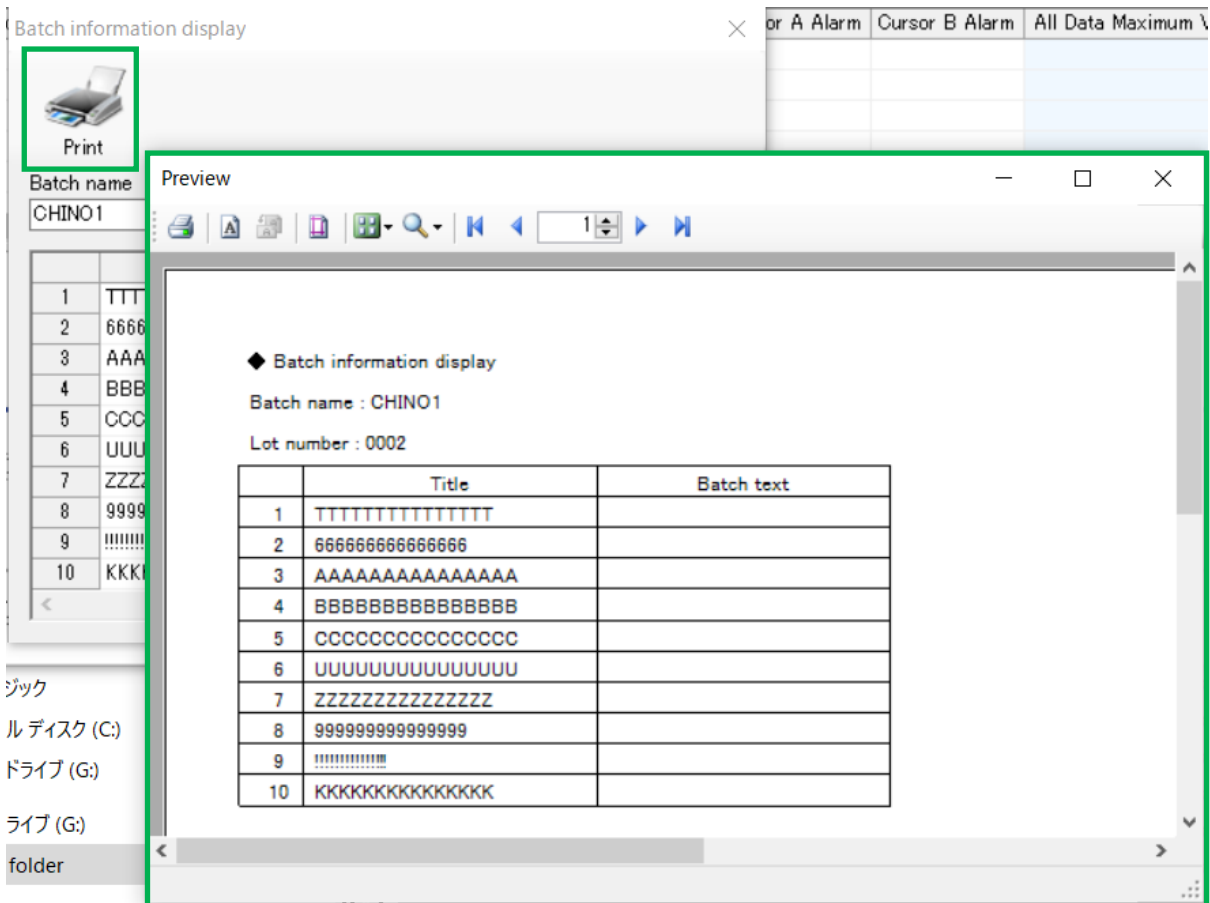
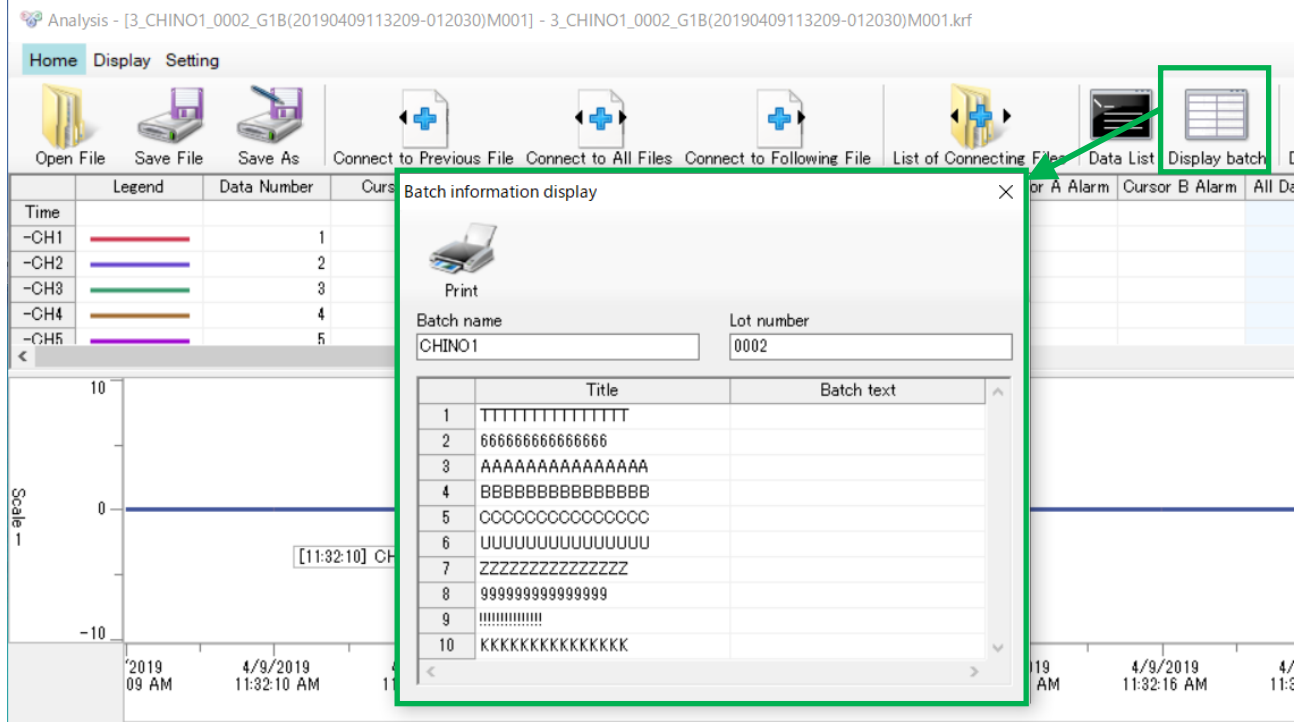

## 14-4 Operation of display

At display, display setting of data analysis can be changed.



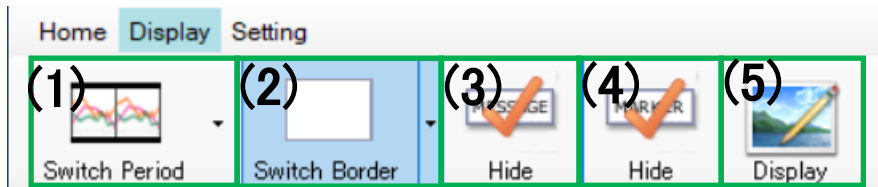

### <Names of Parts on Display of toolbar>

The window is displayed by following operation.

[TRAMS]→[Data analysis]→[Data analysis]→[Open after file selection]→[Display]

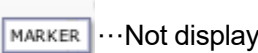

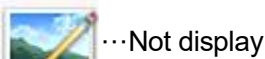
Num.	Name	Descriptions
(1)	Display period switching	<p>Select and specify display period on the trend graph from All periods/ Standard/ Between AB cursors. It can be specified by clicking drop-down button and one of the icons shown below. Initial value: Standard</p> <p>*If Between AB cursors are selected, display area can be changed by clicking on the icon of the button (in the order of place AB cursors→ click the button).</p> <p>...All periods ...Standard ...Between AB cursors</p> <p>*Setting contents are to be maintained for the next time the data analysis window is opened. (Function from TRAMS III)</p>
(2)	Ruled line switching	<p>Select and specify ruled line display on the trend graph from None/ Standard/ Detail. It can be specified by clicking drop-down button and one of the icons shown below. Initial value: None</p> <p>...None ...Standard ...Detail</p> <p>*Setting contents are to be maintained for the next time the data analysis window is opened. (Function from TRAMS III)</p>
(3)	Message display switching	<p>Specify message on the trend graph from Not display/ Display and switch it. By clicking the button, Display/ Not display status changes.</p> <p>...Not display ...Display</p> <p>Initial value: Display</p> <p>*Setting contents are to be maintained for the next time the data analysis window is opened. (Function from TRAMS III)</p>

Num.	Name	Descriptions
(4)	Marker text display switching	<p>Specify marker text on the trend graph from Not display/ Display and switch it. By clicking the button, Display/ Not display status changes. *Double byte marker text display is supported from TRAMS II.</p>   <p>Initial value: Display *Setting contents are to be maintained for the next time the data analysis window is opened. (Function from TRAMS III)</p>
(5)	Handwriting input display switching	<p>Specify handwriting input on the trend graph from Not display/ Display and switch it. By clicking the button, Display/ Not display status changes.</p>   <p>Initial value: Display *Setting contents are to be maintained for the next time the data analysis window is opened. (Function from TRAMS III)</p>

## 14-5 Operation of setting

At setting, settings of data analysis can be done.

### <Names of Parts on Setting of toolbar>

The window is displayed by following operation.

[TRAMS]→[Data analysis]→[Data analysis]→[Open after file selection]→[Setting]

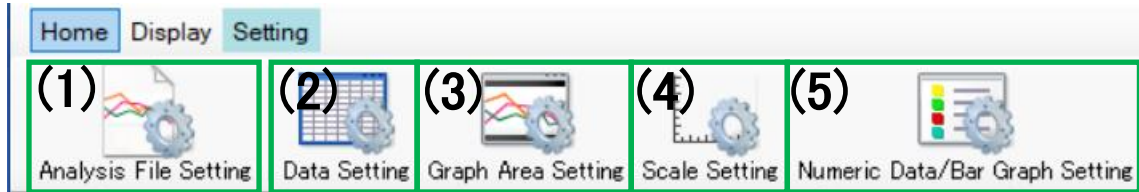

Num.	Name	Descriptions	Reference
(1)	Analysis file setting	Displays analysis file setting window.	14-5-1
(2)	Data setting	Displays data setting window.	14-5-2
(3)	Graph area setting	Displays graph area setting window.	14-5-3
(4)	Scale setting	Displays scale plate setting window.	14-5-4
(5)	Numeric data/ Bar graph setting	Displays numeric data/ bar graph setting window.	14-5-5

### 14-5-1 Analysis file setting window

Edits analysis file setting.

#### <Names of Parts on Analysis file setting window >

The window is displayed by following operation.

[TRAMS]→[Data analysis]→[Data analysis]→[Open after file selection]→[Setting]→[Analysis file setting]

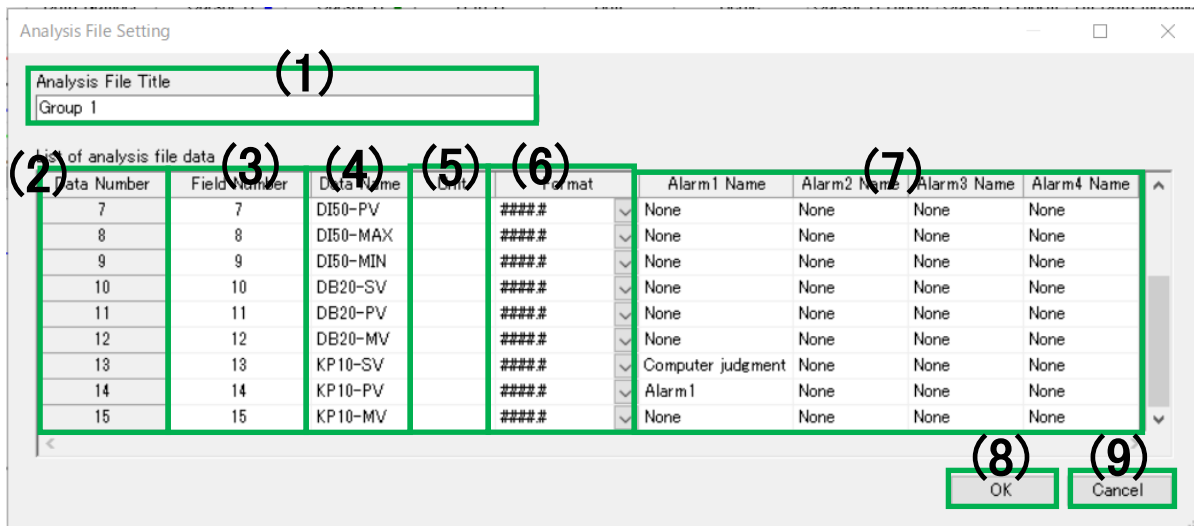

Num.	Name	Descriptions
(1)	Analysis file title	Specify analysis file title of a file opened on data analysis window. Up to 30 letters can be input. *Analysis file title specified at here is reflected on a header of the data analysis window.
(2)	Data number	Displays data value number existed on the data analysis window. It can not be changed.
(3)	Field number	Displays data No. at acquiring. It can not be changed.
(4)	Data name	Specify data name. Up to 30 letters can be input.
(5)	Unit	Specify unit. Up to 30 letters can be input.
(6)	Format	Select and specify display format of analysis data from #####/ #####.#/ ###.###/ ##.####/ #.#####/ 0E+00/ 0.0E+00/ 0.00E+00/ 0.000E+00.
(7)	Alarm 1 to 4 names	Specify alarm names. Up to 30 letters can be input.
(8)	OK	Holds setting information and reflects setting contents to the data analysis window.
(9)	Cancel	Ignores setting information and cancels reflecting setting contents to the data analysis window.



## 14-5-2 Data setting window

Edits data setting of the data analysis window.

### <Names of Parts on Data setting window>

The window is displayed by following operation.

[TRAMS]→[Data analysis]→[Data analysis]→[Open after file selection]→[Setting]→[Data setting]

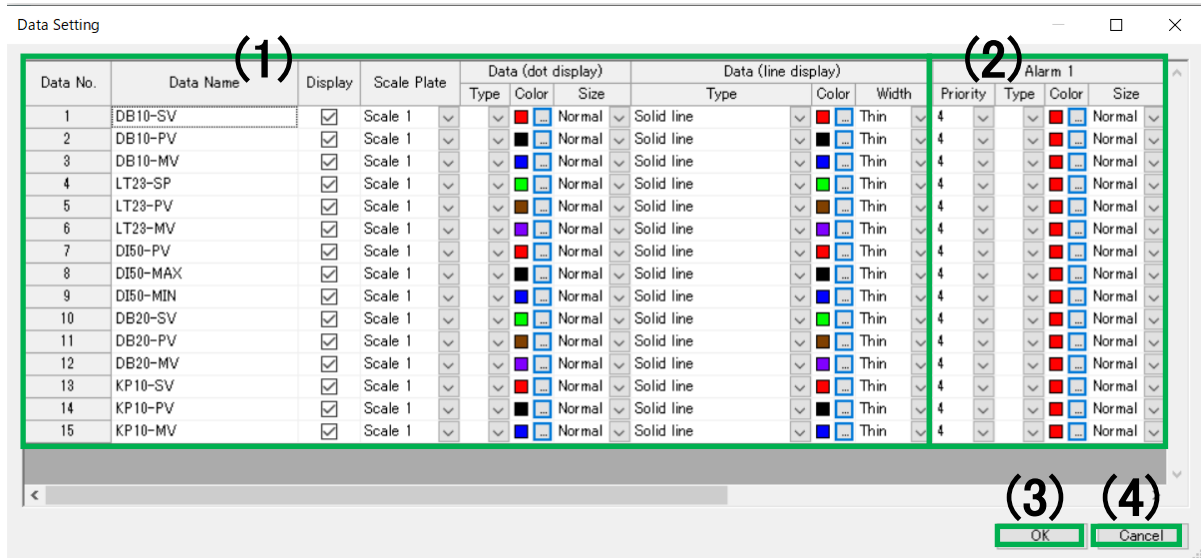

Num.	Name	Descriptions
(1)	Base setting area	<b>*Refer to names of parts on base setting area.</b>
(2)	Alarm setting area	<b>*Refer to names of parts on alarm setting area.</b>
(3)	OK	Holds setting information and reflects setting contents to the data analysis window.
(4)	Cancel	Ignores setting information and cancels reflecting setting contents to the data analysis window.

## &lt;Names of Parts on Base setting area&gt;

Data No. (1)	Data Name (2)	Display (3)	Scale Plate (4)	Data (dot display)			Data (line display)		
				Type	Color (5)	Size	Type (6)	Color	Width
13	KP10-SV	<input checked="" type="checkbox"/>	Scale 1		Red	Normal	Solid line	Red	Thin
14	KP10-PV	<input checked="" type="checkbox"/>	Scale 1		Black	Normal	Solid line	Black	Thin
15	KP10-MV	<input checked="" type="checkbox"/>	Scale 1		Blue	Normal	Solid line	Blue	Thin

Num.	Name	Descriptions
(1)	Data No.	Displays data No. at acquiring. It can not be changed.
(2)	Data name	Displays data name. It can not be changed.
(3)	Display	Specify whether or not to display data value. *With check mark: displays, without check mark: not display
(4)	Scale plate	Select and specify scale plate to plot data value from Scale 1 to Scale 10.
(5)	Dot setting	Specify type, color and size of the dot to display data value. *This setting is not applied to the data value including alarm. Refer to next section, <Names of Parts on Alarm setting area> to change dot display of data including alarm. <b>[Type]</b> Select and specify from None (blank)/ □/ ■/ ◇/ ◆/ △/ ▲/ ×/ * / ○/ ● / + . <b>[Color]</b> Specify from color dialog. <b>[Size]</b> Select and specify from Small/ Normal/ Big.
(6)	Line setting	Specify type, color and width of line to display data value. <b>[Type]</b> Select and specify from None (blank)/ Solid line/ Chain dash line/ Wave line/ Dash dotted line/ Dash double dotted line. <b>[Color]</b> Specify from color dialog. <b>[Width]</b> Select and specify from Thin/ Normal/ Thick.

<Names of Parts on Alarm setting area>

Alarm 1				Alarm 2				Alarm 3				Alarm 4			
Priority	Type	Color	Size	Priority	Type	Color	Size	Priority	Type	Color	Size	Priority	Type	Color	Size
4	▼	▼	▼	3	▼	▼	▼	2	▼	▼	▼	1	▼	▼	▼
4	▼	▼	▼	3	▼	▼	▼	2	▼	▼	▼	1	▼	▼	▼
4	▼	▼	▼	3	▼	▼	▼	2	▼	▼	▼	1	▼	▼	▼

Num.	Name	Descriptions
(1)	Alarm 1 to 4 setting area	<p>Specify type, color and size of the dot to display on each alarm.</p> <p><b>[Priority]</b>                      Select and specify from 1/ 2/ 3/ 4.                      *Priority is displayed as 1 [High] to 4 [Low].</p> <p><b>[Type]</b>                      Select and specify from None (blank)/ □/ ■/ ◇/ ◆/ △/ ▲/ ×/ * / ○ / ● / + .</p> <p><b>[Color]</b>                      Specify from color dialog.</p> <p><b>[Size]</b>                      Select and specify from Small/ Normal/ Big.</p>

### 14-5-3 Graph area setting window

Edits graph area setting of the data analysis window.

#### <Names of Parts on Graph area setting window>

The window is displayed by following operation.

[TRAMS]→[Data analysis]→[Data analysis]→[Open after file selection]→[Setting]→[Graph area setting]

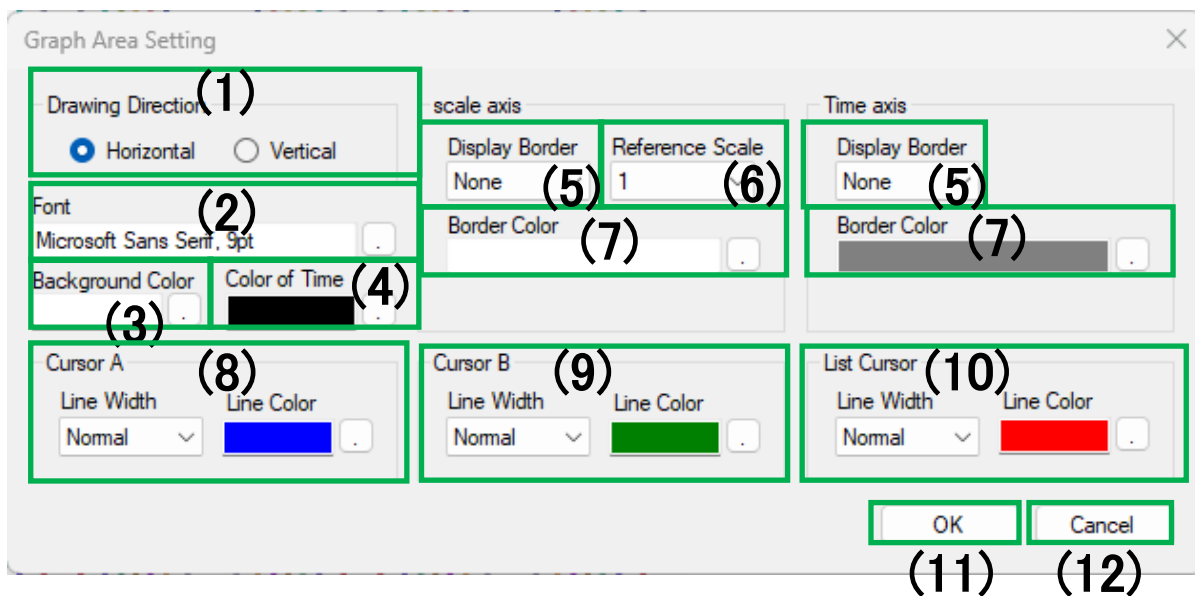

Num.	Name	Descriptions
(1)	Drawing direction*	Select and specify graph scroll method from Horizontal flow / Vertical flow. Initial value: Horizontal flow
(2)	Font*	Specify the font used at the graph area and time axis. Initial value: MS UI Gothic, 9pt
(3)	Background color*	Specify the background color of graph area. Initial value: White
(4)	Time color*	Specify foreground color of time axis. Initial value: Black
(5)	Display border*	Select and specify display type of ruled line from None/ Standard (displayed at the scale position)/ Detailed (displayed also at support scale position) / Detailed2 (displayed also in light colors at support scale position). Initial value: None
(6)	Reference scale*	Select and specify scale plate for ruled line display from 1 to 10. Initial value: 1
(7)	Border color*	Specify the color of ruled line. Initial value: Gray
(8)	Cursor A setting*	Specify line width and line color of cursor A. <b>[Line width]</b> Select and specify from Thin/ Standard/ Thick. Initial value: Standard <b>[Line color]</b> Specify from color dialog. Initial value: Blue
(9)	Cursor B setting*	Specify line width and line color of cursor B. <b>[Line width]</b> Select and specify from Thin/ Standard/ Thick. Initial value: Standard <b>[Line color]</b> Specify from color dialog. Initial value: Green
(10)	List cursor setting*	Specify line width and line color of list cursor.

		<b>[Line width]</b> Select and specify from Thin/ Standard/ Thick. Initial value: Standard <b>[Line color]</b> Specify from color dialog. Initial value: Red
(11)	OK	Holds setting information and reflects setting contents to the data analysis window.
(12)	Cancel	Ignores setting information and cancels reflecting setting contents to the data analysis window.

\* Setting contents are to be maintained for the next time the data analysis window is opened.  
(Function from TRAMS III)

### 14-5-4 Scale plate setting window

Edits scale plate setting of the data analysis window.

#### <Names of Parts on Scale plate setting window>

The window is displayed by following operation.

[TRAMS]→[Data analysis]→[Data analysis]→[Open after file selection]→[Setting]→[Scale plate setting]

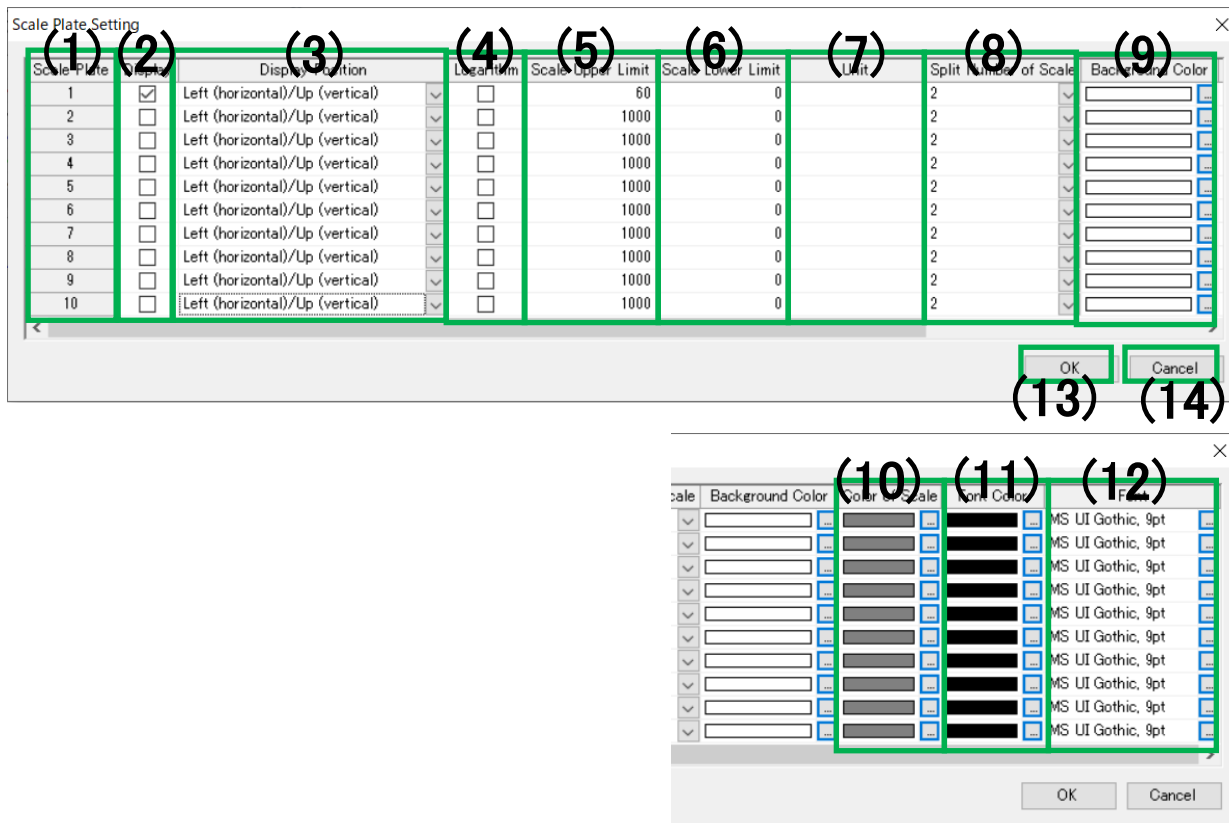

Num.	Name	Descriptions
(1)	Scale plate number	Display 1 to 10 scale plate number. It can not be changed.* <sup>1</sup>
(2)	Display	Specify whether or not to display scale plate. With check mark: displays, without check mark: not display Initial value: Check mark on 1* <sup>2</sup>
(3)	Display position*	Select and specify scale plate display position from left (horizontal) or up (vertical)/ right (horizontal) or bottom (vertical). Initial value: Both left (horizontal)/ up (vertical)* <sup>2</sup> By changing setting of Drawing direction of 14-5-3. Graph area setting window, left/ top or right/ bottom is changed automatically.
(4)	Logarithm*	Select and specify expression of scale value from normal or logarithm.* <sup>2</sup> *With check mark: logarithm, without check mark: normal Initial value: Both no check mark
(5)	Scale upper limit	Specify scale plate higher limit value from -99999.999 to 99999.999. For logarithm scale, it is exponential format. Initial value: For krf / kpf file, display scale higher limit value of KR start CH, for a4f/ l5f file, max value of SCALE-H, for dmf file, previous scale upper limit (if first opened file is dmf after first startup of the software, it is 1000)
(6)	Scale lower limit	Specify scale plate lower limit value from -99999.999 to 99999.999. For logarithm scale, it is exponential format.

		Initial value: For krf / kpf file, display scale lower limit value of KR start CH, for a4f/ l5f file, mini value of SCALE-L, for dmf file, previous scale lower limit (if first opened file is dmf after first startup of the software, it is 0)
(7)	Unit*	Specify the unit to display on the scale plate. Up to 30 letters can be input. Initial value: (Blank) * <sup>2</sup>
(8)	Split number of scale*	Select and specify number of scale line divisions from 2/ 3/ 4/ 5/ 6/ 7/ 8/ 9/ 10/ 11/ 12/ 13/ 14/ 15/ 16/ 17/ 18/ 19/ 20. This scale division is to control number of support scale lines which divide between main scales automatically assigned by scale higher/ lower limits (so depending on scale higher/lower limits setting, it may not be the divided number. For logarithm scale, it ignores set value and it is fixed to 9. Initial value: 2 * <sup>2</sup>
(9)	Background color*	Specify the background color of scale plate. Initial value: White* <sup>2</sup>
(10)	Scale plate color*	Specify the color of scale lines. Initial value: Gray* <sup>2</sup>
(11)	Font color	Specify the foreground color of scale value. Initial value: Black* <sup>2</sup>
(12)	Font*	Specify the font of scale value. Initial value: MS UI Gothic, 9pt* <sup>2</sup>
(13)	OK	Holds setting information and reflects setting contents to the trend graph setting window.
(14)	Cancel	Ignores setting information and cancels reflecting setting contents to the trend graph setting window.

\*<sup>1</sup> The number of scale plate is extended from 4 to 10. (Function from TRAMS v4.0.2.0)

\*<sup>2</sup> Setting contents are to be maintained for the next time the data analysis window is opened.  
(Function from TRAMS III)

### 14-5-5 Numeric data/ bar graph setting window

Edits numeric data/ bar graph setting of the data analysis window.

#### <Names of Parts on Numeric data/ bar graph setting>

The window is displayed by following operation.

[TRAMS]→[Data analysis]→[Data analysis]→[Open after file selection]→[Setting]→[Numeric data/ bar graph setting]

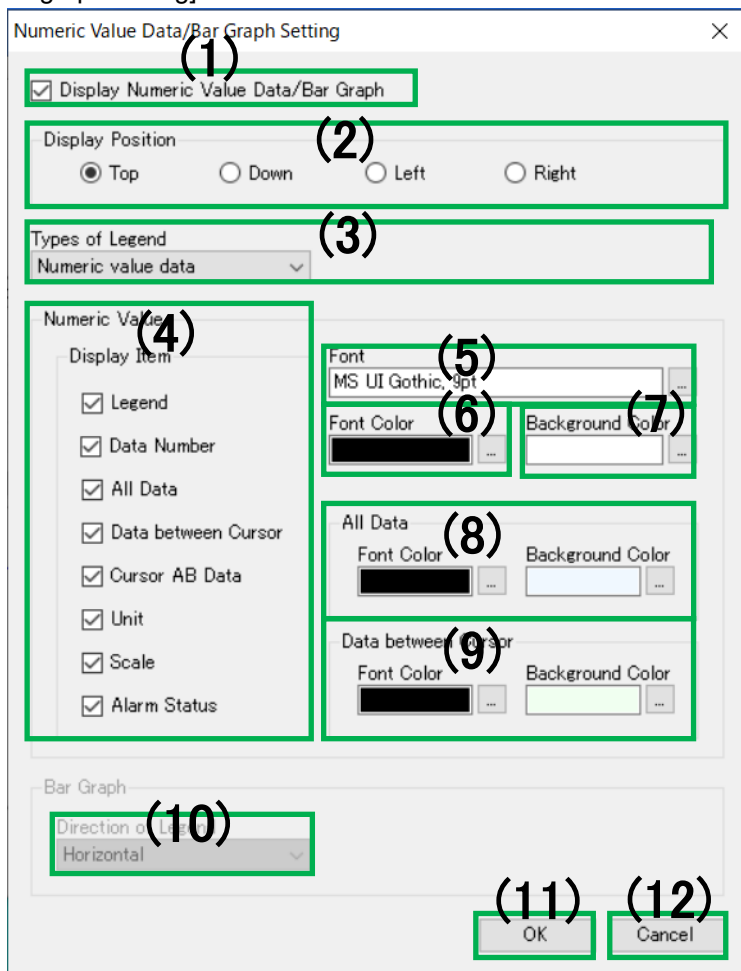

Num.	Name	Descriptions
(1)	Displays numeric data/ bar graph*	Specify whether or not to display Numeric data/ Bar graph. Initial value: With check mark With check mark: Displays, Without check mark: Not display
(2)	Display position*	Select and specify display position of numeric data/ bar graph from Top/ Bottom/ Left/ Right. Initial value: Top
(3)	Types of Legend*	Select and specify legend type from Numeric data/ Bar graph/ Stacked graph. Initial value: Numeric data If numeric data is selected, Numeric data setting area becomes valid and bar graph setting area becomes invalid. Bar graph/ Stacked graph is selected, Bar graph setting area becomes valid and Numeric data setting area becomes invalid. If it is changed to Bar graph/ Stacked graph, but no cursor is placed on the trend graph, nothing is displayed on the legend. To display Bar graph/



		Stacked graph on the legend, place a cursor on the trend graph of data analysis window.
(4)	Numeric data Display item*	Specify items to display on the numeric data. With check mark: Displays, Without check mark: Not display Initial value: Check mark on all
(5)	Numeric data Font*	Specify font information of numeric data. Initial value: MS UI Gothic, 9pt
(6)	Numeric data Font color*	Specify foreground color of numeric data. Initial value: Black
(7)	Numeric data Background color*	Specify background color of numeric data. Initial value: White
(8)	All data setting*	Specify font color and background color related to numeric data all data row. Font color initial value: Black Background color initial value is placed at color selection dialog [Custom colors (C)] (Light blue)
(9)	Numeric Between cursors data setting*	Specify font color and background color related to numeric data between cursors data. Font color initial value: Black Background color initial value is placed at color selection dialog [Custom colors (C)] (Light green)
(10)	Direction of bar graph legend`	Specify bar graph direction. Initial value: horizontal (Gray-out)
(11)	OK	Holds setting information and reflects setting contents to trend graph display window.
(12)	Cancel	Ignores setting information and cancels reflecting setting contents to trend graph display window.

\*Setting contents are to be maintained for the next time the data analysis window is opened.  
(Function from TRAMS III)

## 14-6 Numeric data/ Bar graph display area

Displays numeric data or bar graph at data analysis window.

\*It is related to 14-7. Trend graph display area, so by moving BA cursors on the trend graph, recalculation is done and display contents changes.

\*If it is changed to Bar graph / Stacked graph display at 14-5-5. Numeric data/ bar graph setting window, data value of cursor AB is displayed in a graph. (If cursors are not placed, nothing is displayed.)

### <Names of Parts on Numeric data>

The window is displayed by following operation.

[TRAMS]→[Data analysis]→[Data analysis]→[Open after file selection]

Time	Legend	Data Number	Cursor A	Cursor B	Cursor B Alarm	All Data Maximum Value	All Data Minimum Value	All Data Average Value	All Data Standard Deviation	All Data Median Value
No10-CH1	(2)	1	(1)			24.5	24.1	24.3	0.1	24.3
No10-CH2		2				27	27	27	0	27
No10-CH3		3				26.6	26.9	26.6	0.2	26.4
No10-CH4		4				20.9	20.3	20.3	0.2	20.6

Num.	Name	Descriptions
(1)	Basic data, Cursor A, B data display area	<b>*Refer to &lt;Names of Parts on Basic data, Cursor A, B data&gt;.</b> *14-5-5. Numeric data/ bar graph setting window is displayed by double-click.
(2)	All data, between cursors data display	<b>*Refer to &lt;Names of Parts on All data, Data between cursors&gt;.</b> *14-5-5. Numeric data/ bar graph setting window is displayed by double-click.

### <Names of Parts on Basic data, Cursor A, B data>

(1)	Legend	Data Number	Cursor A	Cursor B	A to B	Unit	Scale	Cursor A Alarm	Cursor B Alarm
(2)	(3)	(4)	(5)	(6)	(7)	(8)	(9)	(10)	
No10-CH1		1				°C	Scale1 : -200 to 1370		
No10-CH2		2				°C	Scale1 : -200 to 1370		
No10-CH3		3				°C	Scale1 : -200 to 1370		
No10-CH4		4				°C	Scale1 : -200 to 1370		
No10-CH5		5				°C	Scale1 : -200 to 1370		

Num.	Name	Descriptions
(1)	Data name	Data name is displayed as headers of the rows.
(2)	Legend	Legend lines are displayed for each data value.
(3)	Data number	Data numbers at acquiring for each data value are displayed.
(4)	Cursor A	Among each data value, values of the cursor A position are displayed. For time column, times of subject data values are displayed. Displayed color next to the header shows the cursor color. *This is displayed at a timing when 14-7. Trend graph display area cursor A, B are placed. Data value is deleted when cursor A is erased.
(5)	Cursor B	Among each data value, values of the cursor B position are displayed. For time column, times of subject data values are displayed. Displayed color next to the header shows the cursor color. *This is displayed at a timing when 14-7. Trend graph display area cursor A, B are placed. Data value is deleted when cursor B is erased.
(6)	A-B	Displays the data difference obtained by subtracting the cursor B data value from the cursor A data value while (4)·(5) are displayed. *This is displayed at a timing when 14-7. Trend graph display area cursor A, B are placed. Calculation result is deleted when cursor A or B is erased.
(7)	Unit	Display units specified for each data value.
(8)	Scale	Display scale information of scale plate specified for each data value.
(9)	Cursor A alarm	Display alarm status of cursor A for each data.

(10)	Cursor B alarm	Display alarm status of cursor B for each data.
------	----------------	---

< Names of Parts on All data, Data between cursors >

Data Maximum Value	Data Minimum Value	Data Average Value	Data Standard Dev	Data Median Value	Cursor Maximum Value	Cursor Minimum Value	Cursor Average Value	Standard De	Cursor Median Value
(1) 24.5	(2) 24.1	(3) 24.3	(4) 0.1	(5) 24.3	(6) 24.3	(7) 24.3	(8) 24.3	(9) 0	(10) 24.3
27	27	27	0	27	27	27	27	0	27
26.6	25.9	26.3	0.2	26.4	26.4	26.4	26.4	0.0	26.4
20.9	20.3	20.6	0.2	20.6	20.4	20.4	20.4	0.0	20.4
*****	*****	*****	*****	*****	*****	*****	*****	*****	*****

Num.	Name	Descriptions
(1)	All data max value	Displays max value of all data for each data value.
(2)	All data mini value	Displays mini value of all data for each data value.
(3)	All data average value	Displays average value of all data for each data value.
(4)	All data standard deviation	Displays standard deviation of all data for each data value.
(5)	All data median value	Displays median value of all data for each data value.
(6)	Cursor max value	Displays max value of data between cursor A, B for each data value.
(7)	Cursor mini value	Displays mini value of data between cursor A, B for each data value.
(8)	Cursor average value	Displays average value of data between cursor A, B for each data value.
(9)	Cursor standard deviation	Displays standard deviation of data between cursor A, B for each data value.
(10)	Cursor median value	Displays median value of data between cursor A, B for each data value.

## 14-7 Trend graph display area

Displays analysis data file as a graph on the data analysis window.

\*This is linked to 14-6. Numeric data/ bar graph display area, so by moving cursor A, B on the trend graph, recalculation is done and display contents are changed.

### <Names of Parts on Trend graph display area>

The window is displayed by following operation.

[TRAMS]→[Data analysis]→[Data analysis]→[Open after file selection]

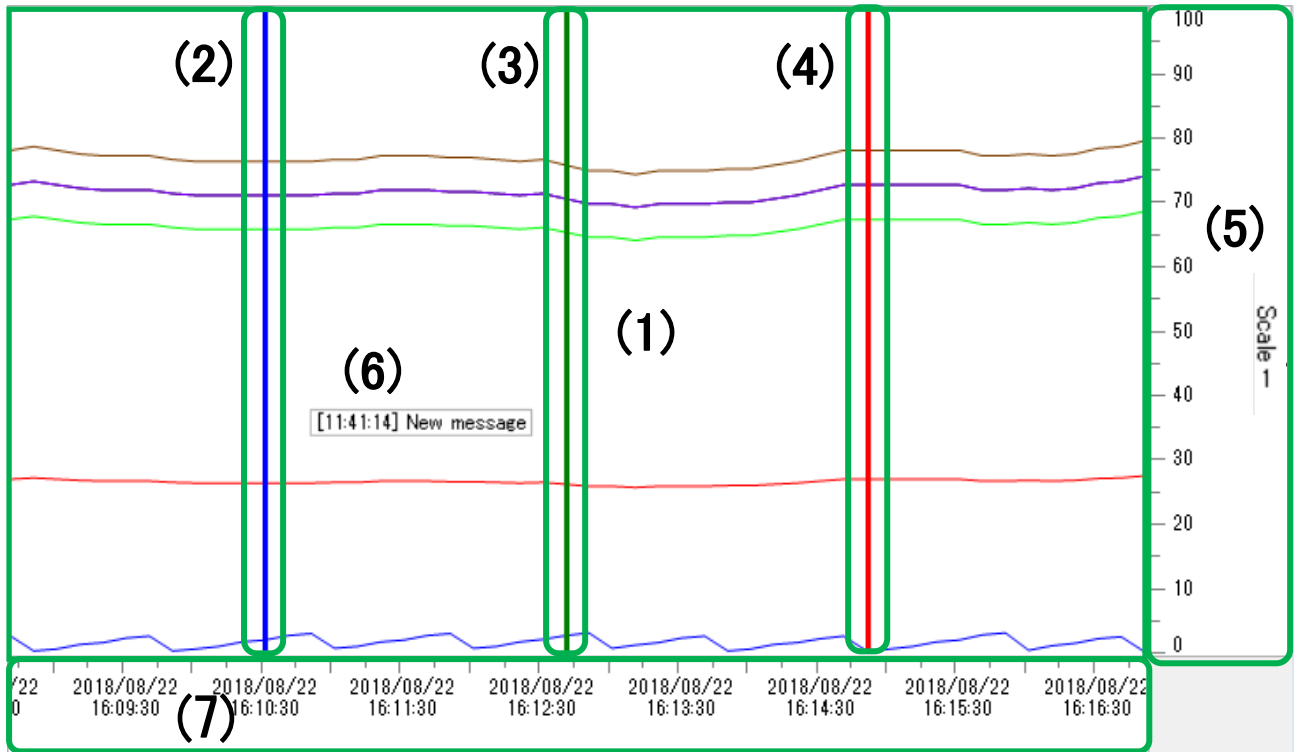

Num.	Name	Descriptions	Reference
(1)	Graph area	Plots analysis data value and displays as a graph etc. *Displays ruled line according to the reference scale and cursor A, B. *By right-clicking inside the area, menu of add new of (6) Message is displayed.	
(2)	Cursor A (Blue)	Cursor A is displayed by clicking the mouse on (1) Graph area. Cursor move: Select cursor A by clicking and drag by the mouse or press arrow key. Cursor delete: Select cursor A and press Delete key.	
(3)	Cursor B (Green)	Cursor B is displayed after displaying (3) Cursor A and drag by the mouse. Cursor move: Select cursor B by clicking and drag by the mouse or press arrow key. Cursor delete: Select cursor B and press Delete key.	

Num.	Name	Descriptions	Reference
(4)	List cursor (Red)	By double-clicking on 14-3-1. Data list display window, list cursor is displayed at applicable data position*1. Cursor move: Select list cursor by clicking and drag by the mouse or press arrow key. Cursor delete: Select list cursor and press Delete key. If the data list display window is closed, list cursor disappears at the same time.	

\*1 List cursor (red) is linked to the data list display. The data list display is displayed by following operation.

[TRAMS]→[Data analysis]→[Data analysis]→[Open after file selection]→[Home]→[Data list]

Click data list display button

Time	Legend	Data Num	Cursor A	Cursor B	Unit	Scale	Cursor A Alarm	or B A	Data Maximum Va	Data Minimum V	Data Avera
2018/02/1			2018/02/1	2018/02/1							
No10-CH1	Red	1	24.2	24.2	°C	Scale1 : -9.522 to 37.737			24.5	24.1	
No10-CH2	Blue	2	27	27	°C	Scale1 : -9.522 to 37.737			27	27	
No10-CH3	Green	3	26.1	26.1	°C	Scale1 : -9.522 to 37.737			26.6	25.9	
No10-CH4	Brown	4	20.7	20.7	°C	Scale1 : -9.522 to 37.737			20.9	20.3	
No10-CH5	Purple	5	Flurn	Flurn	°C	Scale1 : -9.522 to 37.737			*****	*****	*****

By double-clicking on the data list display, list cursor (red) is displayed on the data analysis trend graph.

Num.	Name	Descriptions	Reference
(5)	Scale plate area	Displays ruled line reference scale of (1) graph area. *Scale plate setting such as higher limit/ lower limit etc. can be edited at 14-5-4. Scale plate setting window.	14-7-1
(6)	Message/ Marker text/ Handwriting input	Displays optional message, marker text, and handwriting input on (1) Graph area. *As for message, right-clicking on (1) Graph area displays menu of add new. It moves to editing status by double-clicking. (Marker text and handwriting input can not be add as new. Only loading data file recorded by devices is available.) *Double byte marker text display is supported from TRAMS II.	14-7-2
(7)	Time axis area	Displays time axis of (1) Graph area. *Enlarged image is displayed by dragging the area by the mouse. Enlarged time axis is returned to the initial state by right-click.	

### 14-7-1 Operation of scale plate area

(1)Reference scale of each data value is set at 14-5-2. Data setting window.

(2)By specifying the area of scale plate display area with mouse drag, scale area can be enlarged. Enlarged scale is returned to the initial state by right-click and choosing “Cancel scale enlargement (E)”.

(3)By clicking each scale, only the data assigned to the scale is displayed. All the data is displayed by scale right-click and choosing “Cancel data display of the selected scale (V)”.

(4)By specifying the area of scale plate display frame, display size of the scale plate can be changed.

(1)

Reference scale of each data is set at data setting window.

Data No.	Data Name	Display	Scale Plate	Type	Color	Size
1	No10-CH1	<input checked="" type="checkbox"/>	Scale 1		Red	Normal
2	No10-CH2	<input checked="" type="checkbox"/>	Scale 1		Blue	Normal
3	No10-CH3	<input checked="" type="checkbox"/>	Scale 1		Green	Normal
4	No10-CH4	<input checked="" type="checkbox"/>	Scale 1		Brown	Normal

(2)

By dragging display area of the scale plate, width of the scale plate can be changed.

(3)

(4)

Scale plate width is changed by dragging this vertical line.

Pop-up menu when the scale is right-clicked:

If the “Cancel all (A)” is clicked, it cancels both “Cancel scale enlargement (E)” and “Cancel data display of the selected scale (V)”.

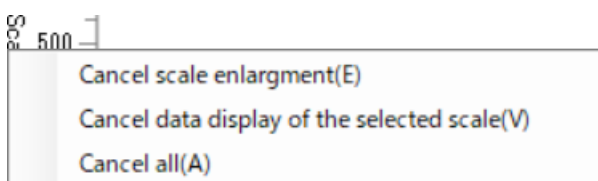

## 14-7-2 Operation of message

Message can be added and edited at 14-7. Trend graph display area by using sub-menu displayed by right-click.

### <Names of Parts on Message add sub-menu>

The window is displayed by following operation.

[TRAMS]→[Data analysis]→[Data analysis]→[Open after file selection]→[Right-click on the trend graph display area]

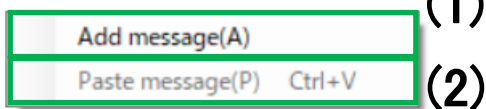

Num.	Name	Descriptions
(1)	Add message	Adds new message. Specify message character string by direct input. Up to 256 letters can be input.
(2)	Paste message	Pastes Copy/ Cut message. *It is valid if message subject to paste exist. *Short cut is available as Ctrl + V keys

### <Names of Parts on Sub-menu when message is selected>

The window is displayed by following operation.

[TRAMS]→[Data analysis]→[Data analysis]→[Open after file selection]→[Right-click on a message on the trend graph display area]

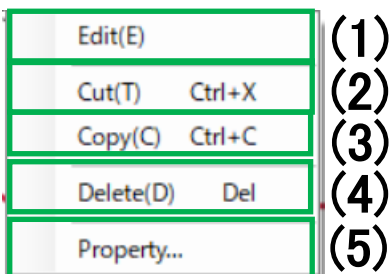

Num.	Name	Descriptions	Reference
(1)	Edit	Selected message is being in the edit state. Specify message character string by direct input. Up to 256 letters can be input.	
(2)	Cut	Cuts selected message. *Short cut is available as Ctrl + X keys	
(3)	Copy	Copies selected message. *Short cut is available as Ctrl + C keys	
(4)	Delete	Deletes selected message. *Delete key can be used for deleting.	
(5)	Properties...	Displays message property dialog of the selected message.	14-7-2-1



## ◆ 14-7-2-1. Property dialog

Adds or edits message by using displayed sub-menu.

**<Names of Parts on Message add sub-menu>**

The window is displayed by following operation.

[TRAMS]→[Data analysis]→[Data analysis]→[Open after file selection]→[Right-click on a message on the trend graph display area]→[Click on the property in the sub-menu]

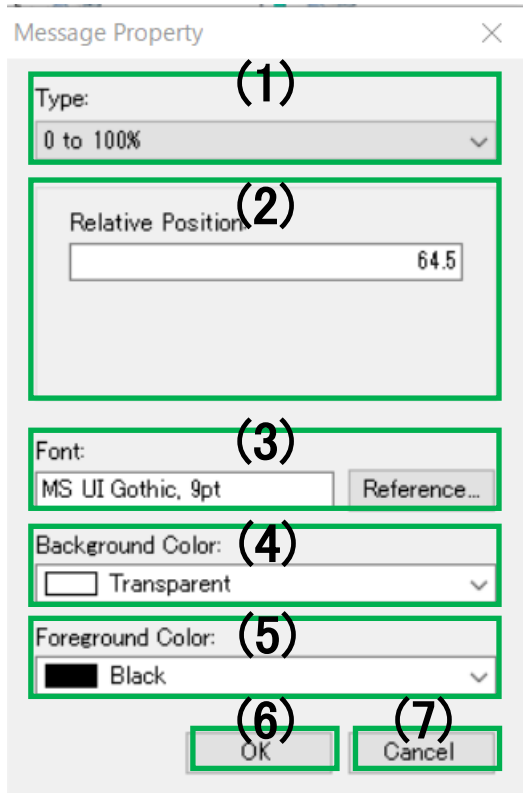

Num.	Name	Descriptions
(1)	Types	Select and specify message types from Refer to data series / Refer to scale axes / 0~100%.
(2)	Relative position / link setting area	Specify message position/ link setting. (1)Specify following items for each type. <b>[Refer to data series]</b> Specify data series to link. <b>[Refer to scale axes]</b> Specify scale to link. Specify position information on the scale. <b>[0~100%]</b> Specify relative position on the graph area.
(3)	Font	Specify a font to use for the message.
(4)	Background color	Specify background color of the message. *Transparent is selected, background color specified at 14-5-3. Graph area setting area is used.
(5)	Foreground color	Specify foreground color of the message. *Transparent is selected, background color specified at 14-5-3. Graph area setting area is used.
(6)	OK	Holds setting information and reflects setting contents to the selected message.
(7)	Cancel	Ignores setting information and cancels reflecting setting contents to the selected message.

### 14-7-3 Operation of marker text

Time data is also displayed in the mark text included in the KR binary data file.

Marker text can be moved by dragging it by the mouse or the arrow key operation.

However, time direction can not be moved.

(Both functions are available from TRAMS IV version 4.0.0.2)

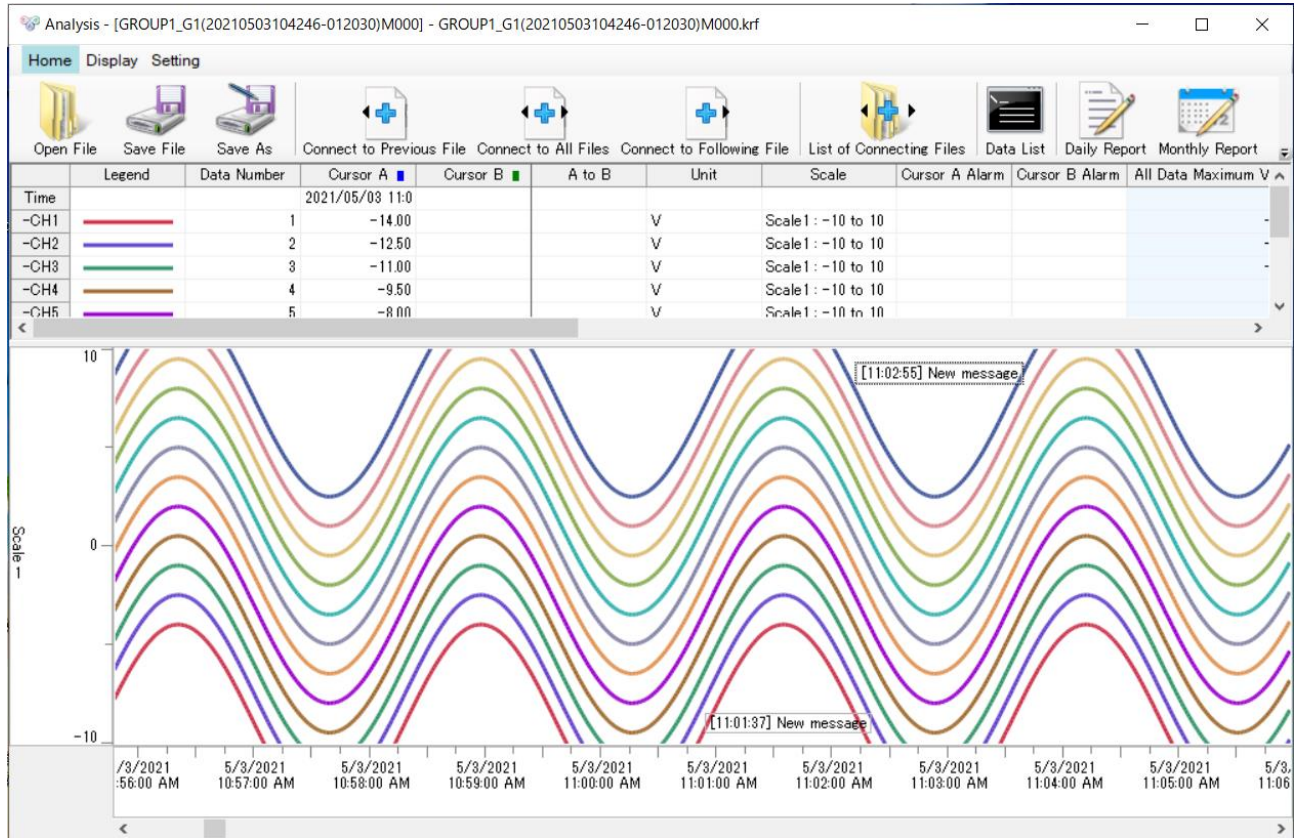

## 14-8 Signature operation

Review and sign the record data file (\*.kpf) for KR Heat Treatment Assistance Specification.

### Reference

The kpf file analysis and signature functions have been available since TRAMS IV version 4.0.5.0.

Supported KR Heat Treatment Assistance Specification is software version 1.40 or above. If it is below 1.40, it cannot be signed by TRAMS.

### <Names of Parts on Data analysis window>

The window is displayed by following operation.

[TRAMS]→[Data analysis]→[Data analysis]→[Open after file selection]

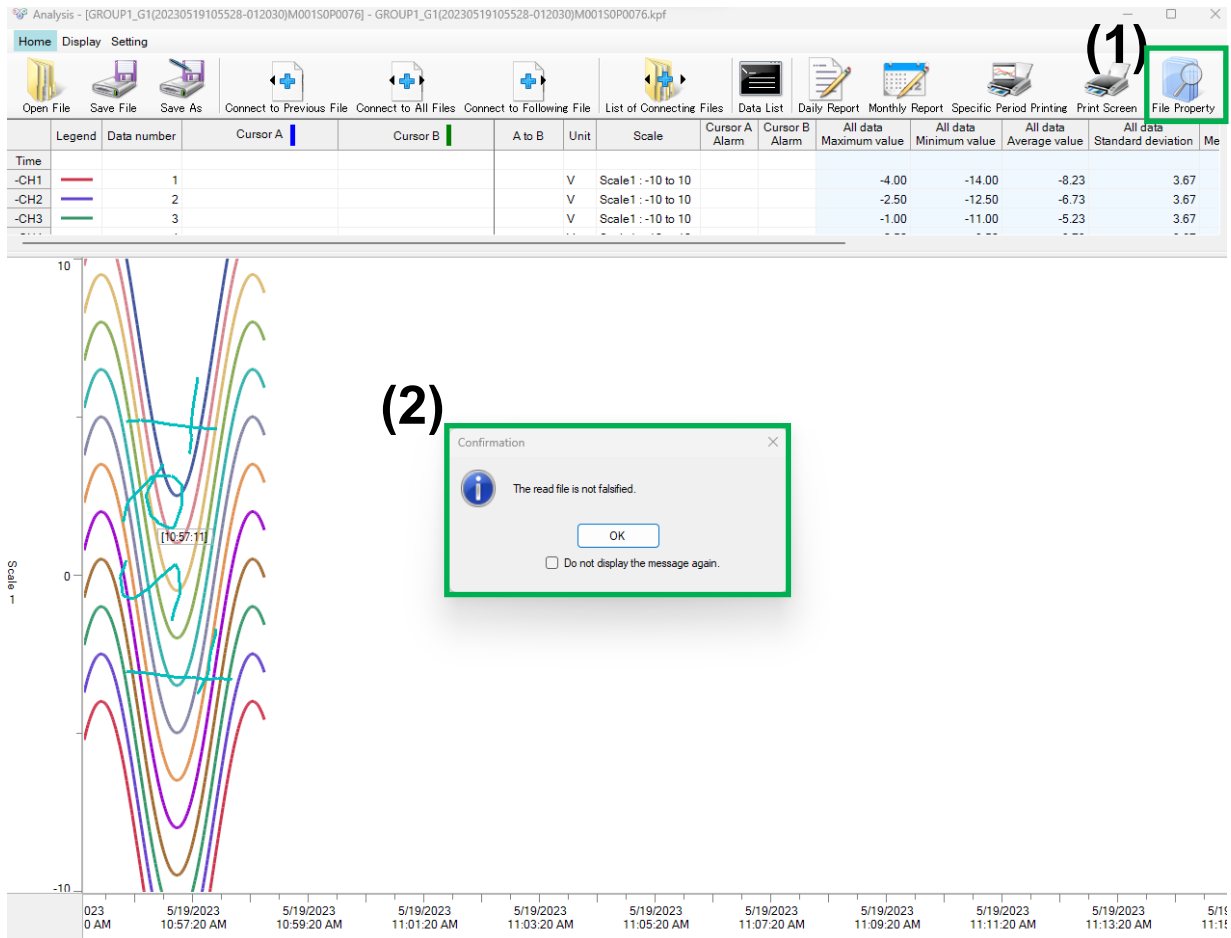

Num.	Name	Descriptions	Reference
(1)	File Property	Displays information about the data file. You can also sign the form.	14-8-1
(2)	Confirmation	Recorded data files (*.kpf) are encrypted to prevent tampering. A confirmation message indicates that the loaded file has not been tampered with. If you do not need the message display in the future, check the box and click the [OK] button.	14-8-2

## 14-8-1 File property

To sign, click the [Signature] button in the lower left corner.

Start Date	2023/05/16 14:38:58
End Date and Time	2023/05/16 14:39:59
Interval	1000msec
Number of data	62
Device name	
Serial Number	
Software Version	1.634
Setting file name	20230516143743kps
Sign1	Administrator 2023/05/18 23:31:25
Sign2	
Sign3	
Sign4	

When signing, a communication connection (Ethernet) to the KR main unit that created the data file is required.

Select from [Select from registered device] or [Specify IP address].

The user ID and password for signing is the ID and password for the administrator or general user set in the KR main unit.

Click the [OK] button.

Select the connection point from which to obtain signature information.

Select from registered devices

Model	Device name	Address
KR2S2PSG0A-NNN	001_KR2S	192.168.254.254

Specify IP address

192 . 168 . 254 . 254

Enter user ID and password for signature

User ID: U1 Password: ●●●●

If you connect to a KR other than the one which the recording is conducted, an error message is displayed and you will not be able to sign it.

**×** The device serial number of the file to be signed is different. Please connect to the device on which the record was conducted.

Only when it is connected through communication and the conditions for signing are met, the message [Are you sure you want to sign?] appears.

Click [Yes] to sign.

**i** Are you sure you want to sign ?

Signatures are carried out in the order from the lower levels. It will be signed with the full name set on the KR main unit.

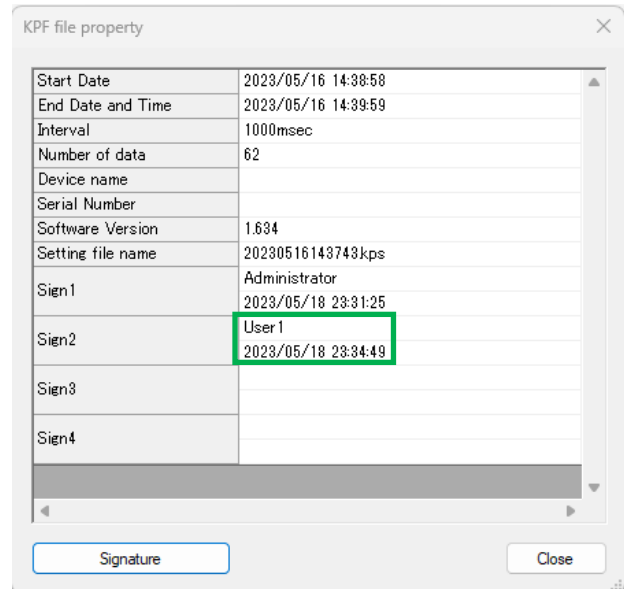

After the signature, part of the file name is changed.

GROUP1\_T1\_00000003\_G1B(20230516143858-012030)M000S2.kpf

Unsigned: S0

Signed up to level 1: S1

Signed up to level 2: S2

Signed up to level 3: S3

Signed up to level 4: S4

Signature cannot be canceled.

#### Reference

Signatures are done in accordance with KR Heat Treatment Assistance Specification.

Refer to the instruction manual for details.

## 14-8-2 Other setting functions

### <Names of Parts on Various toolbars/ Settings>

The window is displayed by following operation.

[TRAMS]→[Data analysis]→[Data analysis]→[Open after file selection]→[Setting]→[Other Function Settings]

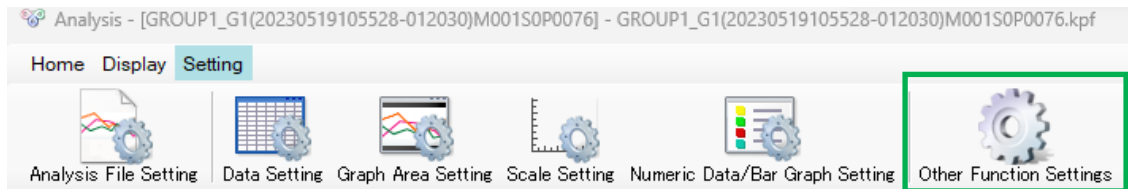

Display/ non-display of confirmation message when not tampered with.

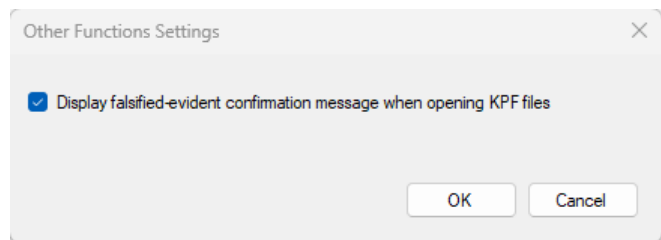

When you try to open a file that has been tampered with, regardless of the above settings, the message [Failed to read file. Detail: File cannot be opened because it has been falsified.] is displayed.

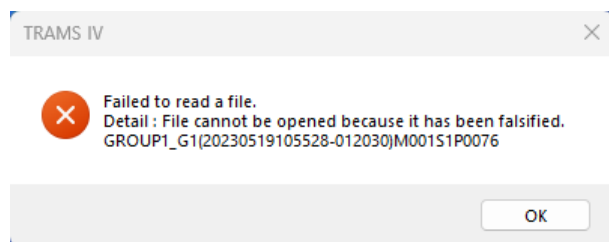

## 15 Operation of Favorite

On favorite, function of the TRAMS launcher in your discretion can be added so frequently used functions can be started up and operated smoothly.

### <Names of Parts on Launcher Favorite>

The window is displayed by following operation.

[TRAMS]→[Favorite]

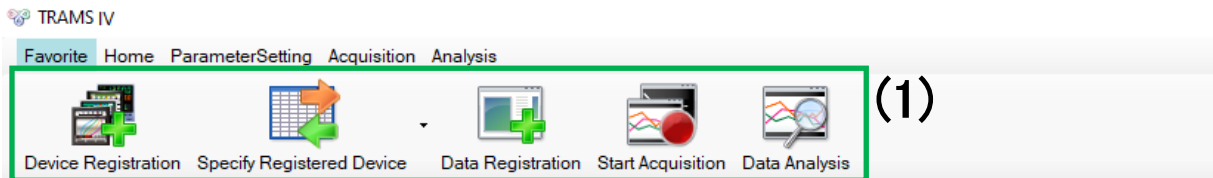

Num.	Name	Descriptions
(1)	Favorite tool button display area	Displays tool buttons added or registered by the user's discretion. *Refer to <Flow of adding Favorite>

**<Flow of adding Favorite>**

Optional tool button can be added to [Favorite] menu by following the operations below.

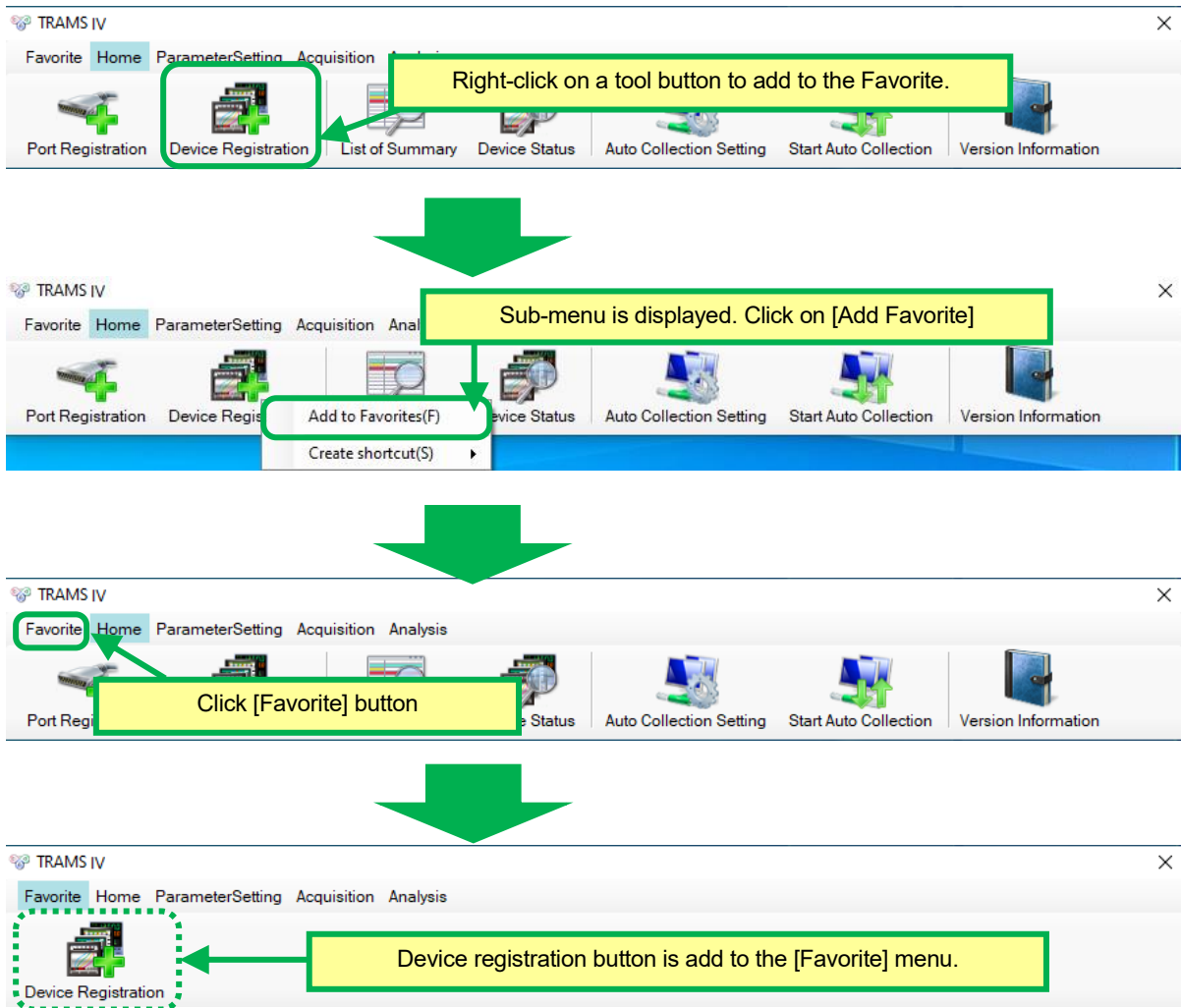



### <Flow of making Shortcut>

\*Shortcut can be made on the desktop or the place in your discretion by specifying the file name.

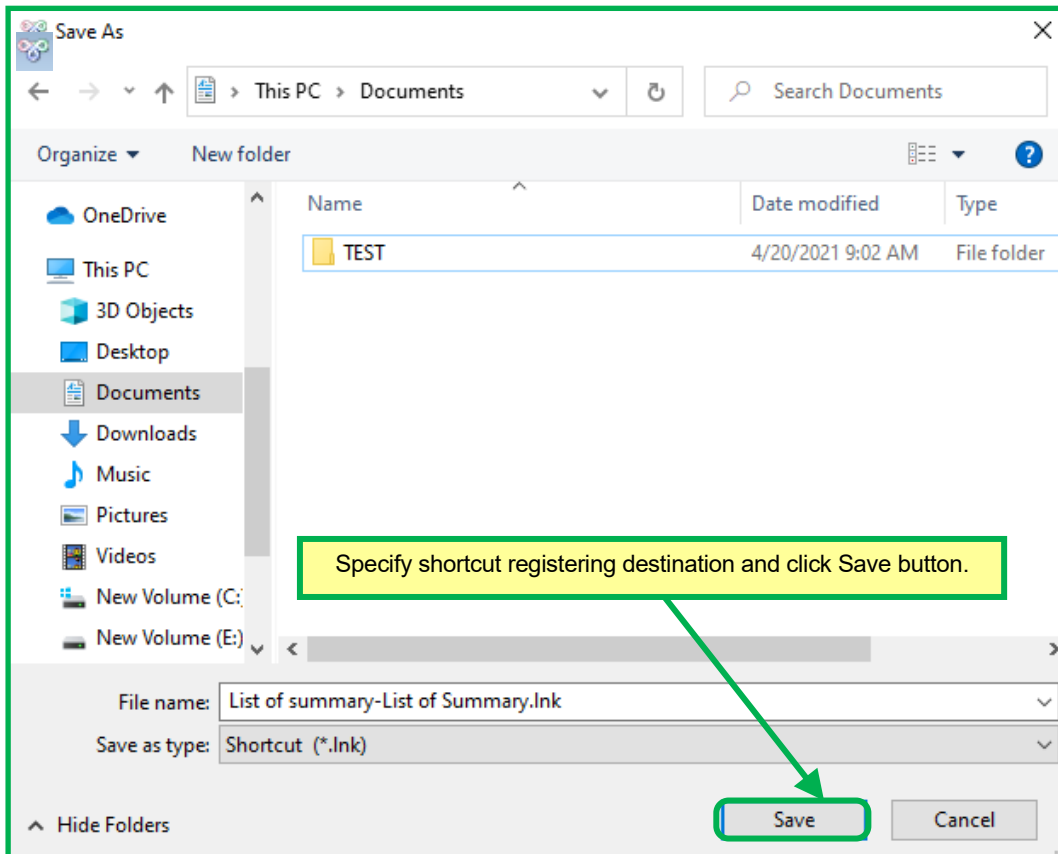
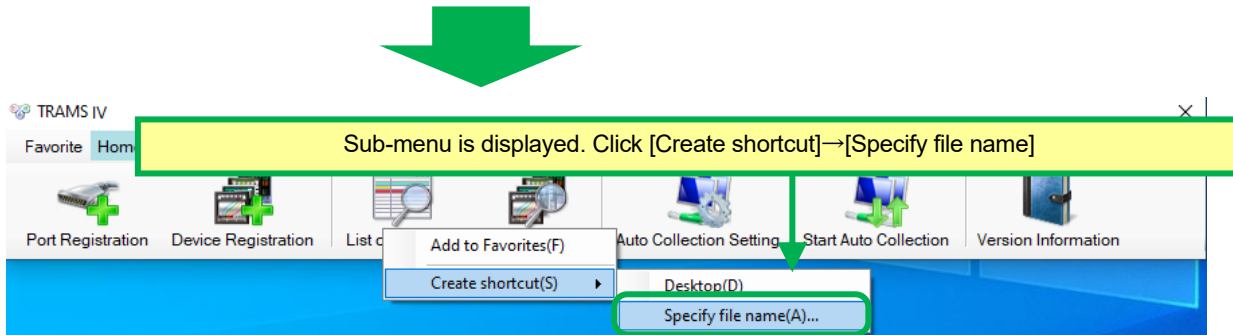
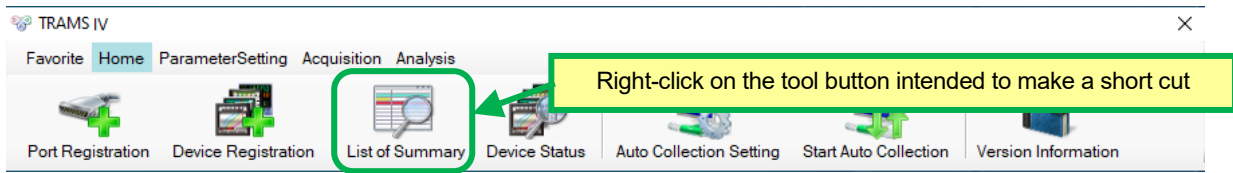

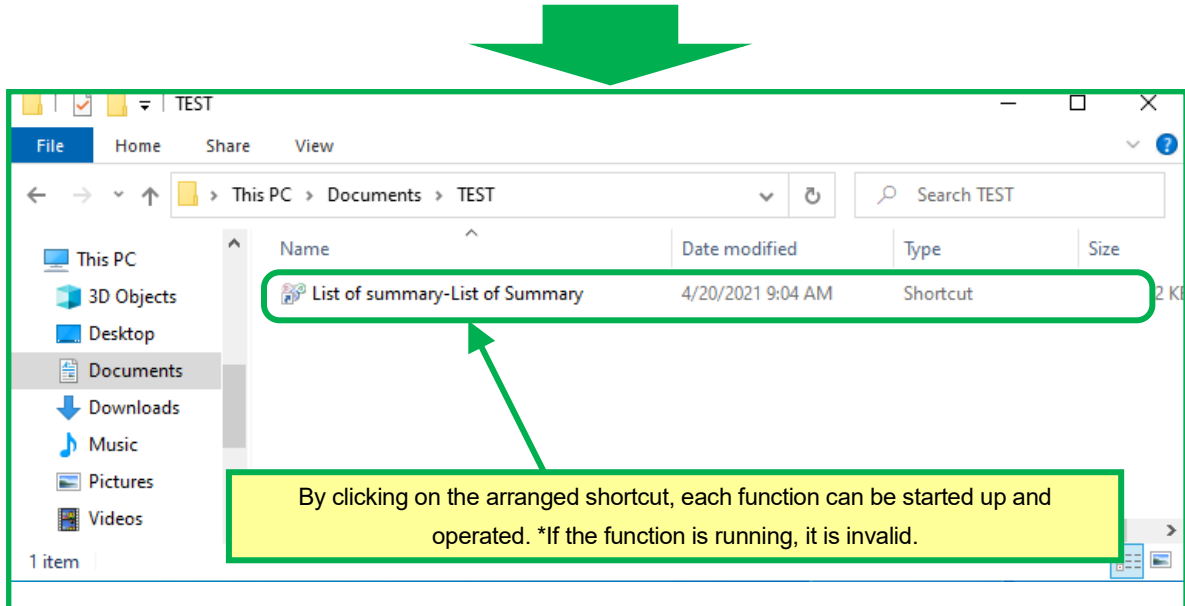

## 16 Troubleshooting

Phenomenon and their cause and their countermeasures are described below when an abnormality is found in the operation or function of TRAMS.

No.	Phenomena	Cause/ Countermeasure
1	The installation does not complete normally.	Check if there is enough hardware free space. (Refer to 1-8)
2	TRAMS does not start up	There is a possibility that the installation is not performed normally. Uninstall the software and install again to check if it can be startup normally.
3	It was working normally, but malfunction occurred suddenly.	End TRAMS and startup TRAMS. *If the software is terminated due to an accidental error, data backup of the unsaved data is not done, so set them again.

# CHINO

---

## CHINO CORPORATION

32-8, KUMANO-CHO, ITABASHI-KU, TOKYO 173-8632

Telephone: 81-3-3956-2171

Facsimile: 81-3-3956-0915

E-mail: [inter@chino.co.jp](mailto:inter@chino.co.jp)

Website: <https://www.chino.co.jp/>

---

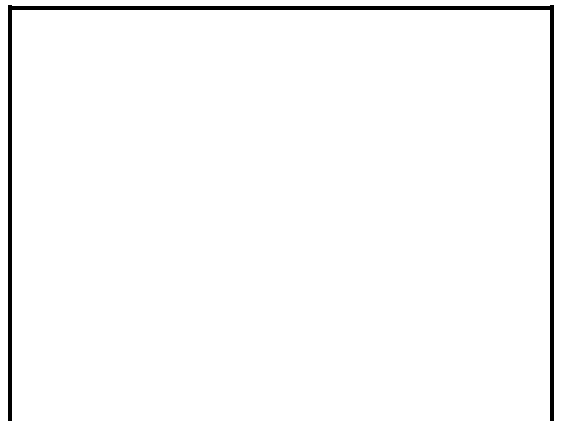

Printed in Japan